

Intellect Power Control Module

Use with Intellect Integrated Fixture Control System

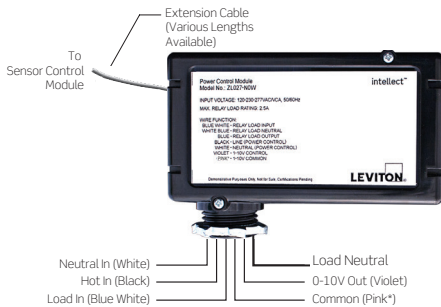

* Depending on manufacture date, pink wire may be gray

Description

The Leviton Intellect Power Control Module (PCM) is designed to be mounted directly into lighting fixtures and used as a power pack in an Intellect Integrated Fixture Control System. The PCM connects to the Intellect Sensor Control Module (SCM) via a short extension cable. Integrate with downlights, track fixtures and other general lighting to create an advanced intelligent lighting system that complies with energy codes.

The Leviton Integrated Fixture Control System is made up of three interchangeable components. A range of options are available to meet the specific needs of each lighting fixture type.

- **Sensor Control Module**—wirelessly communicates to all other Intellect devices within the room
- **Power Control Module**—receives commands from the Sensor Control Module and provides relay power control
- **Keypad Room Controller**—acts as the primary user interface and coordinates all the functions within the room; provides the Bluetooth® interface for connection to the Intellect App

App Configuration

Fixtures are wirelessly configured, monitored and controlled as part of the system they are connected to using that system's configuration app which operates on an Android or iOS device.

Applications

- 0-10V and power control of Intellect-enabled fixtures
- Interface to Intellect Sensor Control Module
- Wireless lighting control systems
- Create Intellect-enabled light fixtures
- Integrated, intelligent fixture controls
- Primary fixture types: switching only, or 0-10V control where a knockout power pack is desired

Leviton Manufacturing Co., Inc. Lighting & Controls

10385 SW Avery Street, Tualatin, OR 97062 tel 800-736-6682 tech line (6:00AM-4:00PM PT Mon-Fri) 800-959-6004

©2024 Leviton Manufacturing Co., Inc. All rights reserved. Subject to change without notice.

Features

- 120-277V, 50/60 Hz power input
- 3/4" nipple and locknut for installation into a standard 3/4" knockout
- All terminations on pigtails
- Emergency control—UL924 rated, monitors local normal power through the control input and ensures device is on upon normal power failure
- UL2043 Plenum rated
- 0-10V control and power relay rated for all common load types:
 - LED
 - Fluorescent
 - Tungsten
 - Resistive
 - Motor loads
- 3% accurate metrology
- Power supply output short circuit protection
- Optimal installation flexibility
- Monitored points:
 - kWh
 - kW
 - Voltage
 - kVARH
 - Power factor
 - kVAR
- Intellect products are listed on the DesignLights Consortium® (DLC) Qualified Product List (QPL) when used as part of a GreenMAX DRC System



Dimensions Diagram

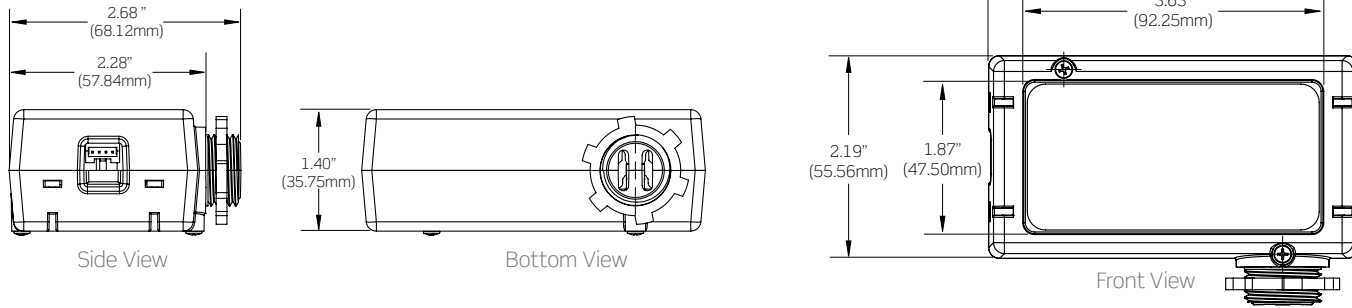

Specifications

Electrical	
Power Input	2.5A, 120-277VAC, 50/60 Hz
Output	4A: Ballast, electronic ballast, LED, Tungsten, resistive, general purpose Motors: 1/8HP at 120V, 1/16HP at 277V
Control	0-10V, 10mA Sinking, ANSI C82.11, Appendix E2
Power Monitoring	KWH, KW, Power Factor, Voltage, Current, KVAR, KVARH, 3% accuracy
Environmental	
Operating Temperature Range	32° to 167° F (0° to 75° C)
Storage Temperature Range	-4° to 185° F (-20° to 85° C)
Relative Humidity	0 to 90% non-condensing, for indoor use only
Other	
Intellect Energy Codes	Can be used to comply with IECC, ASHRAE 90.1 and 2019 Title 24, Part 6 dimming, occupancy/vacancy sensing and daylight harvesting requirements
Intellect System Listings	UL/cUL Listed, UL924, NOM Certified, RoHS 2 Compliant, and IEC61000-4-2, complies with IEEE 802.15.4, UL916 standard for energy management equipment, UL2043 for plenum rated, NEMA 410 compliant, listed on the DesignLights Consortium® (DLC) Qualified Product List (QPL) when used as part of a GreenMAX DRC System
Radio Certifications	FCC certified for wireless communication (U.S.), FCC ID: 2473A-PVDIM, IC Certified (Canada), IC ID: 2473A-PVDIM
Warranty	Limited 5-Year

Ordering Information

Intellect Power Control Module

Cat. No.	Description
ZL027-N0W	Intellect Power Control Module, 2.5A, 0-10V 10mA Sink Current. Nipple Mount. Bulk Packed, 25/carton.
ZLAEX-012	Extension Cable, for use between Intellect Sensor and Intellect Power Control Module, 12"
ZLAEX-018	Extension Cable, for use between Intellect Sensor and Intellect Power Control Module, 18"
ZLAEX-024	Extension Cable, for use between Intellect Sensor and Intellect Power Control Module, 24"
ZLAEX-030	Extension Cable, for use between Intellect Sensor and Intellect Power Control Module, 30"

Leviton Manufacturing Co., Inc. Lighting & Controls

10385 SW Avery Street, Tualatin, OR 97062 **tel** 800-736-6682 **tech line** (6:00AM-4:00PM PT Mon-Fri) 800-959-6004

Leviton Manufacturing Co., Inc. Global Headquarters

201 North Service Road, Melville, NY 11747-3138 **tel** 800-323-8920 **tech line** (8:00AM-10:00PM ET Mon-Fri, 9:00AM-7:00PM ET Sat, 9:00AM-5:00PM ET Sun) 800-824-3005

Visit our Website at: www.leviton.com/intellect

©2024 Leviton Manufacturing Co., Inc. All rights reserved. Subject to change without notice.

G-9607H/F24-mm
REV JUN 2024