

# GreenMAX®

## Users Manual



Built by the industry, for the industry.



# GreenMAX Users Manual

version 2.23

Date: Sept 18, 2011

If this equipment is being used as Emergency Lighting and Power Equipment, please adhere to the following information.

Apply the "Emergency Circuits" label, provided, to the front of the door

## IMPORTANT SAFEGUARDS

When using electrical equipment, basic safety precautions should always be followed including the following:

### a) READ AND FOLLOW ALL SAFETY INSTRUCTIONS

- b) Do not use outdoors.
- c) Do not mount near gas or electric heaters.
- d) Equipment should be mounted in locations and at heights where it will not readily be subjected to tampering by unauthorized personnel.
- e) The use of accessory equipment not recommended by manufacturer may cause an unsafe condition.
- f) Do not use this equipment for other than the intended use.

## SAVE THESE INSTRUCTIONS

All servicing shall be performed by qualified service personnel.

If any Emergency Circuits are fed or controlled from this panel, it must be located electrically where fed from a UPS, generator, or other guaranteed source of power during emergency and power outage situations.

## Table of Contents

<b>System Introduction.....</b>	<b>5</b>
Overview .....	6
Structure.....	7
Enclosure .....	8
Command Module.....	9
Relays .....	10
Relay Insert Panels .....	12
Handheld Display Unit.....	13
<b>Installation - Cabinets .....</b>	<b>15</b>
Enclosure Sizes .....	16
Plan Installation.....	17
Mounting and Installation .....	18
Door and Covers .....	19
<b>Wiring .....</b>	<b>21</b>
Low Voltage Wiring - Sensing Devices .....	22
Low Voltage Wiring - Switches.....	23
Emergency Input.....	24
<b>Network .....</b>	<b>25</b>
LumaCan Network .....	26
LumaCan Network Addresses .....	27
LumaCan Network Topology.....	28
<b>The Start-Up Process .....</b>	<b>29</b>
Overview .....	30
Preparation.....	31
Interconnect the Relay Cabinet - Step 1 .....	32
Interconnect the Relay Cabinet - Step 2 .....	33
Interconnect the Relay Cabinet - Step 3 .....	34
Interconnect the Relay Cabinet - Step 4 .....	35
Connect Digital Switches .....	36
LumaCan Check List.....	37
Firmware Upgrade - Step 1.....	38
Firmware Upgrade - Step 2.....	39
<b>Programming .....</b>	<b>41</b>
Programming Basics.....	43
<b>Frequently Asked Questions .....</b>	<b>47</b>
Frequently Asked Questions .....	48
Setting LumaCan Addresses .....	49
Data Cable Requirements.....	50
<b>Ratings .....</b>	<b>51</b>
Ratings.....	52



# Section 1

## System Introduction

### **Overview**

The GreenMAX Lighting Control System is a micro-processor based, programmable control relay system.

It utilizes LumaCan communication protocol over CAT6 data lines to communicate between control points in a distributed control scheme.

The GreenMAX system utilizes the advanced Leviton high performance relay module. These robust relays perform at levels previously unavailable in the lighting controls market. Flexible programming capability, daylight harvesting, zero-cross technology, and unmatched control power, create an energy management system of unparalleled performance.

This Manual outlines the installation and capabilities of the control system in network and standalone commercial applications.



**Structure**

The main components of the GreenMAX Lighting Control System are the:

- Enclosure
- Command Module
- Relays
- Relay Insert Panels
- Handheld Display Unit
- Digital Switches
- Remote Input Cabinet

Ancillary equipment:

- Occupancy Sensors
- Photocells
- Low Voltage Switches



### **Enclosure**

The base enclosures are rated NEMA 1. The enclosure is delivered to the jobsite empty without any of the electronics or relays installed.

The enclosure is divided into compartments corresponding to the voltage contained within.

- The Low Voltage area contains voltages of 24Vdc that are associated with the system controls.
- The Lighting and Circuit Wiring area contains voltages of 24 to 600Vac. These two areas are segregated and are accessible through separate covers. The cabinet door opens to provide access to the Low Voltage area only. The removal of the cabinet side and bottom covers is required to access the high voltage area. The areas in the upper left and right corners of the enclosures can be configured with the partitions provided, to be either Lighting and Power wire-way or Low Voltage.

Enclosures are available in four sizes to accommodate 8, 16, 32, or 48 relays. They also provide mounting areas for Command Modules with Low Voltage inputs in quantities of 8 or 16.

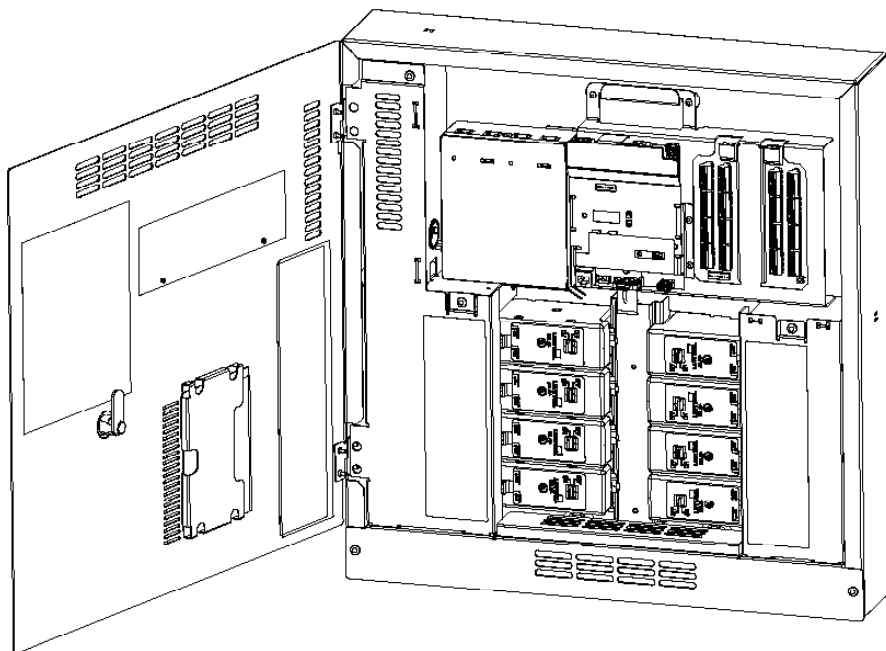

### Command Module

Each Command Module has three components:

1. Power Supply

The Power Supply is a 70W +24Vdc power supply. It can be connected to a single phase circuit up to 277Vac. Wire leads are provided for this purpose. The Power Supply provides all necessary power for the cabinet it is mounted in as well as the ancillary devices. All output connections are made with RJ45 connectors.

2. Main Processor Unit

The Main Processor provides the systems intelligence and memory. It manages all communications between the LumaCan, Ethernet, and the relay communication bus. The Emergency input signal is terminated at the terminal block provided.

3. Low Voltage Input card

This card provides all the connection points for low voltage inputs like occupancy sensors, photocells, low voltage switches, and contact closures. All these devices must be +24Vdc devices. A terminal block is provided for connecting wires to the input points on the board. The low voltage input cards are available with either 8 or 16 input points. The input signals must range between 0 and +10Vdc (analog) or be two states of either 0 or +24Vdc (binary).

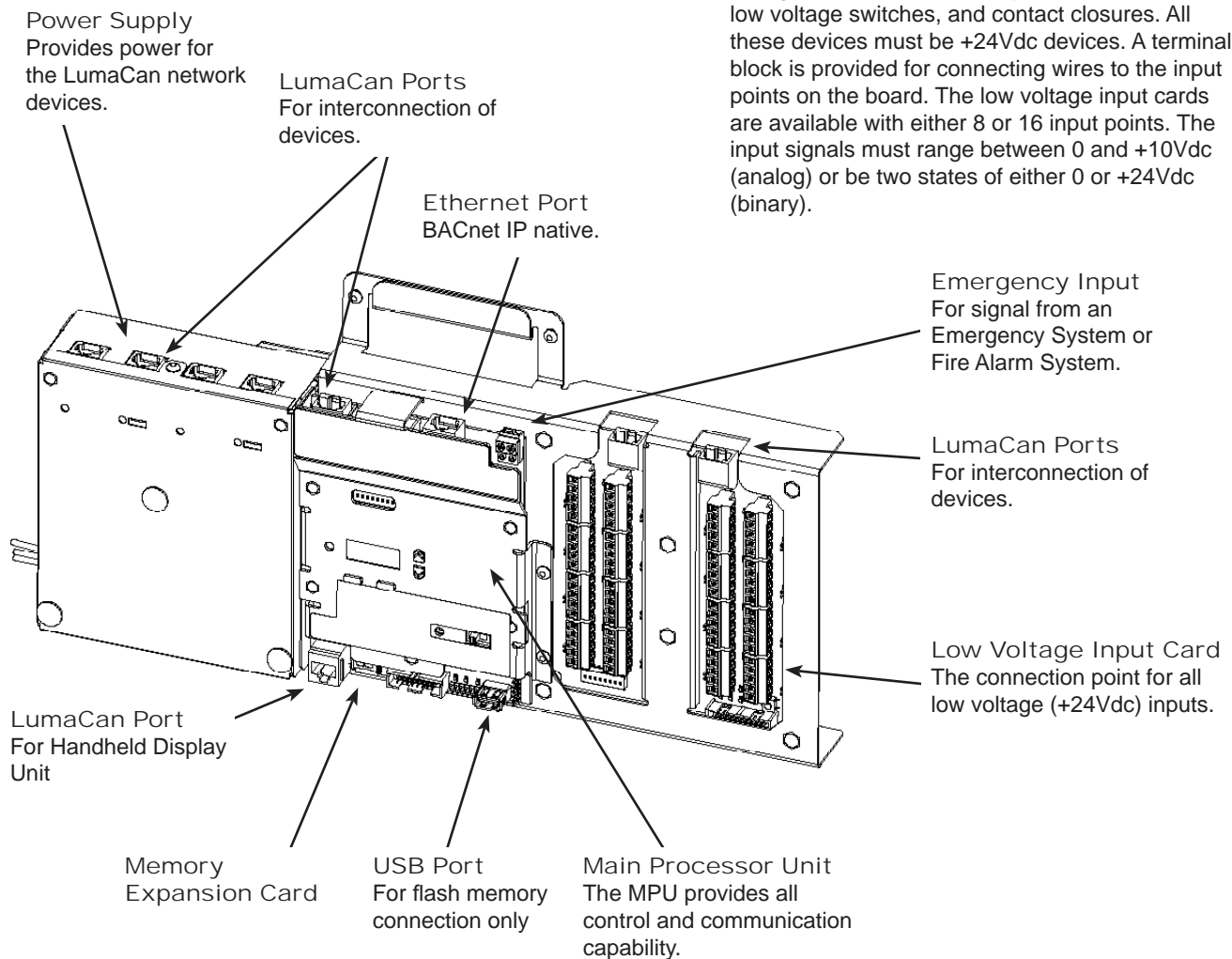

### Relays

The GreenMAX Relays are available in the following configurations:

- Single Pole Latching Basic
- Single Pole Return to Closed Latching Basic
- Single Pole Dimming 0-10Vdc
- Double Pole Latching Basic
- Double Pole Return to Closed Latching Basic

All of these relay types have the same dimensions and may be installed anywhere in the cabinet. Any combination or configuration of relay types can be accomplished with the standard cabinet.

The ratings for these relays are listed in the Ratings section of this manual.

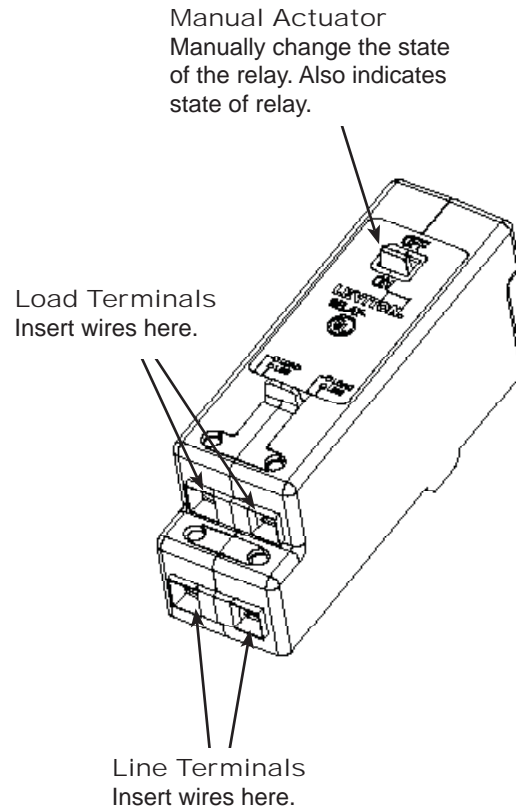

### Relays

The GreenMAX Relays are “smart” relays that provide two way communication with the cabinet processor via the distribution spine of the Relay Insert Panel. Every relay can be programmed to operate with any control device connected to the system regardless of location. The relays utilize zero-cross technology to extend relay life.

Manual activation of the relay is provided by an external handle on the relay. This is a direct mechanical link to the contact set of the relay. The relay can be actuated at any time even when the Command Module is not energized.

The Dimming and Sensing Relay provides dimming control for 0-10Vdc syncing ballast or LED driver circuits. The relay provides control power to the ballast with a single pole relay contact. The dimming control is provided by the designated signal terminals on the relay module. This relay module is the exact physical size as the regular relays and can be used in any combination.

The terminals of the relays are suitable for copper wire sizes of #14 awg through # 8 awg. All wire should be twisted together before insertion into the terminals.

The insulation of the conductor should be rated for a minimum of 600Vac and 75°C.

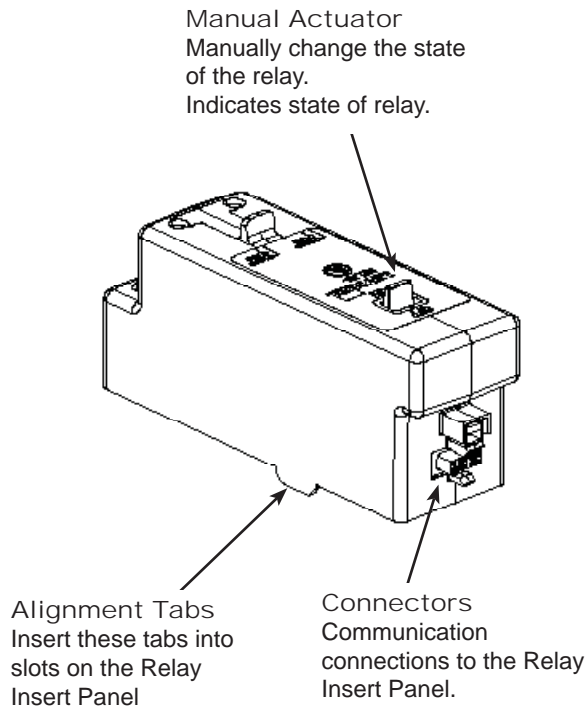

Manual Actuator  
Manually change the state of the relay.  
Indicates state of relay.

Alignment Tabs  
Insert these tabs into slots on the Relay Insert Panel

Connectors  
Communication connections to the Relay Insert Panel.

## System Introduction

### Relay Insert Panels

The individual GreenMAX Relays connect to Relay Insert Panels that fasten into the enclosure with two screws and are supported on two mounting tabs. The tabs on the inside of the relay cabinet align with the notches on the bottom edge of the Relay Insert Panel. Tip Panel in and fasten in place with screws provided.

No tools are required to remove or install the relays. The relays snap into place on the Relay Insert Panel. The distribution spine of the Relay Insert Panel plugs into the next component above it. This may be a Command Module or another Relay Insert Panel.

NOTE: A blank filler module is required in any space not occupied by a relay.

Relay Insert Panels contain quantities of 8 or 16 relays each. The chart outlines the quantity of Relay Insert Panel required by each size of enclosure.

Enclosure Size	Relay Insert Panels	
	Qty Required	Relay Count
8	1	8
16	1	16
32	2	16
48	3	16

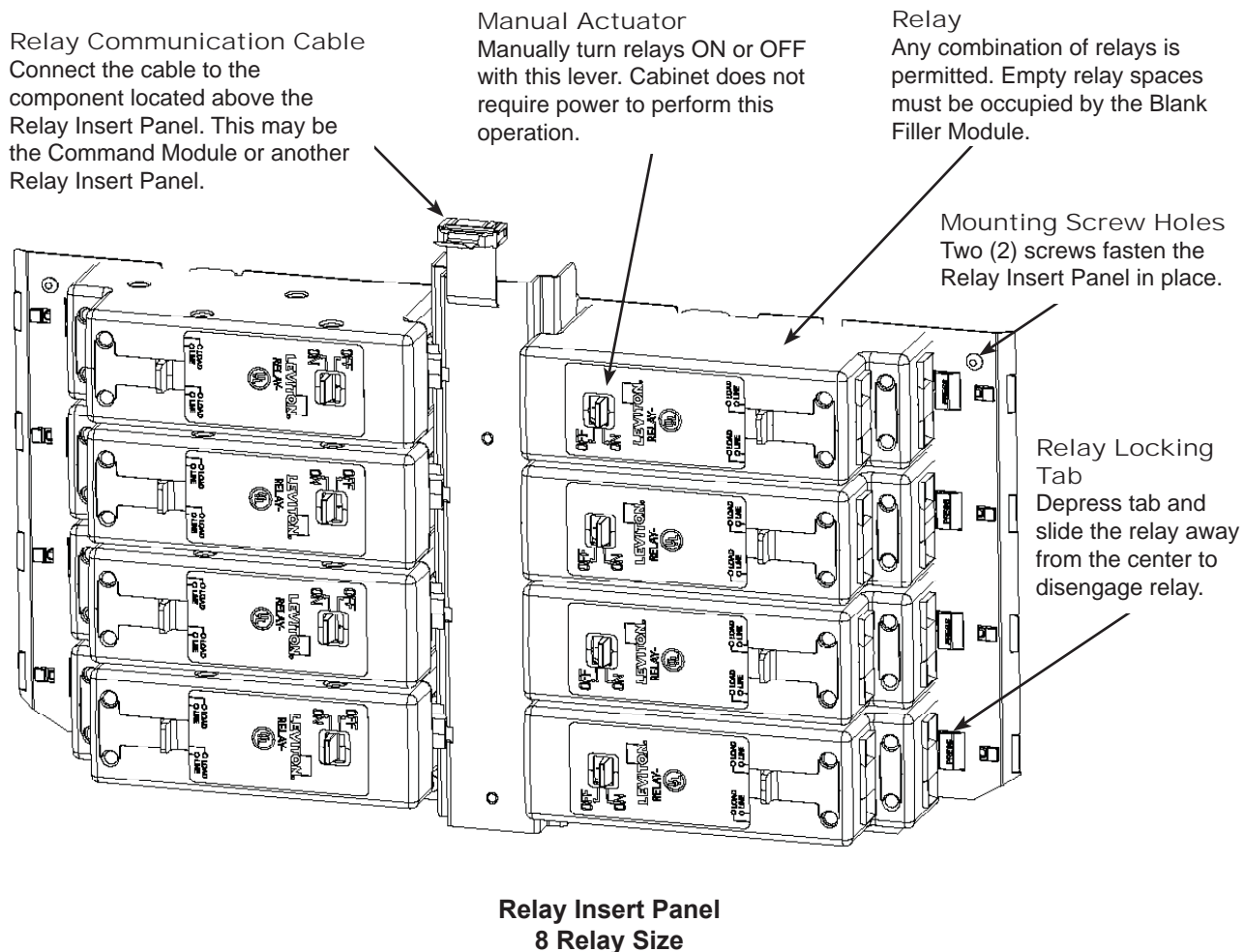

## **Handheld Display Unit**

The GreenMAX Handheld Display Unit provides the following levels of functionality:

- **Monitoring**

The overall system operation can be monitored from a connected Handheld Display Unit (HDU). The system clock is displayed on the HDU as well as sunset and sunrise times. Alarm conditions and acknowledgements are communicated at this level.
- **Control**

The Handheld Display Unit (HDU) provides an interface with the system intelligence and the scheduling details. The user can create and modify real time scheduling agendas and calendars.
- **Configuration**

This area of Handheld Display Unit (HDU) provides access to the building blocks required to set up and configure the system.

The GreenMAX system will continue to operate without a HDU plugged in to the system. The system schedule is a function of the complete system and not the HDU. The HDU provides real time access to all information available in the system.

Access to the Handheld Display Unit and the various control levels are password protected. The end user can create and save their own secure passwords.

The portability of the HDU maximizes efficiency during system start-up and commissioning. The HDU can plug into any available LumaCan port and provide complete control and configuration capability from that location. A LumaCan access port is available on each GreenMAX Digital Switch, Command Module, and Remote Input Cabinet.

### **Handheld Display Unit: Batteries**

The HDU comes complete with 4 rechargeable 'AA' batteries. The batteries charge when the HDU is connected to the LumaCan network. The unit has a typical battery life of 8 hours after a complete charge.





## Section 2 Installation - Cabinets

## Installation - Cabinets

### Enclosure Sizes

The GreenMAX Relay System is available in standard sizes that contain space for 8, 16, 32, and 48 relays.

The enclosures are delivered to the jobsite empty of any relays or electronics.

The physical dimensions of the enclosures are listed in the size chart below.

### Dimensions

Cabinet Size	Width	Height	Depth
8	21"	22"	4"
16	25"	32"	4"
32	25"	48"	4"
48	25"	64"	4"

8 Relay

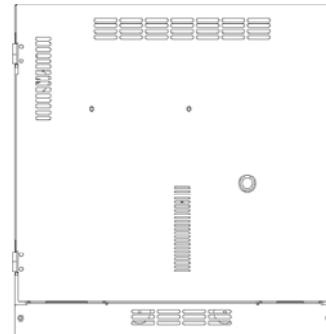

48 Relay

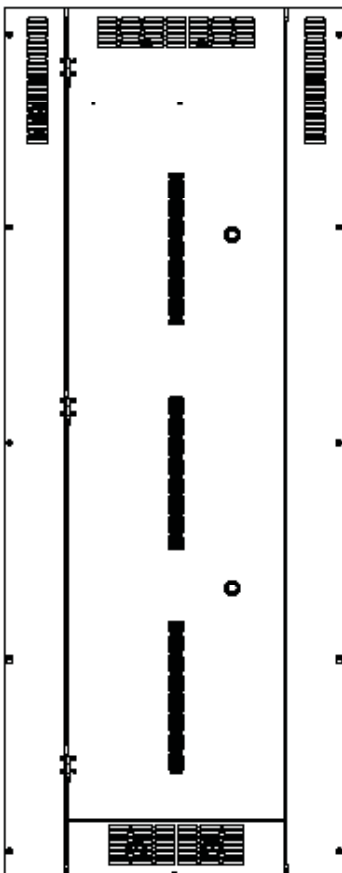

32 Relay

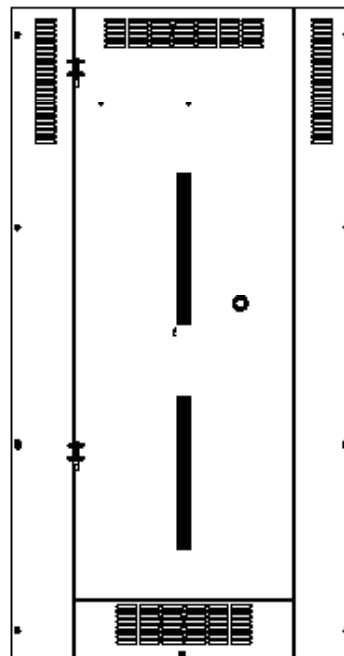

16 Relay

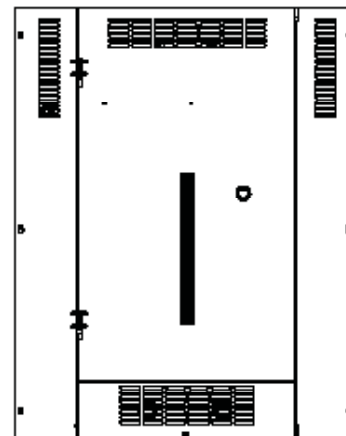

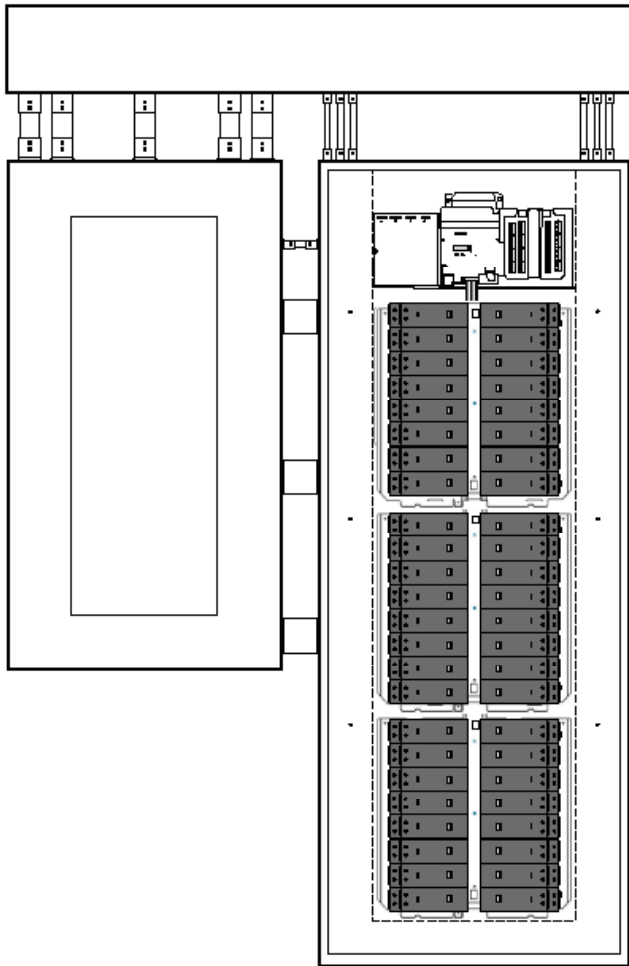

### ***Plan Installation***

It is best to mount the GreenMAX relay cabinet in an area convenient for maintenance and monitoring. It should be mounted in combination with a branch circuit panel-board or distribution panel.

Plan the layout of the installation in advance and provide adequate space for entry of conduit according to the needs of the project.

Consideration should be given for routing of circuit conductors in and out of the cabinet in the most efficient manner possible.

Locate cabinet to maintain an ambient operating temperature of 32°F to 104°F (0°C to 40°C) or 68°F to 86°F (20°C to 30°C) if used as Emergency Lighting Power Equipment.

Locations should be indoors, free of vibration, stable, dry, non-corrosive and with non-condensing humidity of less than 90%.

The GreenMAX cabinet is designed for surface mount applications only.

### Mounting and Installation

Securely mount enclosure to wall using fasteners appropriate for wall type. Mounting holes are provided in the enclosure, the upper holes are keyhole slots to facilitate easy hanging. Any field drilled mounting holes should be confined to the wire-way areas so that they do not obstruct the installation of the Relay Insert Panels or the Command Module.

Install all conduit runs and pull all lighting circuit and power wiring. It is recommended that all wire be pulled prior to installing the Command Module and Relay Insert Panels. This will prevent damage to the electrical components.

Multi-use areas.  
Removable barriers partition these areas (both sides) to meet field requirements.

Mounting holes.  
Quantity of holes provided depends on length of cabinet. Upper holes are slotted to ease installation. Additional holes may be added in the wire-way area only. Avoid areas reserved for the Relay Insert Panels and the Command Module.

Conduit Entry.  
Conduits can enter the cabinet on all four (4) sides. Plan for Low Voltage conductors at the top of the enclosure.

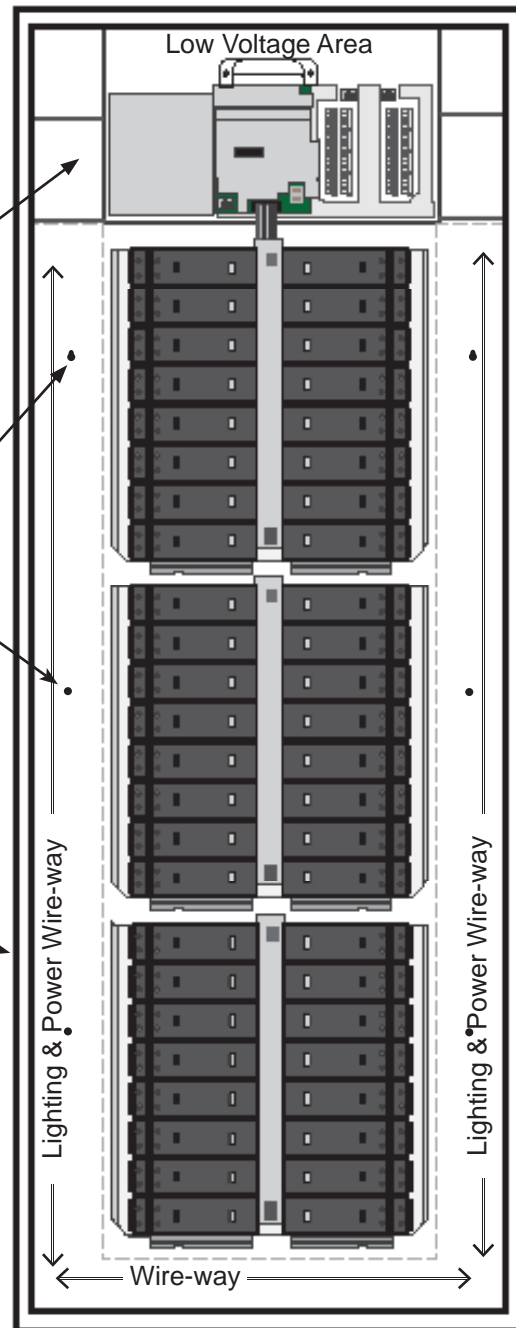

48 Relay Cabinet

### Door and Covers

The GreenMAX relay cabinet door and cover system is designed to provide limited access to the interior components. A locking door covers the low voltage area in the cabinet. The door can be removed from the cabinet only when it is swung open and lifted off the hinges.

The wiring and lighting circuit wiring areas are concealed behind the panel covers. These covers are designed to be fastened in place with screws after final assembly.

During construction phases easy access to the wiring compartment is provided by the quick install features of the three part covers. The left and right covers are each held in place by a key-hole slot in the cover plate that slides over a single screw and a hook and tab feature at the top of the cover.

The cabinet ventilation is provided through the slots in the door and covers. Keep these areas free of obstructions to maximize the free flow of air through the cabinet. No fans are required for cooling.

The door cannot be removed from the hinges when the door is closed and locked. The latching arm of the lock fits into a slot in the covers and is concealed by the door. Features in the hinges also prevent removal of the door.

The inside of the door is labeled with the relay ratings, panel model number, and cabinet wiring diagram. There is also a document holder for installation instructions and relay layout schedule. The Handheld Display Unit mounts to the support pins on the inside of the cabinet.

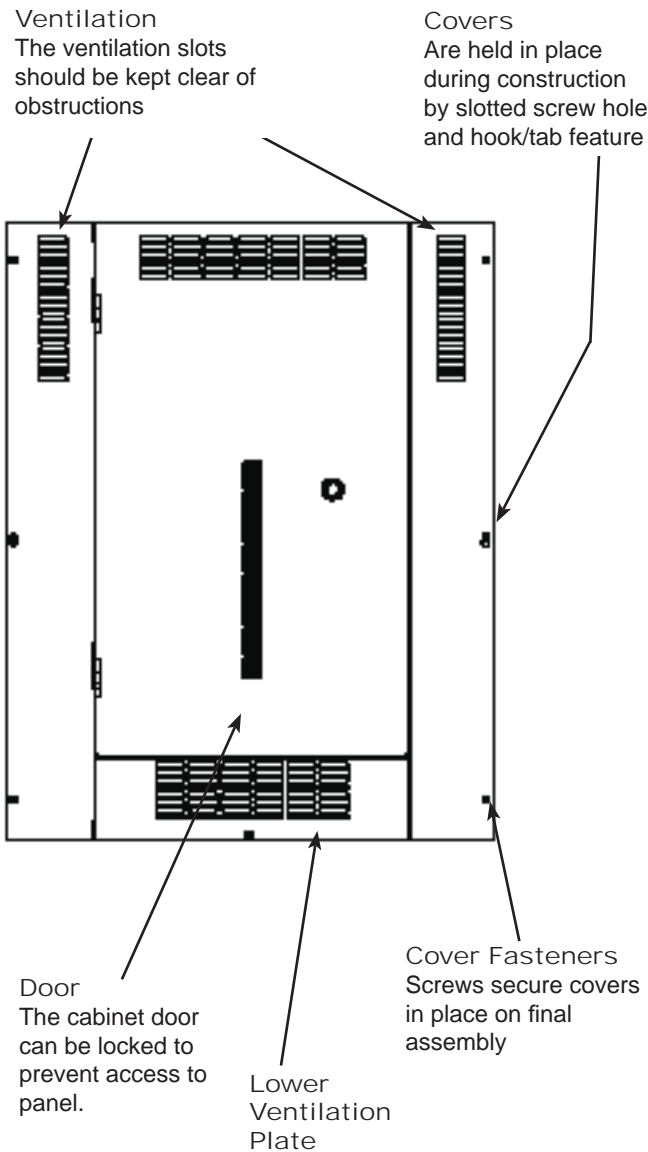

- Door & Cover Removal**
1. Unlock and open door.
  2. Lift door off hinges.
  3. Remove lower ventilation plate
  4. Remove left and right covers.

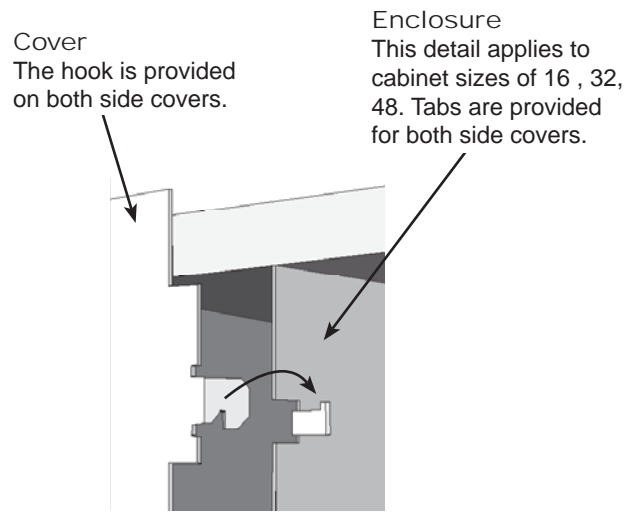

**Cover Hook and Tab Detail**



## Section 3 Wiring

### Low Voltage Wiring - Sensing Devices

Input wiring from ancillary devices are terminated on the Low Voltage Input Card of the Command Module or Remote Input Cabinet. The card is mounted on the right side of the module.

The input terminal blocks on the Low Voltage Input Card are grouped into sets of 5 terminals. These green blocks may be removed from the Input Card by pulling straight out away from the unit. This will make terminating the individual wires easier. Take note of the terminal designations indicated on the drawing on the inside of the cabinet door, the markings on the circuit board, and on the green block itself to avoid mis-wiring. A 1/8" straight blade or a #1 Phillips screwdriver can be used to tighten the terminals. Make sure that the wires are not loose.

The terminal blocks provide the +24Vdc power to the attached devices. The power to the terminal block will not be available until the input has been configured by the user. This will take place during the configuration and commissioning phase of the installation.

The input blocks are organized in rows of four with the top terminals in the rows numbered 1, 5, 9, and 13.

Mis-wiring one of the terminal blocks will result in the +24VDC turning off until the problem is corrected. This affects only the incorrect input block and no other termination points on the card. There are no fuses involved in this method of protection. When the wiring is corrected, the power will return.

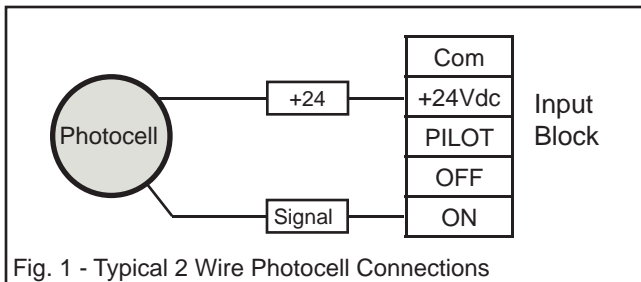
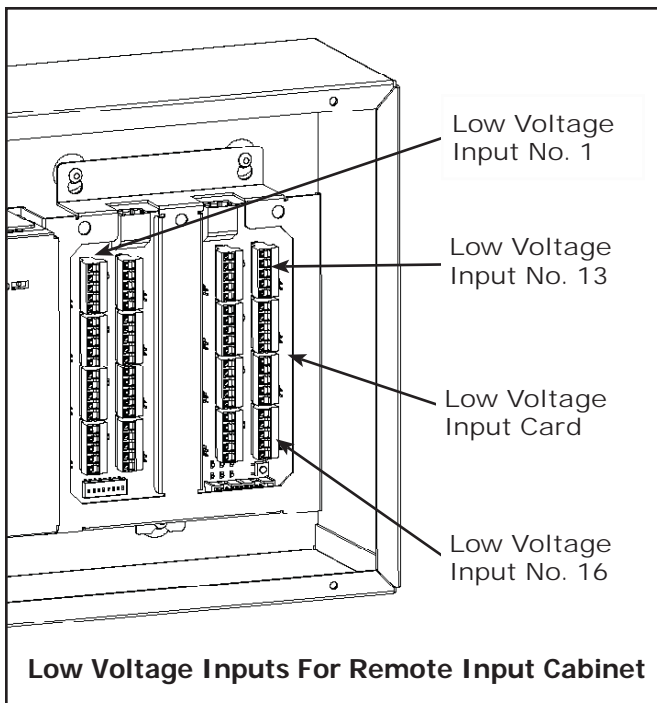

Fig. 1 - Typical 2 Wire Photocell Connections

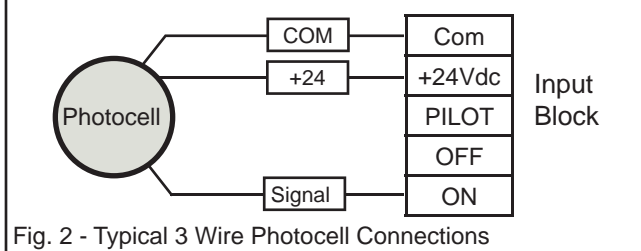

Fig. 2 - Typical 3 Wire Photocell Connections

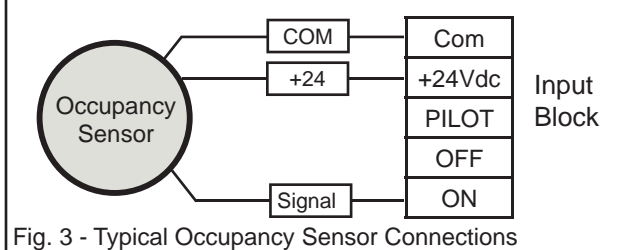

Fig. 3 - Typical Occupancy Sensor Connections

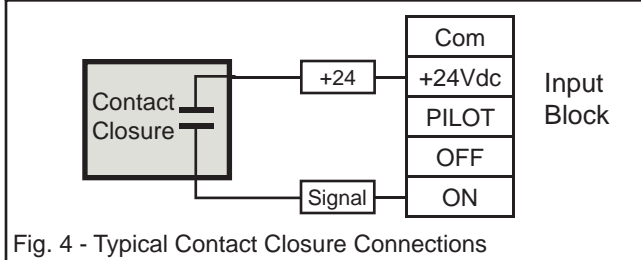

Fig. 4 - Typical Contact Closure Connections



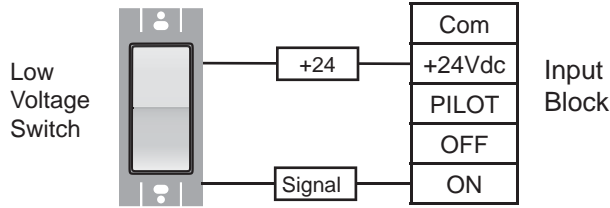

Fig. 5 - Typical Low Voltage Switch Connections

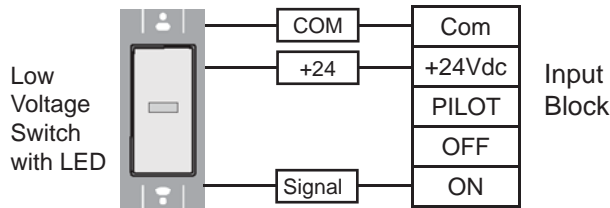

Fig. 6 - LV Switch 1 Btn Connections

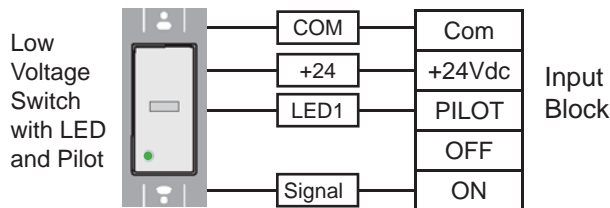

Fig. 7 - Typical LV Switch 1 Btn with Locator Connections

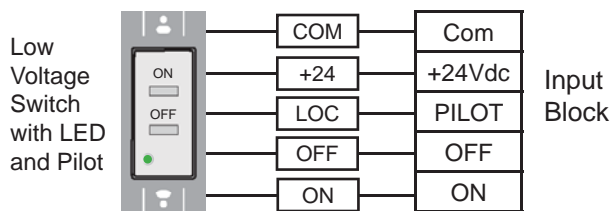

Fig. 8 - Typical LV Switch 2 Btn ON/OFF w. Locator Connections

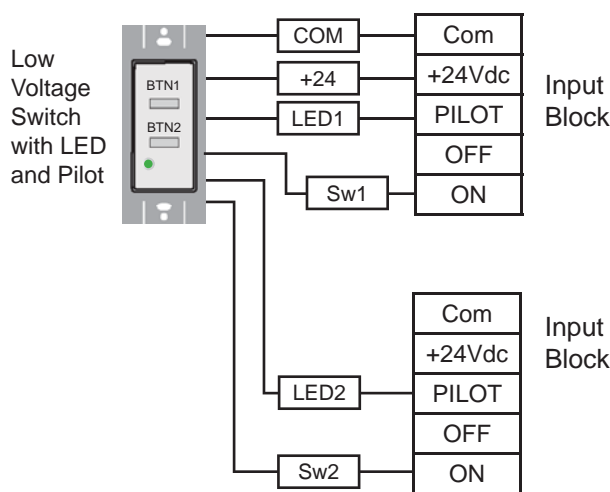

Fig. 9 - Typical LV Switch 2 Btn with Locator Connections

### Low Voltage Wiring - Switches

The GreenMAX system is compatible with a wide variety of Low Voltage Switches. All Leviton Low Voltages Switches from the Z-Max product line are directly compatible with the system. All switches operating at +24Vdc are compatible with the system as well.

The wiring diagrams on this page detail the typical wiring connections at the low voltage card of the Command Module as well as the Remote Input Cabinet. There may be other configurations depending on what type of switch is being used.

The input terminal blocks on the Low Voltage Input Card are grouped into sets of 5 terminals. These green blocks may be removed from the Input Card by pulling straight out away from the unit. This will make terminating the individual wires easier. Take note of the terminal designations indicated on the drawing on the inside of the cabinet door, the markings on the circuit board, and on the green block itself to avoid mis-wiring. A 1/8" straight blade or a #1 Phillips screwdriver can be used to tighten the terminals. Make sure that the wires are not loose.

The terminal blocks provide the +24Vdc power to the attached switch. Consult the wiring diagram supplied with the switch for specific device wiring requirements.

The power to the terminal block will not be available until the input has been configured by the user. This will take place during the configuration and commissioning phase of the installation.

The input blocks are organized in rows of four with the top terminals in the rows numbered 1, 5, 9, and 13.

Mis-wiring one of the terminal blocks will result in the +24VDC turning off until the problem is corrected. This affects only the incorrect input block and no other termination points on the card. There are no fuses involved in this method of protection. When the wiring is corrected, the power will return.

### Emergency Input

The wiring terminal block for the Emergency Input is located at the top of the Command Module. The terminal block is green in color and has two termination points. The Command Module provides +24 Vdc power to the circuit.

The Emergency Input circuit should be connected in series with a maintained contact closure that indicates the status of the building Emergency System or Fire Alarm System. The contacts should be Normally Open (NO) and close upon change of power source.

The response of the relays to the Emergency Input must be configured. The available relay response types are; ON, OFF, and Ignore. The default configuration setting is Ignore. Relay responses are configured during programming setup.

The Emergency Input signal will override all functionality of the system and force relays to their configured response state. Relays will return to their previous state after input signal is removed.

The Emergency Input signal only effects the relay cabinet it is connected to.

Maintained Contacts  
Closed when Emergency lighting  
is required.

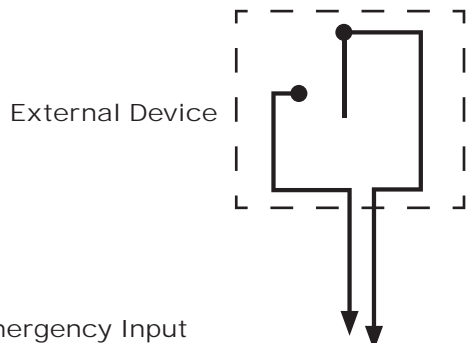

Emergency Input  
Terminal block  
may be removed to  
facilitate wiring

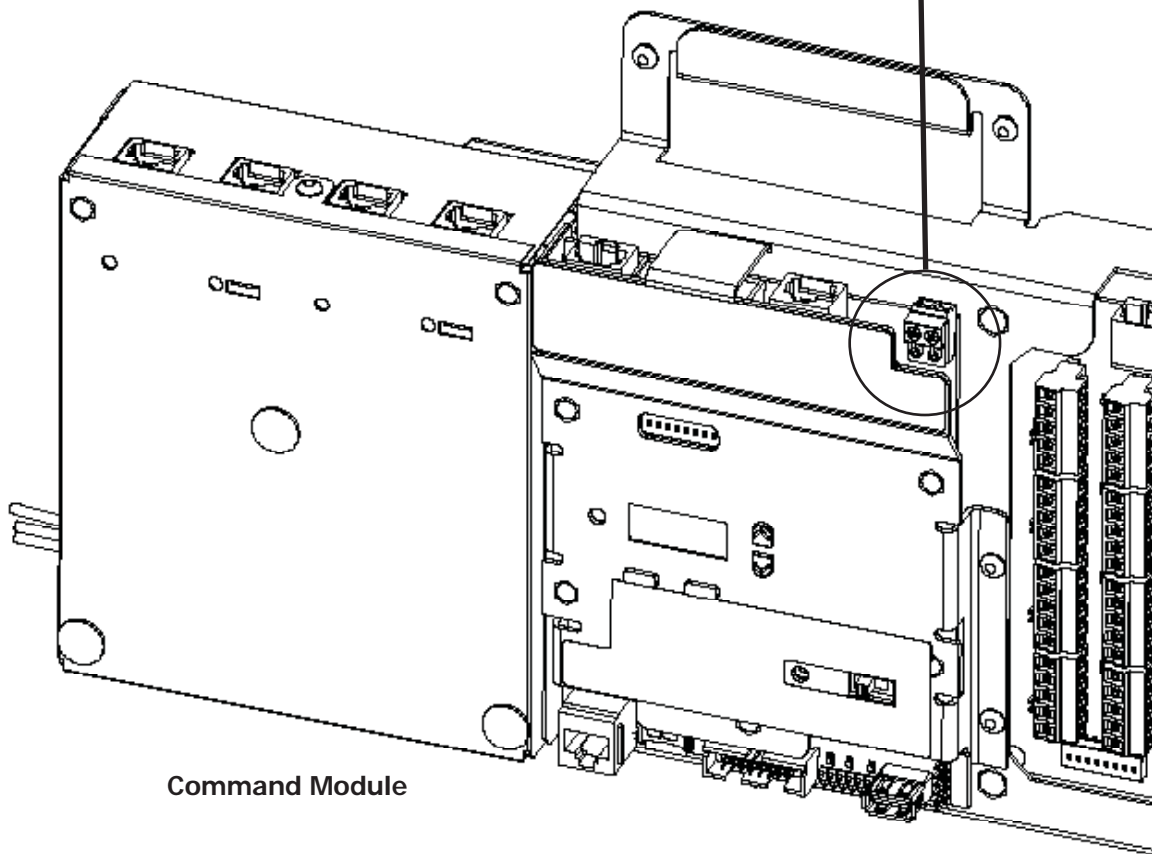
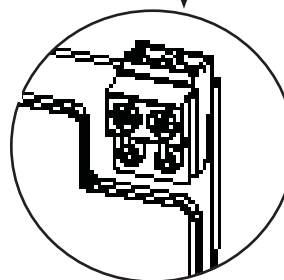

## Section 4 Network

### LumaCan Network

The communication network used by GreenMAX is a proprietary protocol running on CAT6 network cable. The network is connected together using RJ45 connectors. Factory assembled cables or field terminated cables can be used. All connections made in the field must be tested prior to interconnecting components. Test the cables with a CAT6 cable tester that identifies the wire pairs, their orientation, and placement.

All power supplies, processors, low voltage input cards, and digital switches are interconnected via CAT6 cable and RJ45 connectors. Power is provided by the power supply and delivered over the LumaCan network.

The maximum length of a continuous LumaCan network run is 1600 feet. End of run terminations must be set at the two ends of the network. A termination slide switch is provided on the back of each digital switch for this purpose. A jumper on two (2) terminal posts for termination is provided on every Main Processor board and on each Low Voltage Input Card.

Care must be taken to ensure that two (2) terminations jumpers or slide switches are set on the network. Two (2) end of run terminations provide optimum network performance, any other quantity degrades performance.

The LumaCan network must be daisy chained and "home runs" from devices must be prevented. LumaCan devices can reside on the network in any order as long as the daisy chain configuration is maintained.

A yellow LED is provided on each LumaCan device to indicate network "heartbeat." The flashing pattern of the LED can be used to diagnose health of the network.

Do not run LumaCan cables adjacent to or in close proximity to high voltage connectors.

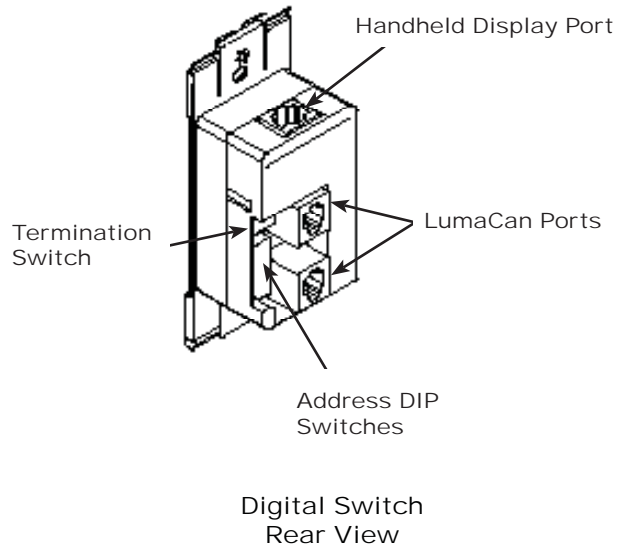

LumaCan Connectors  
LumaCan network connectors on all components are green in color.

MPU Heartbeat  
A yellow LED is provided on each MPU to indicate proper processor "heartbeat."

LumaCan termination  
A termination jumper is provided adjacent to the Handheld Display Unit port.

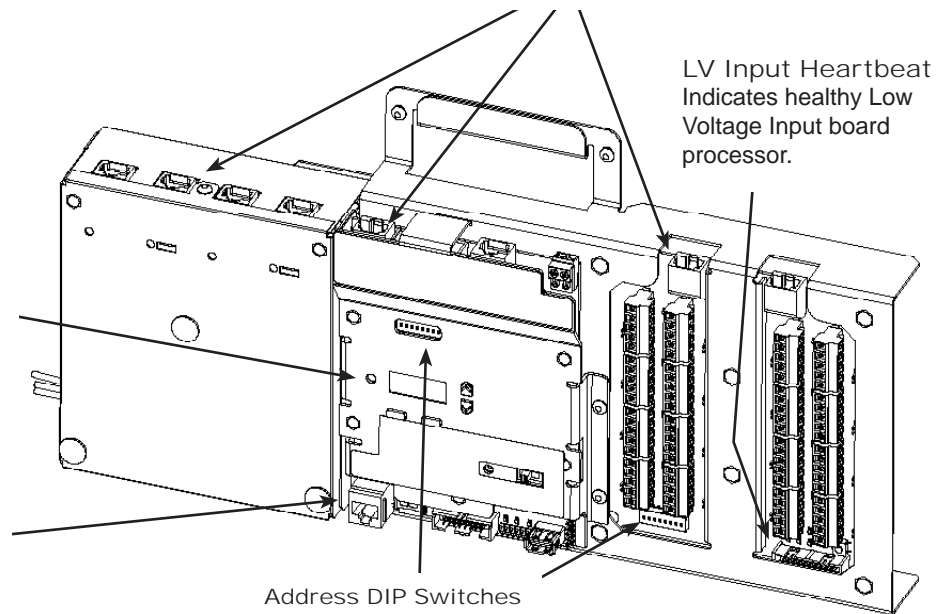

### LumaCan Network Addresses

The maximum number of LumaCan addresses on a network is limited to 250 unique addresses starting with ID 1.

There are dip switches that must be set to provide each device with an address. The device address is calculated by adding the values of the switches set in the ON position.

Each Main Processor board and Low Voltage Input require unique addresses and account for a total of two address when mounted together in a Command Module. The number of addresses required per device is listed in the table below.

Device	Address Quantity Required
Command Module without LV Input Card	1
Command Module with LV Input Card	2
Digital Switches 1, 2, 4 Button	1
Remote Input Cabinet	1

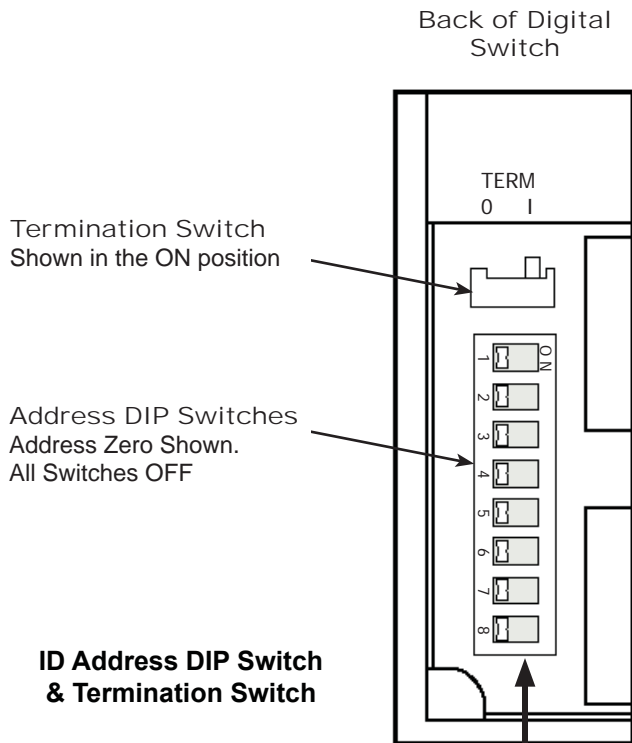

ID Address Value = Sum of Switch Values  
 ID 86 = 2+4+16+64

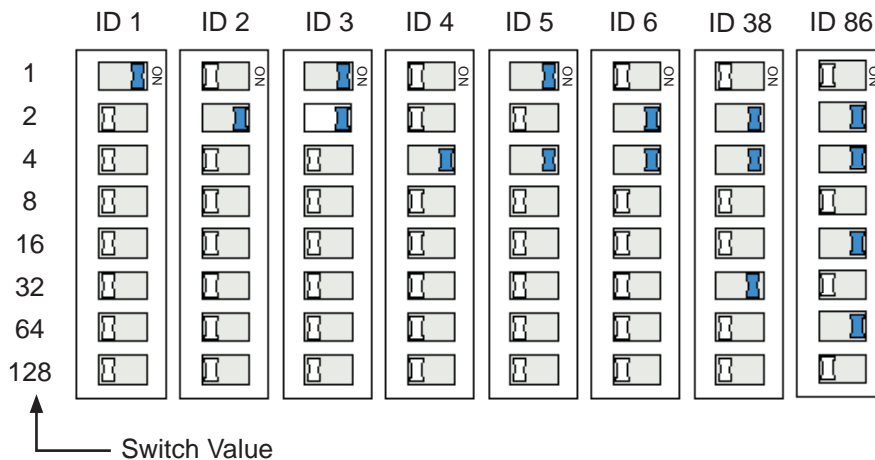

### LumaCan Network Topology

The GreenMAX power supply on the Command Module provides operating power to all digital switches on the LumaCan network up to the limits of the power supply. The power supply provides four (4) ports to connect devices and network segments. Two (2) of these ports provide continuous power and should be used to interconnect to the Main Processor board and the Low Voltage input card. The other two ports on the power supply have a slide switch provided to turn power ON or OFF to the segment of the network connected to it. An illuminated green LED indicates that there is power at the port. If the switch is turned OFF and the LumaCan cable is unplugged, the LED will be dark or OFF. If the LED illuminates after the network cable is plugged in, this indicates that power from another source is available on the cable. The switch disconnects the power supply from the network cable. If the LED remains dark or OFF when cable is plugged in, this indicates that no power is present on the cable.

The LumaCan network must be daisy chained and “home runs” from devices must be prevented. LumaCan devices can reside on the network in any order as long as the daisy chain configuration is maintained.

LumaCan network connectors on all components are green in color.

A yellow LED is provided on each LumaCan device to indicate network “heartbeat.” The flashing pattern of the LED can be used to diagnose health of the network.

Type A - Digital switches are powered from the relay cabinet. Termination switch is set to ON in digital switch ID 5 and termination jumper is on at the Command Module, all other termination switches are in the OFF position.

Type B - Digital switches are powered from ONLY ONE of the relay cabinets. Termination jumper is set to ON in both of the Command Modules, all other termination switches are in the OFF position.

Type C - Digital switches ID 3 & 4 are powered from relay cabinet ID 1 & 2. Digital switch ID 5 is powered from Relay Cabinet ID 6 & 7. Termination switch is set to ON for digital switch ID 5 and on the Command Module of relay cabinet ID 1 & 2. All other termination switches are in the OFF position.

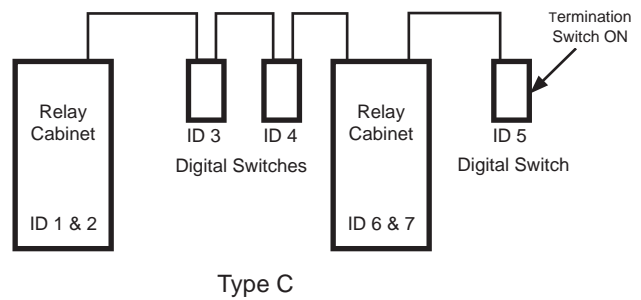
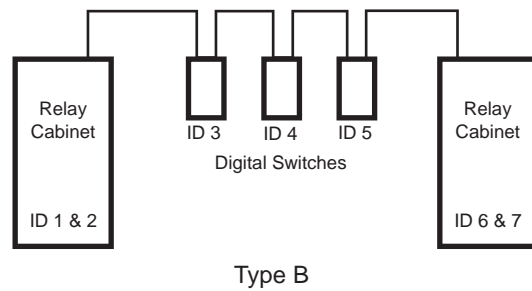
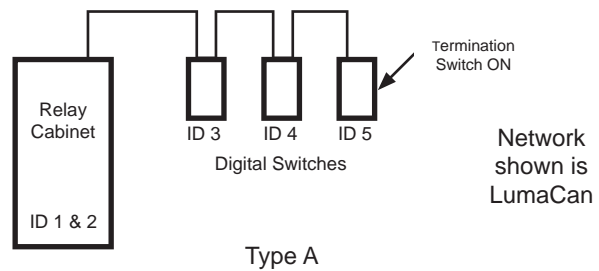

## Section 5 The Start-Up Process

### Overview

The GreenMAX system must be assembled and commissioned prior to full operation. Follow these general guidelines to perform this operation.

1. Preparation
  - Plan addresses
  - Acquire firmware upgrade
2. Build LumaCan network
  - Test cables
  - Interconnect Relay Cabinets
  - Connect Digital Switches
  - Set termination jumpers (2 required)
  - Configure power distribution
3. Firmware Upgrade
4. Configure all Low Voltage Input Cards
5. Build Groups (if required)
6. Create Schedules
  - Daily Agendas
  - Exception Calendars
7. Build Areas
  - Assign Schedule to Area
  - Add; Relays, Switch Buttons, Occupancy Sensors, Photocells
  - Assign Relays to; Switch Buttons, Occupancy Sensors, Photocells



### *Preparation*

1. Assemble all documentation including but not limited to; submittal drawings, single line diagrams, relay and circuit schedules, as built drawings, agenda worksheets.
2. Required equipment; CAT6/RJ45 cable tester, voltmeter, #2 Phillips screw-driver, Handheld Display Unit, control screw-driver (1/8" slotted or Phillips), 8-position modular plug breakout adaptor.
3. Visually inspect all wiring and compare to the submittal drawings. Take note of the position of any Emergency circuits, voltage barriers, separation of voltages, and routing of conductors. Work with the electrician to correct any discrepancies or errors.
4. Contact Leviton Technical Support for latest firmware version and load it on a USB thumbdrive memory stick.
5. CAUTION: Do not work on energized lighting circuits. Appropriate personal protective equipment should be worn when the covers are removed and cabinets are energized.
6. CAUTION: The manual actuators on the relays are not to be used as Lock Out or Tag Out locations. This should only be done at the circuit disconnecting means such as the circuit breaker or the disconnect.

### ***Interconnect the Relay Cabinet - Step 1***

The GreenMAX system must be commissioned prior to full operation. Follow these general guidelines to perform this operation.

1. Test all LumaCan Cables that have been field terminated. The termination configuration and wire pattern must be consistent throughout the system. Replace any broken or incorrectly wired connectors.
2. Start to interconnect the system at a relay cabinet. The connections in the cabinet are indicated on the label inside the cabinet door.
3. Check the wiring connections for the circuit that feeds the Power Supply of the Command Module. Tight connections should be made to a single-phase conductor, neutral, and ground. The equipment grounding conductor should be connected to the grounding point of the cabinet.
4. The neutral wire from the Relay Insert Panel should be connected to the neutral wire of the Power Supply if the circuit originates from the same source as the lighting circuits. If this is not the case, a neutral from the lighting circuit source should be run to the cabinet and make connection with the Relay Insert Panel. Only one (1) neutral connection is required.
5. Inspect the circuit wiring of the lighting circuits and confirm that all connections are properly made and are tight. Confirm that circuit and relay layout match the submittal drawings.

**Interconnect the Relay Cabinet - Step 2**

1. Set the ID of the Main Processor Unit (MPU) on the Command Module to a unique address. A block of DIP switches is provided for this purpose. Avoid duplicate addresses. The address will display on the small screen when the MPU is energized and functioning correctly.
2. If required, set the termination jumper to ON by sliding the jumper across the pins provided. These pins are located beside the forward facing LumaCan port in the bottom left of the MPU.
3. Interconnect the Power Supply and the MPU. Plug one of the supplied network cables into the first port on the power supply. This is labeled as 'MPU'. Plug the other end of the cable into the green LumaCan port at the top of the MPU.

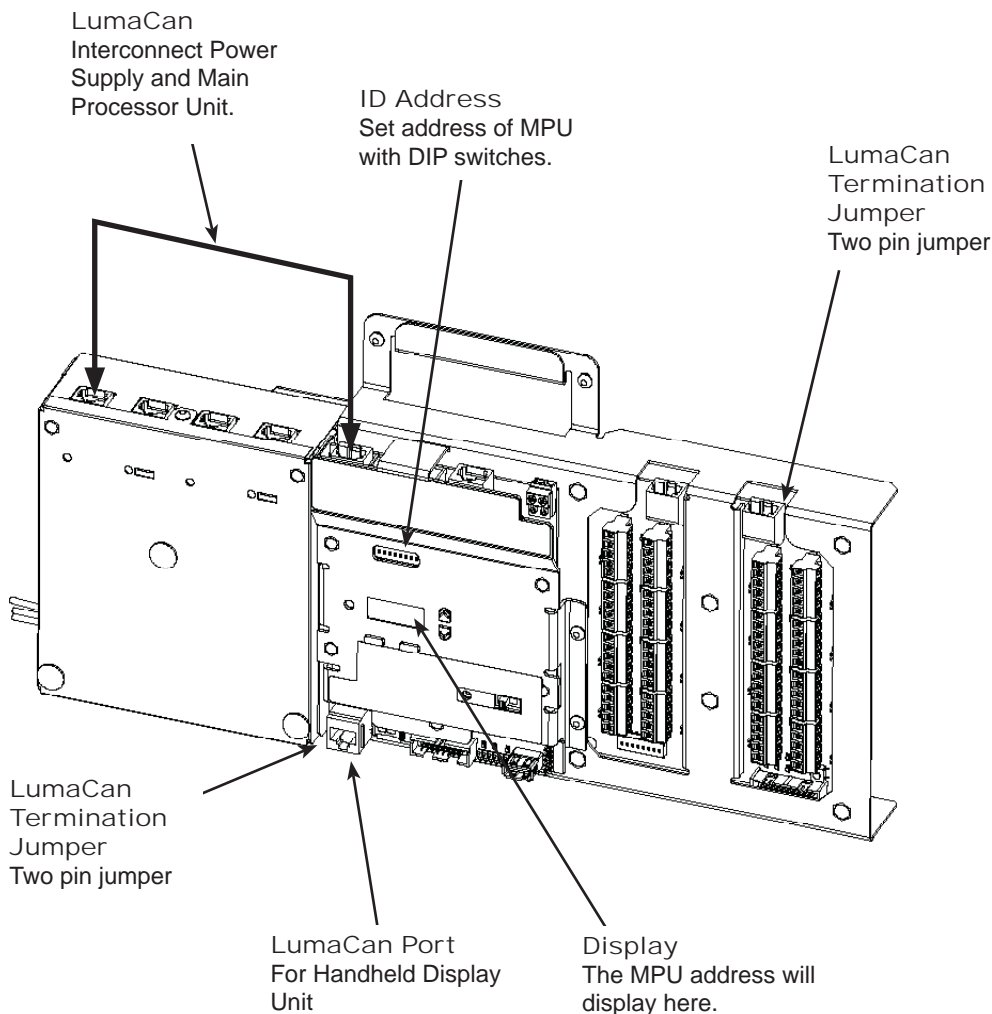

### Interconnect the Relay Cabinet - Step 3

1. Set the ID of the Low Voltage Input Card (AI) on the Command Module to a unique address. A block of DIP switches is provided for this purpose. Avoid duplicate addresses.
2. If required, set the termination jumper to ON by sliding the jumper across the pins provided. These pins are located beside the forward facing LumaCan port in the top left of the Low Voltage Input Card.
3. Interconnect the Power Supply and the Low Voltage Input Card. Plug one of the supplied network cables into the third port on the power supply. This is labeled as 'AI'. Plug the other end of the cable into the green LumaCan port at the top of the Low Voltage Input Card.

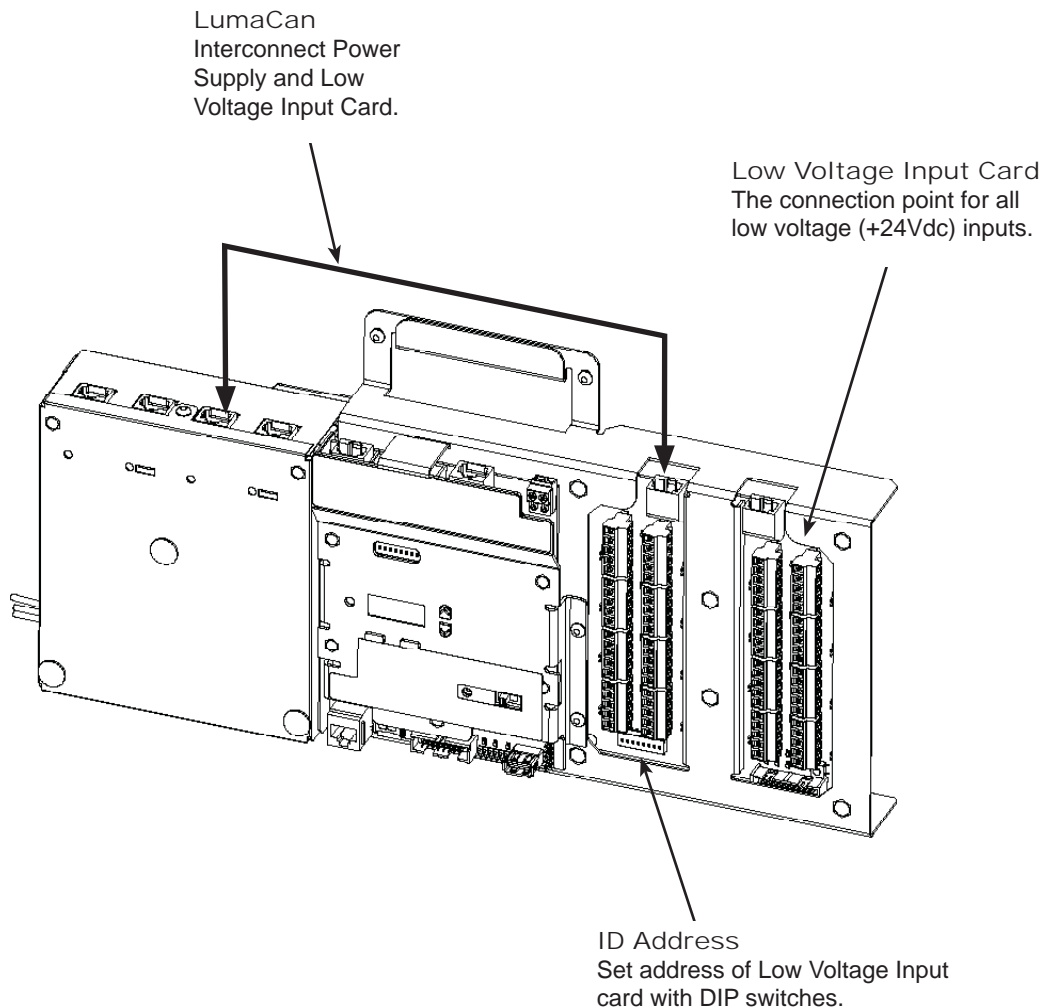

### Interconnect the Relay Cabinet - Step 4

1. Turn ON the power circuit feeding the relay cabinet Command Module. The green LEDs on the power supply will illuminate indicating +24Vdc output at the network connectors.
2. The green LEDs indicate power is present at the port connector. The second and fourth ports have a slide switch that will disconnect power before the connector. If power is turned OFF the LED will not illuminate. If a cable is connected to the port and the LED illuminates this indicates that power from another source is available on the cable. This is an allowed condition.
3. The MPU will beep during boot up and the Low Voltage Input Card will flash all of the troubleshooting red LEDs adjacent to the input points.
4. A flashing yellow heartbeat LED on both the MPU and AI indicates proper LumaCan configuration. If there is a duplicate ID the screen on the MPU will flash "DUP ADD" that means duplicate address.

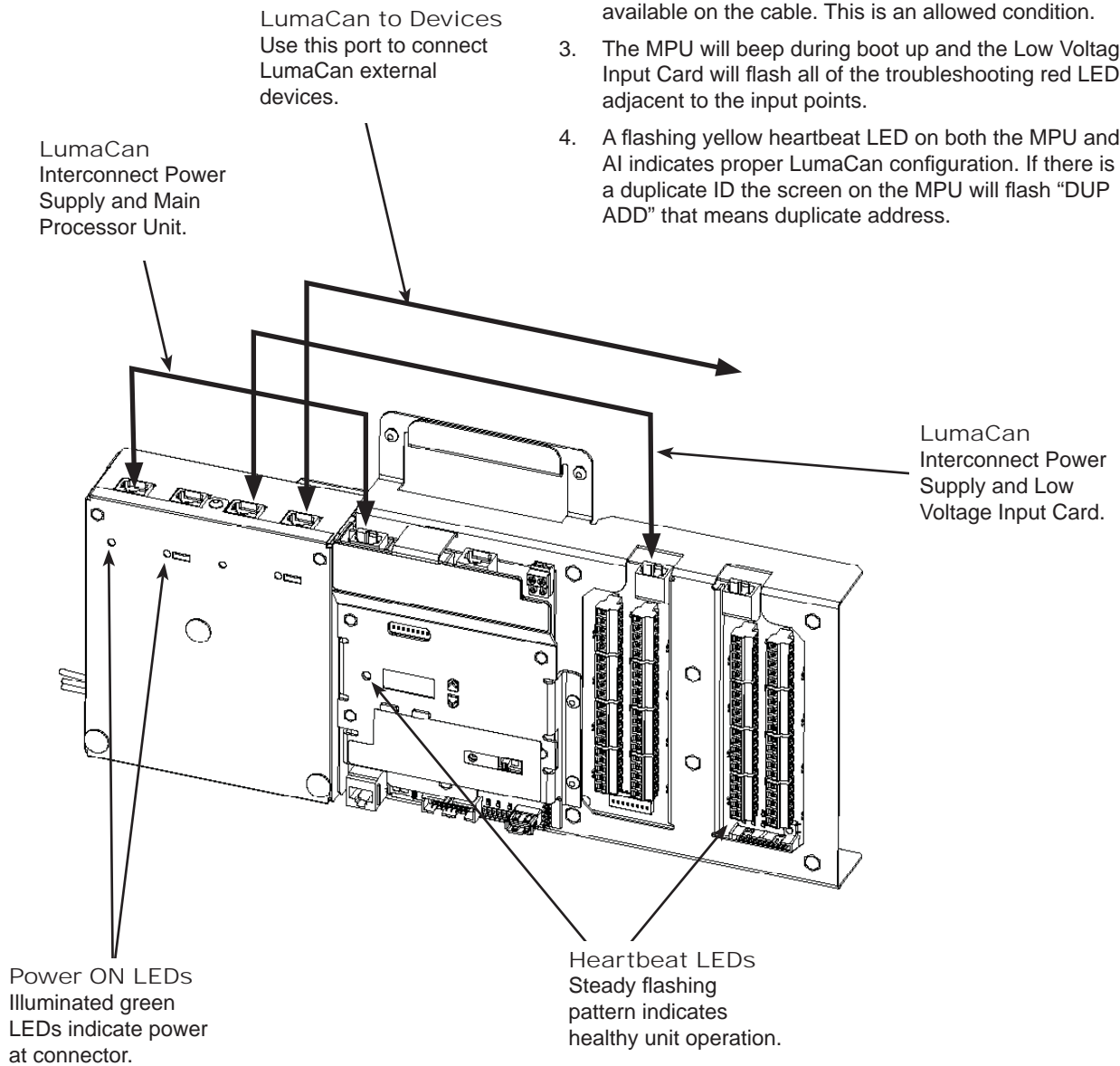

## The Start-Up Process

### Connect Digital Switches

1. Set the ID of the Digital Switch to a unique address. A block of DIP switches is provided for this purpose. Avoid duplicate addresses.
2. If required, set the termination jumper to ON by sliding the termination switch provided to the ON position. This switch is located on the back of the Digital Switch adjacent to the LumaCan ports.
3. Plug the LumaCan cables into the Digital Switch. Plug the network cables into either of the rear jacks on the switch, do not use the top port as this is reserved for the Handheld Display Module.
4. Devices must be connected in a daisy-chain and not a star pattern. Do not 'T' connect branches of LumaCan at the switches.
5. Digital Switches can be mounted in a single gang wall-box. The switches can be ganged together as required. Single gang snap on wall-plates are supplied with each Digital Switch.
6. A flashing yellow heartbeat LED on each Digital Switch indicates a function processor. If there is a duplicate ID the LED pattern will not be consistent.
7. LumaCan activity is indicated by flashing the green LED visible through the slot on side of the Digital Switch body.

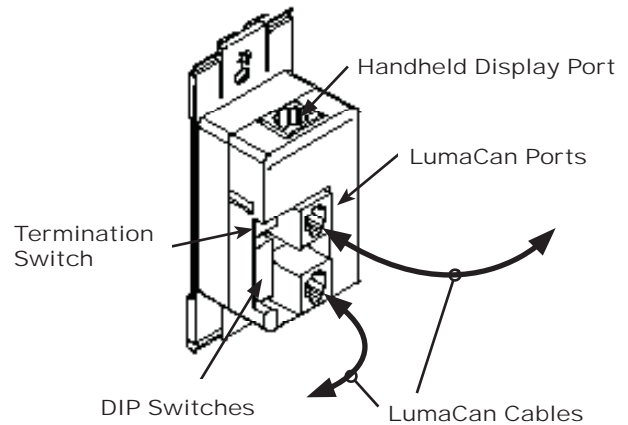

**Digital Switch  
Rear View**

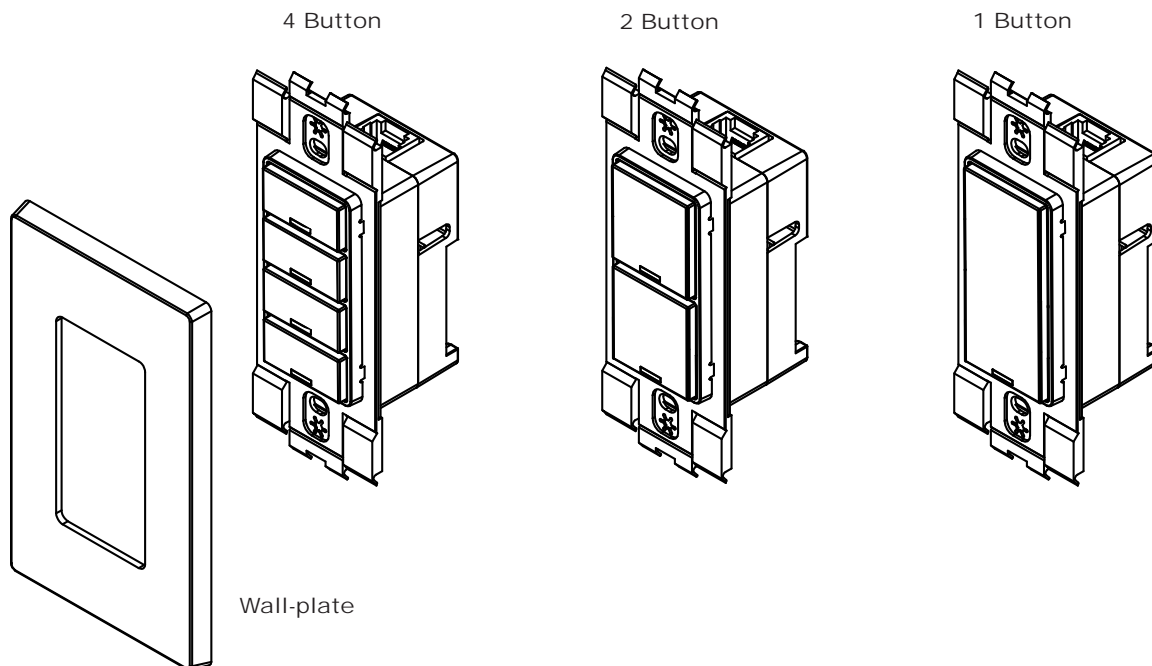

### ***LumaCan Check List***

- Field terminate and test all network cables. Check for proper pin configuration and connector integrity. Use the standard TYPE 'B' wiring configuration.
- The LumaCan network must have exactly two (2) termination jumpers or switches set to the ON position at the two (2) ends of the network. The termination jumpers or switches are available at the following locations:
  - A slide switch on the back of each Digital Switch is provided for this purpose. The rear plastic housing is marked with the switch position.
  - Each Command Module has a termination jumper that is shipped in the OFF position. It is located beside the LumaCan port on the front of the Main Processor Unit. Connecting the two (2) pins of the jumper together sets the termination ON.
  - The termination jumper on Low Voltage Input Card is located beside the LumaCan port. Connecting the two (2) pins of the jumper together sets the termination ON.
- The devices on the network must be daisy chained together. No "home runs" or star configurations are permitted.
- Each device on the LumaCan network must have a unique address. There are DIP switches that must be set to provide each device with an address. The device address is calculated by adding the values of the switches set in the ON position.
- When plugged in to an energized LumaCan network cable, the yellow 'heartbeat' LED on each device should be flashing the same pattern.
- The maximum length of a CAT6 LumaCan network is 1600 feet. Do not run cables adjacent to or in close proximity to high voltage connectors.
- LumaCan network cables must be contained in the low voltage area. Do not mix the cables with any of the high voltage conductors.

## The Start-Up Process

### Firmware Upgrade - Step 1

When the LumaCan network is stable and free of duplicate addresses, an upgrade of the device firmware should be performed. Return to the system Main cabinet or the most easily accessible relay cabinet. This local MPU must be updated first. Follow the steps below:

1. Contact Leviton Technical Support for instructions for downloading the firmware upgrade from the GreenMAX web-site. Save firmware on a flash memory stick or thumb-drive.
2. Plug thumb-drive into USB port on the front of the Command Module.
3. Press and hold the SELECT button on the MPU until the letters SAV appear on the screen.
4. Press the UP or DOWN arrows until the letters UPd appear on the screen. Then press SELECT.
5. Press the UP or DOWN arrows until the letters LoC appear on the screen. Then press SELECT.
6. The cursors on the screen will begin to cycle around screen, this indicates the process has begun.
7. The screen will return to scrolling the cabinet number when the process is complete.

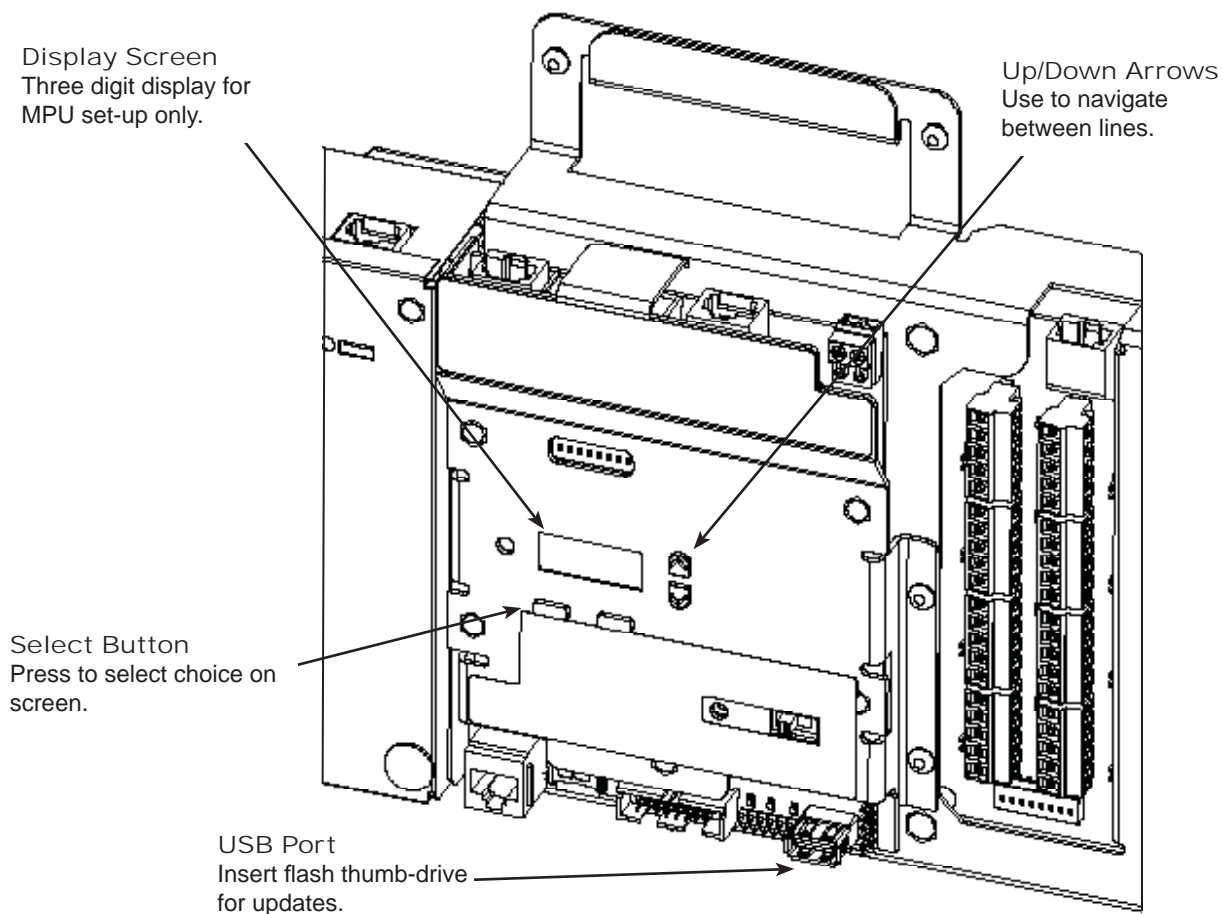



### Firmware Upgrade - Step 2

When the Local MPU (Step 1) has been successfully updated, all of the other devices on the network should be updated. Follow the steps below:

1. Plug thumb-drive into USB port on the front of the Command Module.
2. Press and hold the SELECT button on the MPU until the letters SAV appear on the screen.
3. Press the UP or DOWN arrows until the letters UPd appear on the screen. Then press SELECT.
4. Press the UP or DOWN arrows until the letters ALL appear on the screen. Then press SELECT.
5. The cursor on the screen will begin to cycle around screen, this indicates the process has begun. The process is fully automated and will not require any further interaction.
6. The screen will return to scrolling the cabinet number when the process is complete. The larger the system the longer this will take.

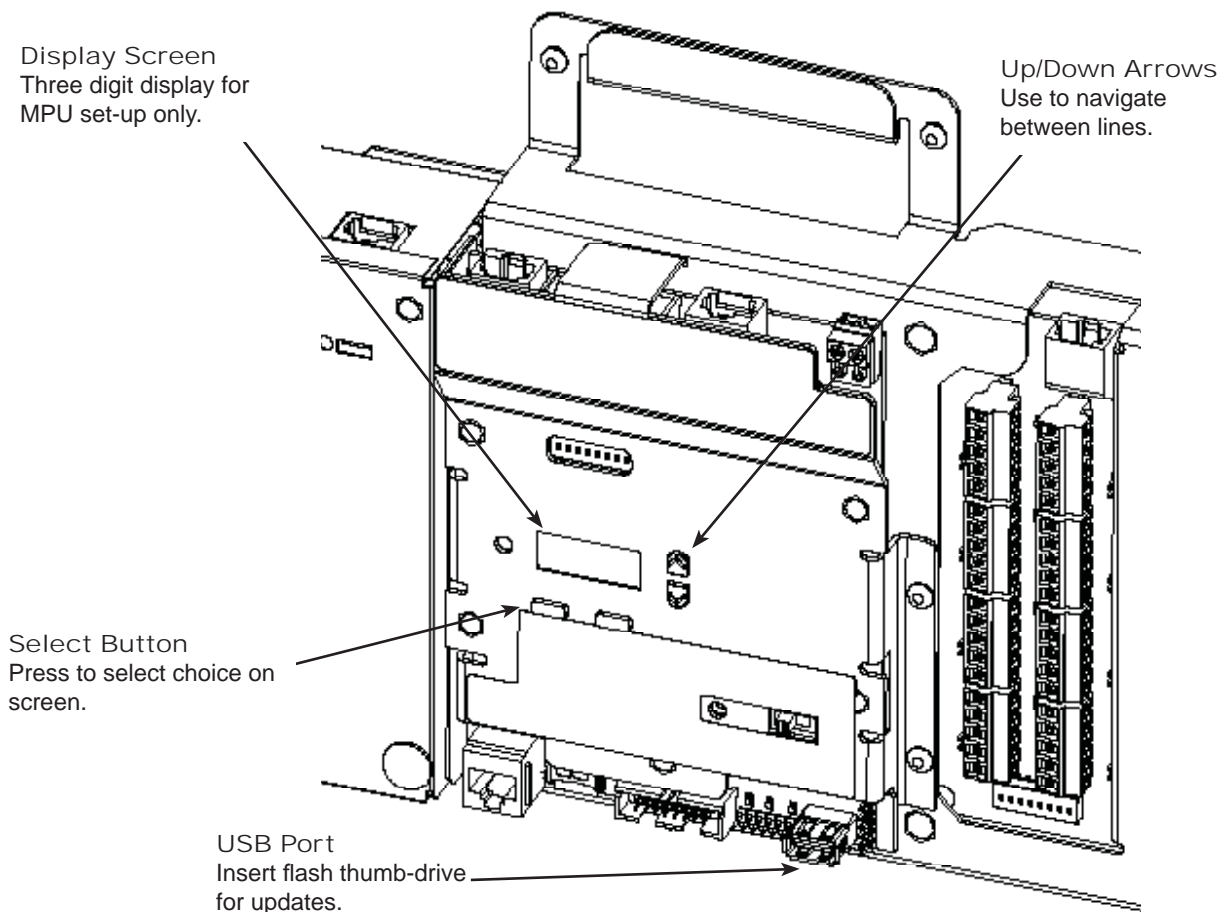



# Section 6 Programming Concepts



### Programming Basics

The flowchart on this page outlines the steps required to program a GreenMAX system.

#### AGENDA

Definition: A series of BEHAVIOR transitions that comprise a 24 hour period. This is a pattern of BEHAVIORS that mimics the use or operation of a building space.

- A total of 24 behavior transitions is allowed in a 24 hour period.
- Only the start time of a BEHAVIOR is required. The shortest duration between transitions is one (1) minute.
- The maximum number of AGENDAS is 32.

#### BEHAVIOR

Definition: The operational association or relationship between switches, occupancy sensors, and photocells in a given area.

- Behaviors are predetermined in the system.
- The list of Behaviors is found on the next few pages.

#### SCHEDULE

Definition: A weekly series of AGENDAS. This 7 day series will continue to operate until the system clock encounters an EXCEPTION DATE or the start date for a new SCHEDULE.

- The Start and End dates can be specified for the operational period of a SCHEDULE.
- The maximum number of SCHEDULES is 24.

#### EXCEPTION DATES

Definition: A date or series of dates that the current SCHEDULE will not apply and will not operate.

- There must be a corresponding additional SCHEDULE built to specify operation during the EXCEPTION DATE period.

#### AREA

Definition: A space or zone which corresponds to a building space or lighting circuit.

- Add Relays first

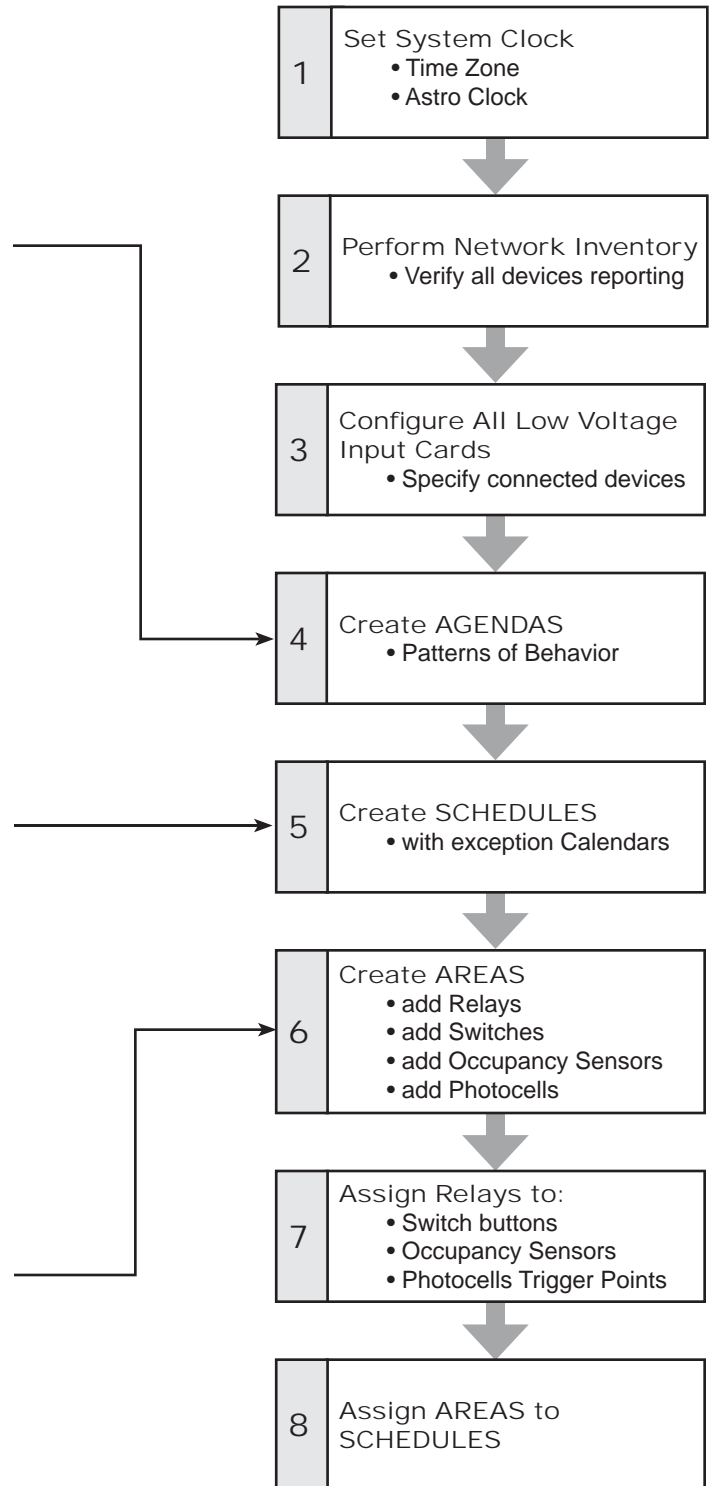

## Programming - Concepts

BEHAVIORS					
Number	Description	Occupancy Sensor	Photocell	Switch	Time
B1	Lights turned ON with the switch. Can be turned OFF with switch. Occupancy Sensor will turn OFF upon vacancy.	OFF	-	ON/OFF	-
B2	Lights turned ON with the Occupancy Sensor Can be turned OFF/ON with switch. Occupancy sensor will turn OFF upon vacancy	ON/OFF	-	ON/OFF	-
B3	Occupancy sensor turns lights ON/OFF.	ON/OFF	-	-	-
B4	Switch ON/OFF.	-	-	ON/OFF	-
B5	Time triggers a Blink Warn sequence. Switch interrupts sequence and starts interval timer. Will automatically turn Off relay if interval timer reaches zero.	-	-	ON/OFF	Blink/OFF
B6	Turn ON at specific time.	-	-	-	ON
B7	Turn OFF at specific time.	-	-	-	OFF
B8	Occupancy Sensor turns ON lights with occupancy. Measured light levels above Photocell trigger point turns OFF or keeps lights OFF, below set-point allows control by Occupancy Sensor. Occupancy Sensor turns OFF lights with vacancy.	ON/OFF	ON/OFF	-	-
B9	Switch turns ON/OFF lights. Measured light levels above Photocell trigger point turns OFF or keeps lights OFF, below set-point allows control by Switch and Occupancy Sensor. Occupancy Sensor will turn OFF lights upon vacancy	OFF	ON/OFF	ON/OFF	-
B10	Occupancy Sensor turns ON lights with occupancy. Measured light levels above Photocell trigger point turns OFF or keeps lights OFF, below set-point allows Occupancy Sensor control. Switch can turn ON/OFF lights by over-riding Occupancy Sensor control. Occupancy Sensor will turn OFF lights upon vacancy.	ON/OFF	ON/OFF	ON/OFF	-
B11	Switch ON/OFF. Measured light levels above Photocell trigger point turns OFF or keeps lights OFF, below set-point allows Switch control.	-	ON/OFF	ON/OFF	-
B12	Turn ON at specific time. Measured light levels above Photocell trigger point turns OFF or keeps lights OFF, below set-point allows Forced ON control.	-	ON/OFF	-	ON

### Create Agendas

Definition: A series of Behavior transitions that comprise a 24 hour period. This is a pattern of Behaviors that mimics the use or operation of a building space.

A total of 24 Behavior transitions is allowed in a 24 hour period. A transition is defined as a change to a new Behavior.

Only the start time of a Behavior is required. The shortest duration between transitions is one (1) minute.

Variable Parameters can be set for each transition. For example the delay time on an Occupancy Sensor may be set to a new value for the next Behavior in the Agenda.

The maximum number of AGENDAS is 32.

AGENDA Name:			
Transition No.	Time	Behavior	Variables
1			
2			
3			
4			
5			
6			
7			
8			
9			
10			
11			
12			
13			
14			
15			
16			
17			
18			
19			
20			
21			
22			
23			
24			

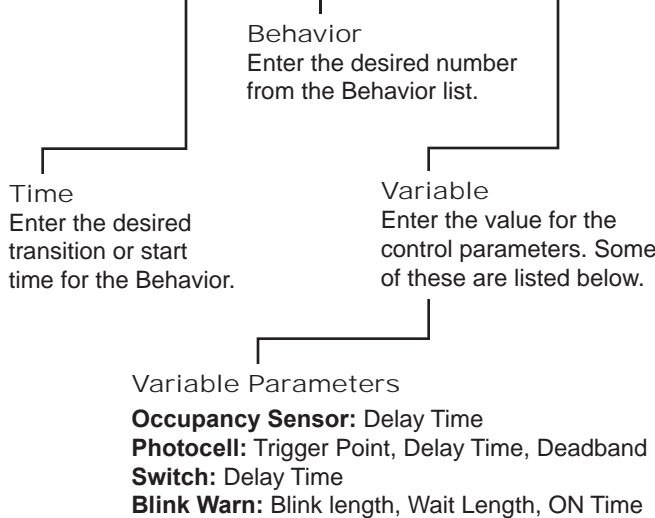

## Programming - Concepts

SCHEDULE Name:		Active Date Range			
		From		To	

← Date Range  
Enter Always or a  
Start and End date.

Monday	Tuesday	Wednesday	Thursday	Friday	Saturday	Sunday

← Active Days  
Check these boxes  
for each day that  
the AGENDA  
applies

Exception Dates			
1		17	
2		18	
3		19	
4		20	
5		21	
6		22	
7		23	
8		24	
9		25	
10		26	
11		27	
12		28	
13		29	
14		30	
15		31	
16		32	
(Holiday, Specific Date, Relative Date, Date Range)			

← Exception Dates  
Enter the Holiday,  
Date(s), Relative  
pattern of dates,  
or the appropriate  
Date Range. These  
are the dates that  
this Schedule  
does not apply or  
function on.



# Section 7 Programming HDU Usage

## Programming - HDU Usage

### Handheld Display Unit

All programming is done through the use of the Handheld Display Unit (HDU). The HDU plugs into the LumaCan at any available port in the system.

The HDU is powered by rechargeable batteries which provide up to 8 hours on a complete charge. The battery charging circuit of the HDU is activated whenever the HDU is plugged into the LumaCan. This charging circuit is self managing and will keep the batteries fully charged.

The status of the batteries and the source of the HDU power are indicated at the lower right corner of the display screen.

### Display Screen

High resolution graphic screen. Navigate about the screen using the Navigation Pad and enter data with the Alphanumeric Keypad. This is not a touchscreen.

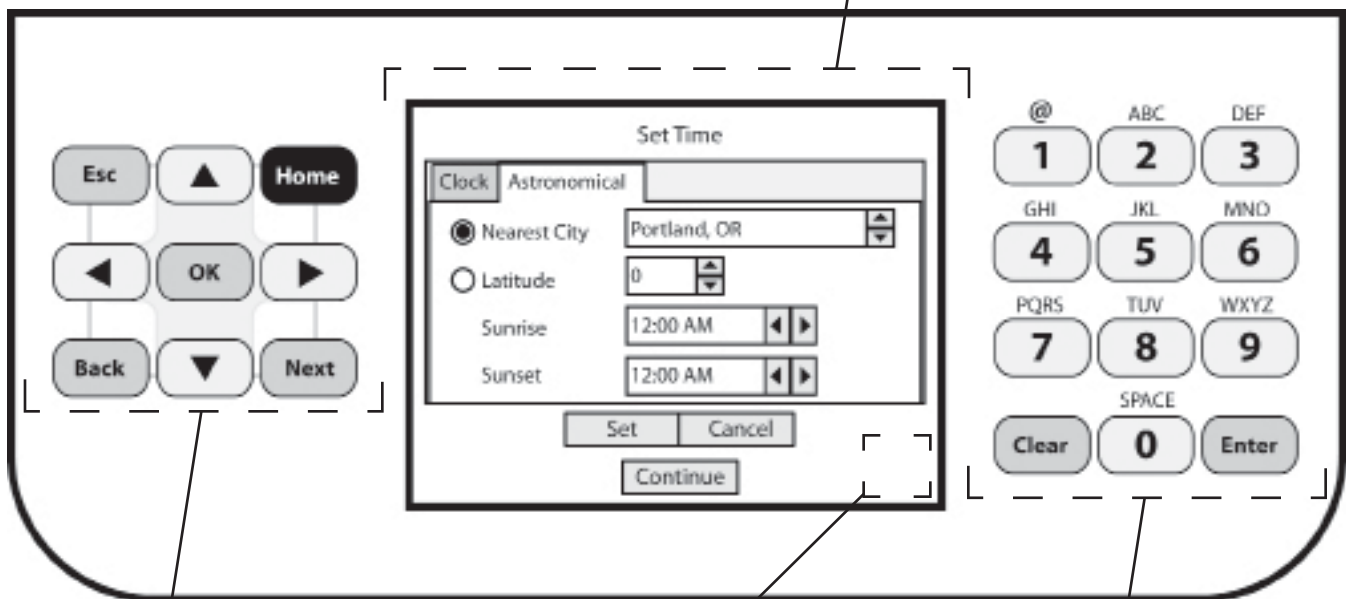

### Screen Navigation Keypad

Movement between areas or cells on the screen is accomplished with the button keypad on the HDU.

### Power Source Indicator

The battery charge level or the power from LumaCan icon displays in this corner of the display screen.

### Alphanumeric Keypad

Data entry is done with this keypad. Pressing the button multiple times changes the entry on the screen.

### Screen Content

The information displayed on the screen is organized into some standard components. The concepts for their presentation are outlined here.

#### Highlight

The current selection is highlighted by a dashed line around the button.

#### Tab Buttons

Some screens have informational layers that can be accessed by highlighting a tab and pressing OK or ENTER.

#### Scrolling Box

This type of box or cell presents populated lists to choose from. Use the UP or DOWN buttons to scroll through information. Once desired information is displayed in the cell, select it by pressing OK/ENTER or NEXT/BACK.

#### Combination Scrolling Box

This type of box or cell presents settings that can be manipulated several ways. The LEFT/RIGHT buttons move from character to character while UP/DOWN increments the characters. Data can be directly entered to overwrite the highlighted characters. Once desired information is displayed in the cell, select it by pressing OK/ENTER or NEXT/BACK.

#### Buttons

These are simple buttons. Their operation is described by the label that appears on the button. For example:  
 Cancel - cancels and ignores all data changes made.  
 Set - accepts the data changes and entries displayed.  
 Continue - moves to next screen.

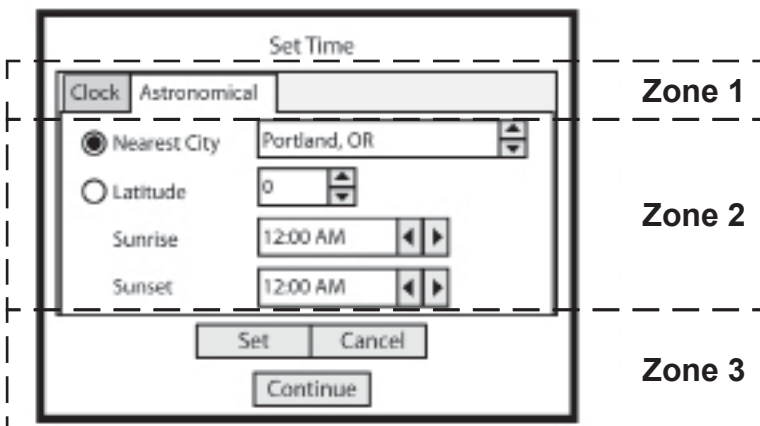
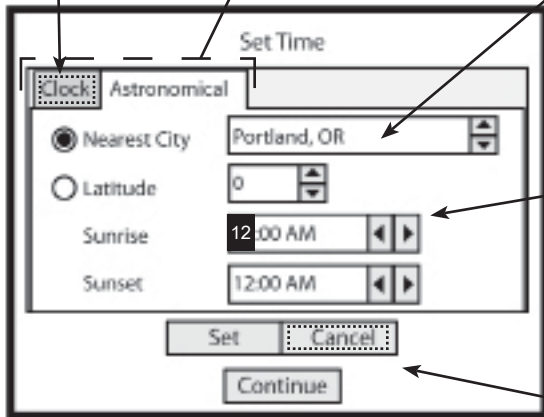

#### Zones

The display screen is organized into three general zones. Moving from zone to zone is accomplished by pressing the NEXT/BACK buttons.

Once inside a zone you may navigate between cells, boxes, tabs, or buttons with the LEFT/RIGHT/UP/DOWN arrow buttons.

**Navigation Keypad**

All movement of the cursor is controlled by the Navigation Keypad. When the individual buttons are pressed they will click to acknowledge input. This keypad is best operated by your left thumb if you holding the unit in your hands.

The button functions are outlined in the diagram below. In most cases the button should only be pressed once. These buttons provide dual functions based on the cursor location on the screen.

If the cursor is in a data field, the keypad will manipulate the characters in the field.

If the cursor is in one of the on-screen buttons, the keypad will move the cursor from location to location.

**ESC**

This is the ESCAPE button.  
*Nav:* Back to a previous position or screen.  
*Data:* It will escape from the immediate entry.

**UP**

This is the UP button.  
*Nav:* Move upward between fields within a zone.  
*Data:* Press to capitlize the next character entry or scroll through choices.

**Home**

This is the HOME button.  
*Nav:* Returns to the Home screen.

**Right**

This is the RIGHT button.  
*Nav:* Moves between fields within a zone.  
*Data:* Move to next character space.

**Left**

This is the LEFT button.  
*Nav:* Moves between fields within a zone.  
*Data:* Press to move cursor left of the current character.

**Back**

This is the BACK button.  
*Nav:* Moves between zones on the screen.  
*Data:* It will escape from the immediate entry.

**Down**

This is the Down button.  
*Nav:* Move downward between fields within a zone.  
*Data:* Press to remove capitlization of the next character entry or scroll through choices.

**OK**

This is the OK button and is the same operation as the ENTER.  
*Nav:* Accepts highlighted choice.  
*Data:* Accepts highlighted choice.

**Next**

This is the NEXT button and is the opposite of the BACK button.  
*Nav:* Moves between zones on the screen.  
*Data:* It will escape from the immediate entry.

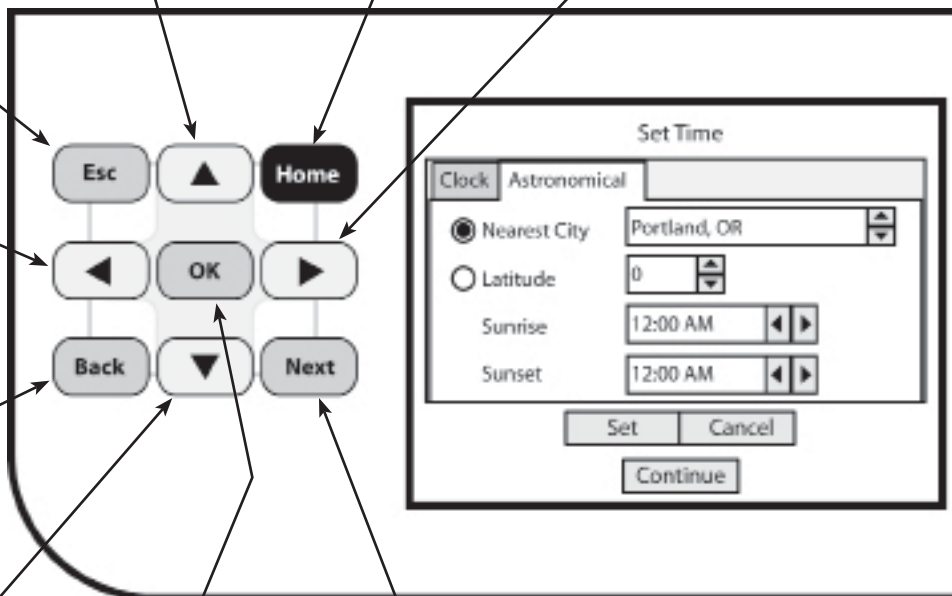

### Alphanumeric Keypad

This keypad operates similar to the way a cellular telephone keypad operates for text messaging. Each time a button is pressed, a different character will appear on the screen. Each button is assigned a short series of characters. The series will cycle through each and repeat automatically.

A pause between button presses will move the cursor to the next character position. Pressing the LEFT arrow will backspace the cursor and erase the character.

To enter a capitalized or upper case character, press the UP arrow prior to entering the new character. To turn off the uppercase function, press the DOWN arrow.

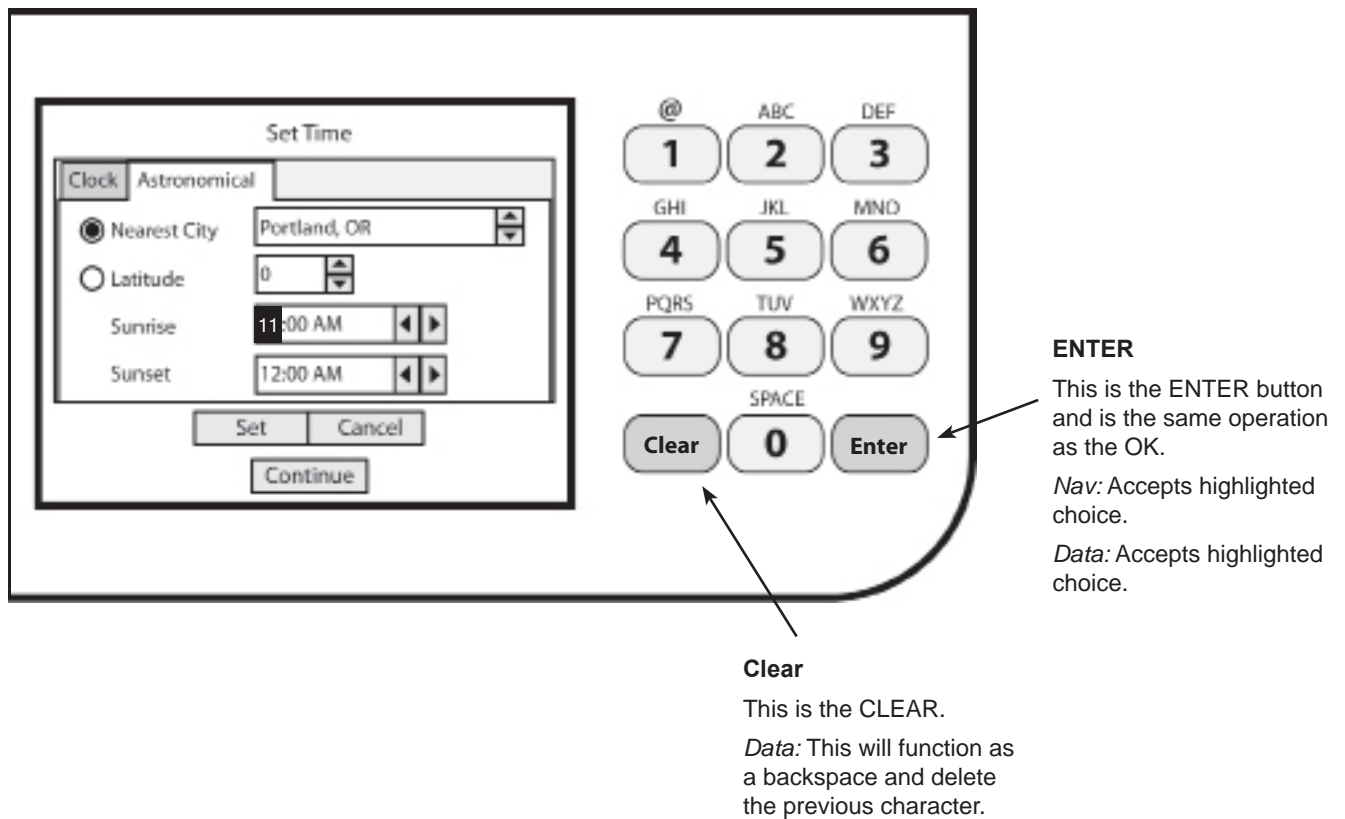

### Data Entry Techniques

Many of the data fields in the display screens require the entry of data such as names and labels. All of this information is stored in the GreenMAX system and is accessible from any HDU that is plugged into the system. However only one HDU should be plugged into the system at a time.

It is important to know how to enter and manipulate information through the HDU. Many of these techniques follow the pattern of modern text messaging.

The example on this page demonstrates how an AREA name can be entered into a data field.

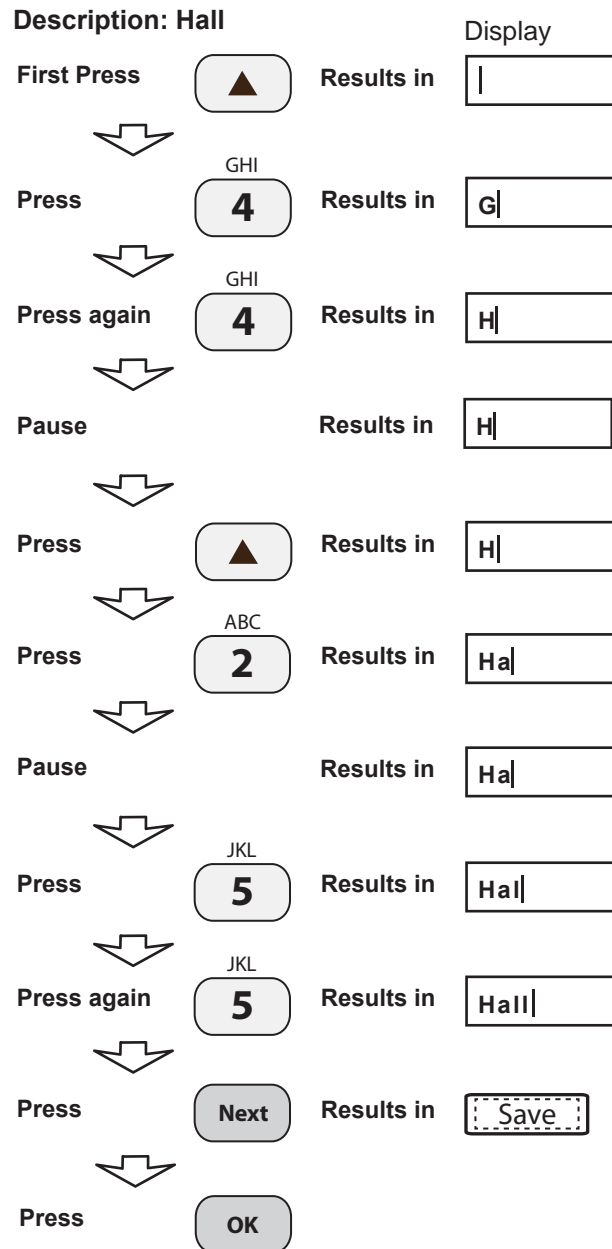
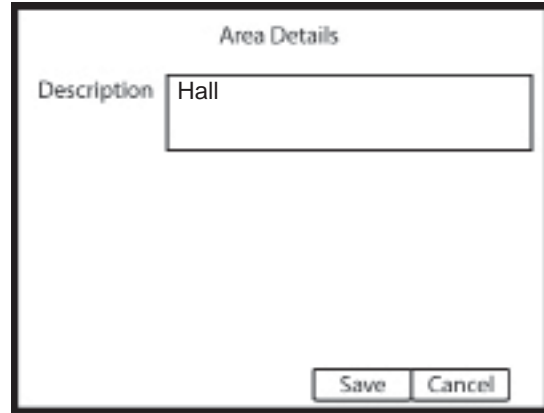

# Section 8 Programming Details

### Offline Screen

If this screen is displayed on the HDU it is indicating that there is a problem with the LumaCan network.

Check the following items and correct any of the deficiencies.

1. Check and test all cables for proper pin configuration.
2. Confirm that the run of LumaCan is continuous, without breaks or interruptions.
3. Check that all cables are properly seated in the LumaCan jacks. All devices should display a blinking amber status LED. To correct, unplug and reconnect the device or press the device reset button.
4. Check all addresses on the LumaCan to ensure there are no duplicate numbers. All devices ship with the default address of zero (0), this will prevent the device from participating on the network and must be changed.
5. Check the location of the end of line termination jumpers. There must be two (2) jumpers set on each run of LumaCan. The digital switches have a termination slide switch on the back of the unit for convenient jumper setting. Each MPU and Low Voltage Input Card have a pair of pins and a jumper provided for this purpose. No more than two (2) jumpers should be set on a run.
6. Confirm that all SD Cards are properly seated in their slots.
7. Confirm that all power supplies are energized and that there green LEDs are illuminated.
8. Confirm that the HDU is plugged into and part of the LumaCan network.

When all of these have been checked and corrections made, press the highlighted CONNECT screen button.



Press



If CONNECT is pressed but the screen below appears this indicates that a problem exists. Correct and try again.



Press



To clear warning message.



### Project Name Screen

This screen will appear when communication with the LumaCan has been established.

Enter the name of the project in the Data field as required.

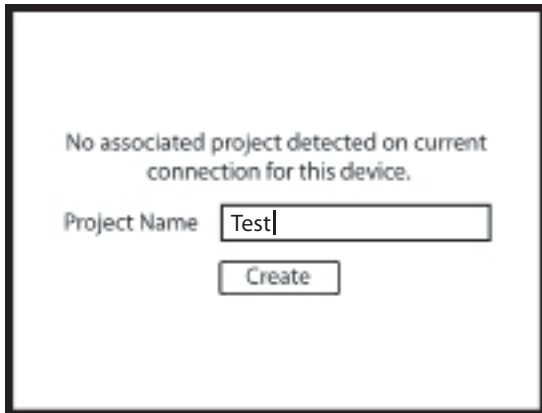

Press



When complete, press NEXT to highlight the CREATE screen button.

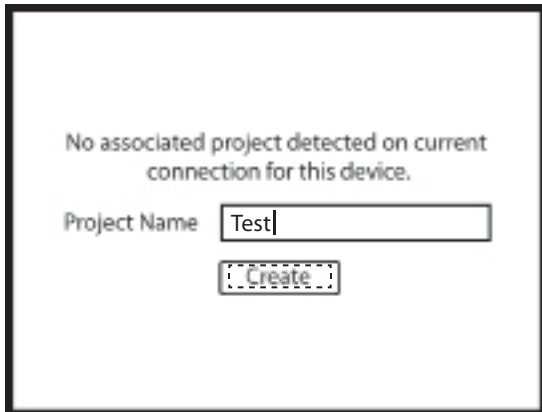

Press



To accept information and create project. A progress bar will be displayed to indicate that a Project is being created on the system. An inventory of the network will be conducted. See Inventory screen for explanation.

### Inventory Screen

The system will perform and create a Network Inventory. All devices that are connected to the LumaCan network and active will be listed on the resulting tree diagram.

Each device will report the following information:

1. Node ID- this is the address that is set by the DIP switches.
2. Device Type - this will list the type of device such as digital switch with button count.
3. Firmware Version - the current loaded firmware version will be listed here. All similar types of devices should be at the same firmware version level.

A summary message will appear at the end of the procedure. Press the OK button to close message box.

Review the Network Inventory list and make any corrections necessary to match this list to the actual installed devices.

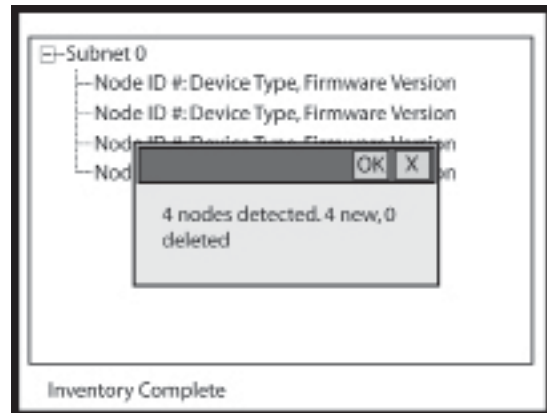

Press



To clear result message.

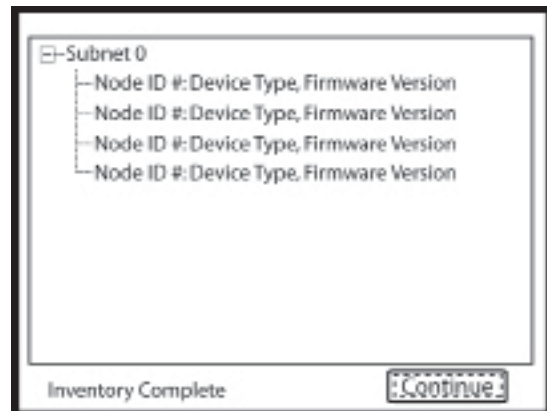

Press



To accept information and continue.

System will automatically progress to the Set Time screen.

### Set Time Screen

This screen will appear automatically and display the current settings of the system clock.

Make all necessary changes and complete by clicking the Set screen button.

Time zone can be selected by pressing the NEXT button to highlight the cell and using the UP or DOWN arrow to scroll through the choices.

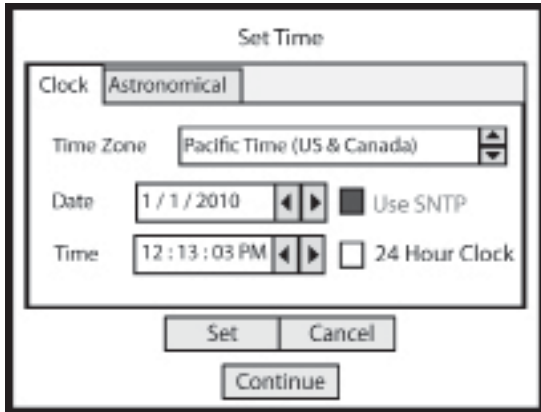

Press



When complete, press NEXT to highlight the SET screen button.



Press

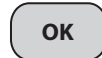

To accept information and save the Time settings.



Press



When complete, press NEXT to highlight the CONTINUE screen button.



Press



To advance to the next screen.

### System Defaults

#### Permanent Time Master

During the initial set up of the GreenMAX system, the Permanent Time Master for the network can be specified. This is an optional setting and if used, should be the most conveniently located cabinet in the system. This will be the cabinet that synchronizes the time clocks of all devices on the network.

#### Blink Warn Settings

The Blink Warn function for the system is activated by check the box beside Blink Warn Enabled. The settings listed below will be distributed to all relays in the system. The settings can be changed on an individual relay basis elsewhere in the program. The variables are:

1. BW Time - this is the duration of the OFF blink in seconds
2. BW Delay - this is the length of time the system waits to receive a button press that indicates the space is occupied. No button press will turn the relays off.
3. BW Override (Ovrd) - this is the length of time the relays remain on before the cycle continues again.

#### Emergency Action

The response of all of the relays to an input at the cabinet emergency input terminal block is set here. This setting will be distributed to all of the relays in the system. The setting can be changed on an individual relay basis elsewhere in the program. The three (3) types of response are:

1. Ignore - the relays will not change state. They will stay in the position they were in prior to the input signal.
2. ON - the relays will close to turn ON the loads.
3. OFF - the relays will open to turn of the loads.

Set System Defaults

Permanent Time Master  
Panel@0:16

Blink Warn Enabled

BW Time: 0.5 Sec.

BW Delay: 1 Min.

BW Ovrd: 4 Min.

Emergency Action: Ignore

Set Cancel

Press



When complete, press NEXT to highlight the SET screen button.



Press



To accept information and save the settings. This will also advance to the next screen.

Schedule Details

Name

Date Range Effective

Mon	<input type="button" value="Inactive"/>
Tue	<input type="button" value="Inactive"/>
Wed	<input type="button" value="Inactive"/>
Thu	<input type="button" value="Inactive"/>
Fri	<input type="button" value="Inactive"/>
Sat	<input type="button" value="Inactive"/>
Sun	<input type="button" value="Inactive"/>

Calendars

Areas



## Section 9

# Frequently Asked Questions

***Frequently Asked Questions*****What do the green LEDs on the Command Module Power Supply indicate?**

There are four (4) green LEDs on the Power Supply that will illuminate when there is output power (+24Vdc) at the corresponding connection port. Two (2) of the connection ports are provided power at all times. Two (2) of the connection points have selectable power output that is configured by the slide switch adjacent to the LED window to the OFF position. This turns off the power from this individual port. If the LED illuminates when the cable is plugged in, this indicates that power from another power supply is available on the cable. This is an acceptable condition or configuration.

**How are the GreenMAX devices powered?**

The Power Supplies of the GreenMAX system are provided with each Command Module and Remote Low Voltage Input Cabinet. When interconnected, the Main Processor Unit (MPU) and Low Voltage Input Card (AI) derive their power from the Power Supply directly. The Digital Switches and the Handheld Display Unit are powered when connected to the LumaCan network.



### How are LumaCan Addresses set?

The maximum number of LumaCan addresses on a network is limited to 250 unique addresses starting with ID 1.

There are dip switches that must be set to provide each device with an address. The device address is calculated by adding the values of the switches set in the ON position.

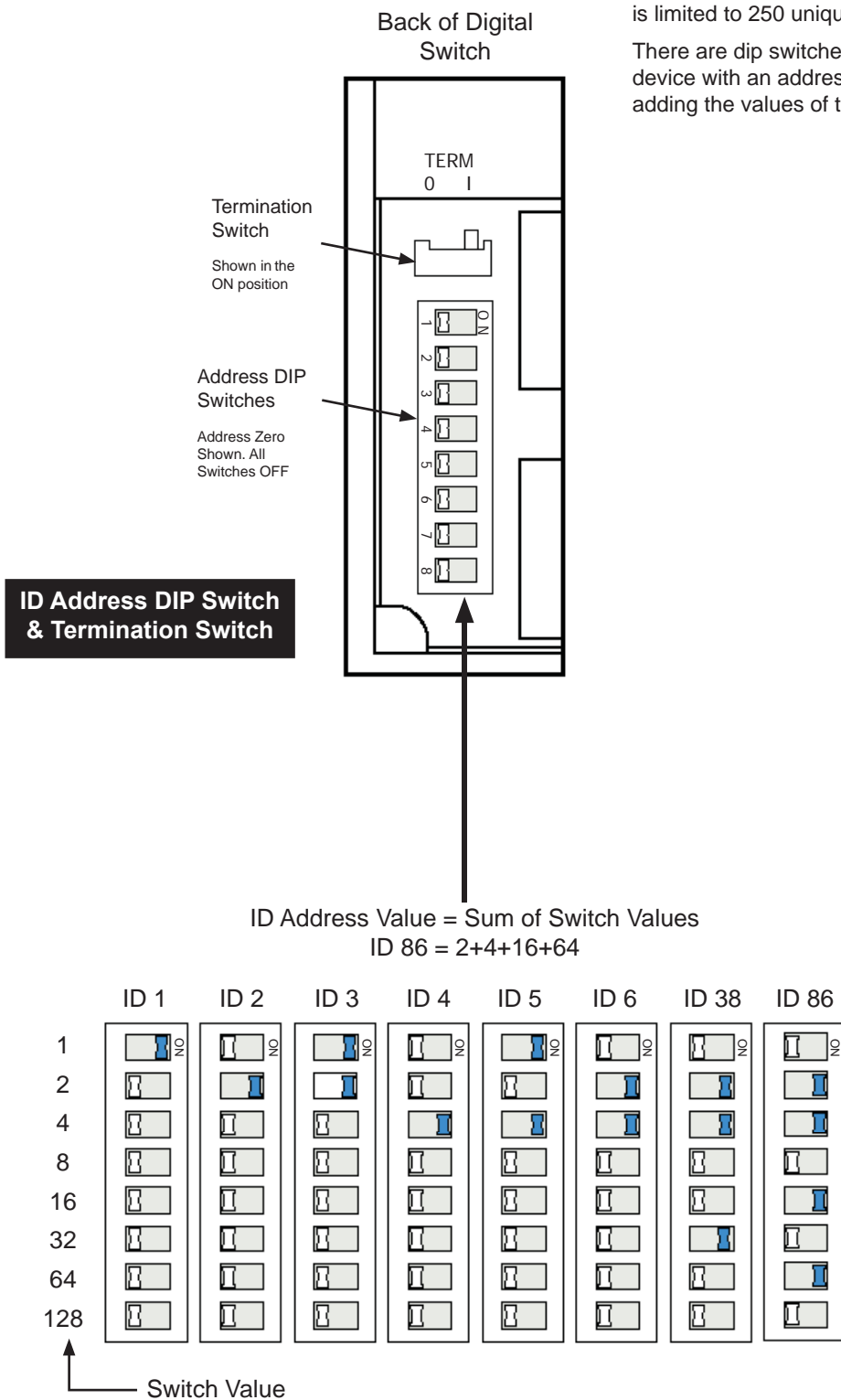

***What type of data cable is required for LumaCan?***

Definitions:

**CAT6 Cable - PREFERRED**

A 4 pair high performance cable that consists of twisted pair conductors. This cable standard is much higher than that of CAT5 cable and improves the quality of manufacture, twist pattern of the wire pairs, and heavier gage wire. It was designed for performance characteristics of up to 250MHz.

**CAT5E Cable**

A 4 pair high performance cable that consists of twisted pair conductors. This cable type is typically used for data transmission. The twisting of the pairs provides the cable a certain amount of immunity from unwanted interference.

**CAT5 Cable**

Do not use this type of cable.

The table below lists the required properties for the Category types. The cable you select for the installation must meet or exceed the parameters listed.

Characteristic	PREFERRED	
	Category 6	Category 5E
Specified frequency range	1 - 250 MHz	1 - 100 MHz
Attenuation	36 dB	24 dB
NEXT	33.1 dB	30.1 dB
Power-sum NEXT	30.2 dB	27.1 dB
ACR	-2.9 dB	6.1 dB
Power-sum ACR	-5.8 dB	3.1 dB
ELFEXT	15.3 dB	17.4 dB
Power-sum ELFEXT	12.3 dB	14.4 dB
Return loss	8 dB	10 dB
Propagation delay	546 nsec	548 nsec
Delay Skew	50 nsec	50 nsec
	PREFERRED	

### ***Glossary of Terms***

The maximum number of LumaCan addresses on a network is limited to 250 unique addresses starting with ID 1.

There are dip switches that must be set to provide each device with an address. The device address is calculated by adding the values of the switches set in the ON position.

#### **Blink Warn**

This is the Blink Warn Functionality which briefly blinks OFF the lights to warn room occupants that the lights are about to be turned off, turns the lights ON and waits for a button press to o.

#### **BW Time**

Blink Warn Time. The BW Time is the length of the warning OFF duration. The time units are seconds. This is user configurable.

#### **BW Delay**

Blink Warn Delay. The BW Delay is the length of the waiting ON period. It is during this time that occupants may press a switch button to postpone the turning OFF of the lights. The time units are minutes. This is user configurable.

#### **BW Ovr**

Blink Warn Override. The BW Ovr is the length of the temporary ON period that starts when occupants press a switch button. When this period of time has elapsed, the Blinkwarn sequence will start again. The time units are minutes. This is user configurable.



## Section 10 Ratings

### **Ratings**

Single-Pole Relay Ratings

#### **RELAY-1TB**

**RELAY-1CB** (Return To Closed)

Single-Pole, Latching Relay Module 50/60 Hz.

- 24-277VAC, 20A, Tungsten Halogen Incandescent
- 24-277VAC, 30A, Ballast
- 347VAC, 20A, Ballast
- 120VAC, 1/2 Hp Motor
- 240/277VAC, 1 Hp Motor

**RELAY-1DS** Single-Pole Dimming 0-10Vdc, Latching Relay Module, 50/60 Hz.

24-277VAC, 30A, Ballast

347VAC, 20A, Ballast

Class 1 Control 0-10 VDC, 50 mA max sinking

Control wire range #18-#12AWG copper

Control wire terminal torque: 14 IN-LBS

Suitable for use on a circuit capable of delivering not more than 25,000A RMS SYM. at 277VAC max when protected by a circuit breaker having an interrupting capacity of not less than 25,000A RMS SYM. at 277VAC and an ampere rating of not more than 30A.

Suitable for use on a circuit capable of delivering not more than 18,000A RMS SYM. at 347VAC max when protected by a circuit breaker having an interrupting capacity of not less than 18,000A RMS SYM. at 347VAC and an ampere rating of not more than 20A.

Double-Pole Relay Ratings

#### **RELAY-2TB**

**RELAY-2CB** (Return To Closed)

Double-Pole, Latching Relay Module 50/60 Hz.

- 208/240VAC, 20A, Tungsten Halogen Incandescent
- 208/240/480VAC, 30A, Ballast
- 600VAC, 20A, Ballast
- 208/240/480VAC, 1HP Motor

Suitable for use on a circuit capable of delivering not more than 25,000A RMS SYM. at 240VAC max when protected by a circuit breaker having an interrupting capacity of not less than 25,000A RMS SYM. at 240VAC and an ampere rating of not more than 30A.

Suitable for use on a circuit capable of delivering not more than 14,000A RMS SYM. at 480VAC max when protected by a circuit breaker having an interrupting capacity of not less than 14,000A RMS SYM. at 480VAC and an ampere rating of not more than 30A.

## Ratings

### Command Module

#### Power Supply

70 Watts, Class 2

Input: 100-277Vac 50/60Hz

Output: +24Vdc

Ports 1 & 2 Combined 1500 mA ea.

Ports 3 & 4 Combined 1500 mA ea.

#### Command Module

**Input:** +24Vdc 1 Watt (plus connect loads),  
Class 2

#### Analog Input Board

Input: +24Vdc 1 Watt (plus connect loads),  
Class 2

Output: +24Vdc

8 Ports at 40 mA ea. (RPM08-108)

16 Ports at 40 mA ea. (RPM16-116)

### Enclosure Environmental

NEMA1

Ambient Temperature Range: 0°C - 40°C  
(32°F - 104°F)

Relative Humidity: < 90% non-condensing

### Listings

UL508, UL924, cUL, CEC Title 24 compliant,  
ASHRAE 90.1 compliant

### Warranty

Relay Modules backed by 10-year warranty

Relay Panels backed by 2-year warranty

### Remote Input Cabinet

#### Power Supply

70 Watts, Class 2

Input: 100-277Vac 50/60Hz

Output: +24Vdc

Ports 1 & 2 Combined 1500 mA ea.

Ports 3 & 4 Combined 1500 mA ea.

### Analog Input Board

Input: +24Vdc 1 Watt (plus connected loads),  
Class 2

Output: +24Vdc

8 Ports at 40 mA ea. (RLV08-110)

16 Ports at 40 mA ea. (RLV16-110)

### Enclosure Environmental

NEMA1

Ambient Temperature Range: 0°C - 40°C  
(32°F - 104°F)

Relative Humidity: < 90% non-condensing

### Listings

UL508, UL924, cUL, CEC Title 24 compliant,  
ASHRAE 90.1 compliant

### Warranty

Cabinet backed by 2-year warranty

Leviton Manufacturing Co., Inc. Lighting Management  
Systems

20497 SW Teton Avenue, Tualatin, OR 97062

Telephone: 1-800-736-6682 • FAX: 503-404-5594 •

Tech Line (6:00AM-4:00PM P.S.T. Monday-Friday):

1-800-959-6004



Set Time

Clock:

Nearest City:

Latitude:

Sunrise:

Sunset:





# GreenMAX<sup>®</sup>

## Programming Manual

### Daylight Harvesting and Dimming Module



Built by the industry, for the industry.



# GreenMAX Programming Manual

## Daylight Harvesting and Dimming Module

V2.14

<u>INDEX</u>		<u>PAGE</u>
SECTION 1	Behavior Descriptions and Settings	
Behavior 1	Dimming with Manual Control with Auto OFF	4
Behavior 2	Dimming with Manual Control with Auto ON/OFF	5
Behavior 3	Dimming with Auto ON/OFF	6
Behavior 4	Dimming with Manual ON/Bright/Dim/OFF Control	7
Behavior 6	Dimming ON Command	8
Behavior 7	Dimming Off Command	9
Behavior 8	Dimming with Auto ON/OFF and Light Hold Off	10
Behavior 9	Dimming with Manual ON/Bright/Dim/OFF, Auto Off, and Light Hold Off	11
Behavior 10	Daylight Harvesting with Photocell, Manual ON/Bright/Dim/OFF, Auto ON/OFF	12
Behavior 11	Dimming with Manual ON/OFF and Light Hold Off	13
SECTION 2	Programming Details	
Overview	Behavior 4	15
Step 1	Behavior 4 – Create a Schedule	16
Step 2	Behavior 4 – Configure Devices	21
Step 3	Behavior 4 – Create an Area	24
Step 4	Behavior 4 – 4 Switch Buttons	27
Overview	Behavior 10	35
Step 1	Behavior 10 – Create a Schedule	36
Step 2	Behavior 10 – Configure Devices	41
Step 3	Behavior 10 – Create an Area	46
Step 4	Behavior 10 – Switch Buttons	49
Step 5	Behavior 10 – Occupancy Sensors	57
Step 6	Behavior 10 - Photocells	60
SECTION 3	Support Information	
	Definitions	64
	Photocell Signals and Calibration	65
	Low Voltage Connection Diagrams	66

FILENAME

GREENMAX DIMMING AND  
DAYLIGHT HARVESTING  
MANUAL V2.14D.VSD

# Section 1

## Behavior Descriptions and Settings

**B1 – Dimming with Manual Control and Auto Off**

Operation Description

1. Occupancy Sensor will, upon vacancy, turn Off the lights after delay period expires.
2. Manual operation of dimming module. Switch buttons can be configured for ON/Bright/Dim/OFF function.
3. The Bright and Dim buttons provide fade Up/Down control of the light level.

-- B1 – DEVICE SETTINGS --						
<b>Switch Button Settings</b>	<b><u>Button Type</u></b>	<b><u>Description</u></b>	<b><u>Initial Level</u></b>	<b><u>Delay</u></b>	<b><u>Override</u></b>	<b><u>Assign to</u></b>
	On DS Button	<i>Enter as required</i>	<i>Set to a value*</i>	<i>Set to a value**</i>	'N/A'	Relay or Group
	Bright DS Button	<i>Enter as required</i>	<i>Set to a value*</i>	<i>Set to a value**</i>	'N/A'	Relay or Group
	Dim DS Button	<i>Enter as required</i>	<i>Set to a value*</i>	<i>Set to a value**</i>	'N/A'	Relay or Group
	Off DS Button	<i>Enter as required</i>	<i>Set to a value*</i>	<i>Set to a value**</i>	'N/A'	Relay or Group
<p><i>*Range 0 to 100%. A complete Off of relay is represented by 0%.</i>  <i>**This value is set to created a timed switch button. Time will start when the button is pressed. When this time expires, lights will fade to Off.</i></p>						
<b>Occupancy Sensor</b>	<b><u>Device Type</u></b>	<b><u>Description</u></b>	<b><u>Initial Level</u></b>	<b><u>Delay</u></b>	<b><u>Override</u></b>	<b><u>Assign to</u></b>
	Occupancy Sensor	<i>Enter as required</i>	<i>Ignore</i>	<i>Set to a value*</i> <i>Range 0 to 256</i>	'N/A'	Relay or Group
<p><i>*This Delay setting is the typical occupancy sensor delay before lights will turn off. It is in addition to the value set in the device itself</i></p>						

**NOTES**

1. This Dimming Behavior applies only to the Dimming and Sensing relays.
2. This behavior can be used with any quantity of buttons and is not exclusive to the 4 button Switch.
3. This behavior can utilize either a Digital switch or a Low Voltage switch button.
4. There is no photocell involved with this behavior.
5. Switch buttons can be configured as Timed Switch buttons.
6. The Occupancy Sensor will turn the lights Off only.

**B2 – Dimming with Manual Control and Auto ON/Off**

## Operation Description

1. Occupancy Sensor will, upon occupancy, turn On the lights to the configured Initial Level.
2. Manual operation of dimming module. Switch buttons can be configured for ON/Bright/Dim/OFF function.
3. The Bright and Dim buttons provide fade Up/Down control of the light level.
4. Occupancy Sensor will, upon vacancy, turn Off the lights after delay period expires.

-- B1 – DEVICE SETTINGS --						
Switch Button Settings	<b>Button Type</b>	<b>Description</b>	<b>Initial Level</b>	<b>Delay</b>	<b>Override</b>	<b>Assign to</b>
	On DS Button	<i>Enter as required</i>	<i>Set to a value*</i>	<i>Set to a value**</i>	'N/A'	Relay or Group
	Bright DS Button	<i>Enter as required</i>	<i>Set to a value*</i>	<i>Set to a value**</i>	'N/A'	Relay or Group
	Dim DS Button	<i>Enter as required</i>	<i>Set to a value*</i>	<i>Set to a value**</i>	'N/A'	Relay or Group
	Off DS Button	<i>Enter as required</i>	<i>Set to a value*</i>	<i>Set to a value**</i>	'N/A'	Relay or Group
<p><i>*Range 0 to 100%. A complete Off of relay is represented by 0%.</i></p> <p><i>**This value is set to created a timed switch button. Time will start when the button is pressed. When this time expires, lights will fade to Off.</i></p>						
Occupancy Sensor	<b>Device Type</b>	<b>Description</b>	<b>Initial Level</b>	<b>Delay</b>	<b>Override</b>	<b>Assign to</b>
	Occupancy Sensor	<i>Enter as required</i>	<i>Set to a value**</i> <i>Range 0 to 100%</i>	<i>Set to a value*</i> <i>Range 0 to 256</i>	'N/A'	Relay or Group
<p><i>*This Delay setting is the typical occupancy sensor delay before lights will turn off. It is in addition to the value set in the device itself</i></p> <p><i>**This is percentage of output of the 0-10VDC module</i></p>						

**NOTES**

1. This Dimming Behavior applies only to the Dimming and Sensing relays.
2. This behavior can be used with any quantity of buttons and is not exclusive to the 4 button Switch.
3. This behavior can utilize either a Digital switch or a Low Voltage switch button.
4. There is no photocell involved with this behavior.
5. Switch buttons can be configured as Timed Switch buttons.
6. The Occupancy Sensor will turn the lights both On and Off.
7. The lights will fade from level to level including both On and Off.

**B3 – Dimming with Auto ON/OFF**

Operation Description

1. Occupancy Sensor will, upon occupancy, turn On the lights to the configured Initial Level.
2. Occupancy Sensor will, upon vacancy, turn Off the lights after delay period expires.

-- B3 – DEVICE SETTINGS --						
	<u>Device Type</u>	<u>Description</u>	<u>Initial Level</u>	<u>Delay</u>	<u>Override</u>	<u>Assign to</u>
Occupancy Sensor	Occupancy Sensor	Enter as required	Set to a value** Range 0 to 100%	Set to a value* Range 0 to 256	'N/A'	Relay or Group
		*This Delay setting is the typical occupancy sensor delay before lights will turn off. It is in addition to the value set in the device itself **This is percentage of output of the 0-10VDC module				

**NOTES**

1. This Dimming Behavior applies only to the Dimming and Sensing relays.
2. There are no photocells or switches involved with this behavior.
3. The Occupancy Sensor will turn the lights both On and Off.
7. The lights will fade between On and Off.



**B4 – Dimming with Manual ON/Bright/Dim/OFF**

## Operation Description

1. Manual operation of dimming module.
2. Switch buttons can be configured for ON/Bright/Dim/OFF function.
3. The Bright and Dim buttons provide fade Up/Down control of the light level.

-- B4 – DEVICE SETTINGS --						
	<u>Button Type</u>	<u>Description</u>	<u>Initial Level</u>	<u>Delay</u>	<u>Override</u>	<u>Assign to</u>
Switch Button Settings	On DS Button	<i>Enter as required</i>	<i>Set to a value*</i>	<i>Set to a value**</i>	'N/A'	Relay or Group
	Bright DS Button	<i>Enter as required</i>	<i>Set to a value*</i>	<i>Set to a value**</i>	'N/A'	Relay or Group
	Dim DS Button	<i>Enter as required</i>	<i>Set to a value*</i>	<i>Set to a value**</i>	'N/A'	Relay or Group
	Off DS Button	<i>Enter as required</i>	<i>Set to a value*</i>	<i>Set to a value**</i>	'N/A'	Relay or Group
<p><i>*Range 0 to 100%. A complete Off of relay is represented by 0%.</i></p> <p><i>**This value is set to created a timed switch button. Time will start when the button is pressed. When this time expires, lights will fade to Off.</i></p>						

**NOTES**

1. This Dimming Behavior applies only to the Dimming and Sensing relays.
2. This behavior can be used with any quantity of buttons and is not exclusive to the 4 button Switch.
3. This behavior can utilize either a Digital switch or a Low Voltage switch button.
4. There is no photocell or occupancy sensor involved with this behavior.
5. Switch buttons can be configured as Timed Switch buttons.

**B6 – Dimming ON Command**

## Operation Description

1. Turn On at a specific time.

**-- B6 – DEVICE SETTINGS --**

*No devices required*

**NOTES**

1. This Dimming Behavior applies only to the Dimming and Sensing relays.
2. There are no photocells, occupancy sensors, or switches involved with this behavior.

**B7 – Dimming OFF Command**

## Operation Description

1. Turn Off at a specific time.

**-- B7 – DEVICE SETTINGS --**

*No devices required*

**NOTES**

1. This Dimming Behavior applies only to the Dimming and Sensing relays.
2. There are no photocells, occupancy sensors, or switches involved with this behavior.

**B8 – Dimming with Auto ON/OFF and Light Hold Off**

Operation Description

1. Occupancy Sensor will, upon occupancy, turn On the lights to the configured Initial Level.
2. Occupancy Sensor will, upon vacancy, turn Off the lights after delay period expires.
3. System monitors Photocell input signal and compares it to the Photocell Target Level. Lights will turn Off or will be held Off above the Target Level. Below the Target Level, lights will be permitted to turn On.

-- B8 – DEVICE SETTINGS --							
Occupancy Sensor	<b><u>Device Type</u></b>	<b><u>Description</u></b>	<b><u>Initial Level</u></b>	<b><u>Delay</u></b>	<b><u>Override</u></b>	<b><u>Assign to</u></b>	
	Occupancy Sensor	<i>Enter as required</i>	<i>Set to a value** Range 0 to 100%</i>	<i>Set to a value* Range 0 to 256</i>	'N/A'	Relay or Group	
<p><i>*This Delay setting is the typical occupancy sensor delay before lights will turn off. It is in addition to the value set in the device itself</i></p> <p><i>**This is percentage of output of the 0-10VDC module</i></p>							
Photocell	<b><u>Device Type</u></b>	<b><u>Description</u></b>	<b><u>Daylight Harvesting Speed</u></b>	<b><u>Deadband</u></b>	<b><u>Artificial Zero</u></b>	<b><u>Target Level</u></b>	<b><u>Assign to</u></b>
	Closed Loop	<i>Enter as required</i>	Ignore	<i>Set to a value 10% is typical</i>	'Disabled'	<i>Set to required*</i>	Relay or Group
<p><i>* Target level is percentage of photocell input range and is the desired measured light level in the space</i></p>							

**NOTES**

1. This Dimming Behavior applies only to the Dimming and Sensing relays.
2. There is no switch involved with this behavior.
3. The Occupancy Sensor will turn the lights both On and Off if the light level is below the Photocell Target Level.
7. The lights will fade between On and Off.

**B9 – Dimming with Manual ON/Bright/Dim/OFF, Auto OFF and Light Hold Off**

## Operation Description

1. Occupancy Sensor will turn OFF lights with vacancy detection after delay period expires.
2. Switch buttons can be configured for ON/Bright/Dim/OFF function. The Bright and Dim buttons provide fade Up/Down control of the light level.
3. System monitors Photocell input signal and compares it to the Photocell Target Level. Lights will turn Off or will be held Off above the Target Level. Below the Target Level, lights will be permitted to turn On.

-- B9 – DEVICE SETTINGS --							
Switch Button Settings	<b>Button Type</b>	<b>Description</b>	<b>Initial Level</b>	<b>Delay</b>	<b>Override</b>	<b>Assign to</b>	
	On DS Button	<i>Enter as required</i>	<i>Set to a value*</i>	<i>Set to a value**</i>	'N/A'	Relay or Group	
	Bright DS Button	<i>Enter as required</i>	<i>Set to a value*</i>	<i>Set to a value**</i>	'N/A'	Relay or Group	
	Dim DS Button	<i>Enter as required</i>	<i>Set to a value*</i>	<i>Set to a value**</i>	'N/A'	Relay or Group	
	Off DS Button	<i>Enter as required</i>	<i>Set to a value*</i>	<i>Set to a value**</i>	'N/A'	Relay or Group	
<p><i>*Range 0 to 100%. A complete Off of relay is represented by 0%.</i></p> <p><i>**This value is set to created a timed switch button. Time will start when the button is pressed. When this time expires, lights will fade to Off.</i></p>							
Occupancy Sensor	<b>Device Type</b>	<b>Description</b>	<b>Initial Level</b>	<b>Delay</b>	<b>Override</b>	<b>Assign to</b>	
	Occupancy Sensor	<i>Enter as required</i>	<i>Ignore</i>	<i>Set to a value*</i> <i>Range 0 to 256</i>	'N/A'	Relay or Group	
<p><i>*This Delay setting is the typical occupancy sensor delay before lights will turn off. It is in addition to the value set in the device itself</i></p>							
Photocell	<b>Device Type</b>	<b>Description</b>	<b>Daylight Harvesting Speed</b>	<b>Deadband</b>	<b>Artificial Zero</b>	<b>Target Level</b>	<b>Assign to</b>
	Closed Loop	<i>Enter as required</i>	<i>Ignore</i>	<i>Set to a value</i> <i>10% is typical</i>	'Disabled'	<i>Set to required*</i>	Relay or Group
<p><i>* Target level is percentage of photocell input range and is the desired measured light level in the space</i></p>							

**NOTES**

1. This Dimming Behavior applies only to the Dimming and Sensing relays.
2. This behavior can be used with any quantity of buttons and is not exclusive to the 4 button Switch.
3. This behavior can utilize either a Digital switch or a Low Voltage switch button.
3. The Occupancy Sensor will turn the lights Off.
7. The lights will fade between On and Off.

**B10 – Daylight Harvesting with Photocell, Manual ON/Bright/Dim/OFF, Auto ON/OFF**

## Operation Description

1. Occupancy Sensor will turn On lights with detection of Area occupancy. Vacancy will turn Off the lights after delay period expires.
2. Switch buttons can be configured for ON/Bright/Dim/OFF function. The Bright and Dim buttons provide a temporary manual override of the light level. The duration of the manual override is configurable.
3. The Photocell Target Level drives the daylight harvesting by continuously measuring the light level and adjusting the output of the Dimming Module accordingly.

-- B10 – DEVICE SETTINGS --							
Switch Button Settings	<b>Button Type</b>	<b>Description</b>	<b>Initial Level</b>	<b>Delay</b>	<b>Override</b>	<b>Assign to</b>	
	On DS Button	<i>Enter as required</i>	<i>Ignore</i>	'N/A'	'N/A'	Relay or Group	
	Bright DS Button	<i>Enter as required</i>	<i>Ignore</i>	'N/A'	<i>Set to a value* Range 0 to 256</i>	Relay or Group	
	Dim DS Button	<i>Enter as required</i>	<i>Ignore</i>	'N/A'	<i>Set to a value* Range 0 to 256</i>	Relay or Group	
	Off DS Button	<i>Enter as required</i>	<i>Ignore</i>	'N/A'	'N/A'	Relay or Group	
<i>*The Override time represents the length of time the temporary manual override of the photocell Target Level will be in effect. Pressing these buttons will initialize the override by increasing or decreasing the light level.</i>							
Occupancy Sensor	<b>Device Type</b>	<b>Description</b>	<b>Initial Level</b>	<b>Delay</b>	<b>Override</b>	<b>Assign to</b>	
	Occupancy Sensor	<i>Enter as required</i>	<i>Ignore</i>	<i>Set to a value* Range 0 to 256</i>	'N/A'	Relay or Group	
<i>*This Delay setting is the typical occupancy sensor delay before lights will turn off. It is in addition to the value set in the device itself</i>							
Photocell	<b>Device Type</b>	<b>Description</b>	<b>Daylight Harvesting Speed</b>	<b>Deadband</b>	<b>Artificial Zero</b>	<b>Target Level</b>	<b>Assign to</b>
	Closed Loop	<i>Enter as required</i>	'Fast'	<i>Set to a value 10% is typical</i>	'Disabled'	<i>Set to required*</i>	Relay or Group
<i>* Target level is percentage of photocell input range and is the desired measured light level in the space</i>							

**NOTES**

1. This Dimming Behavior applies only to the Dimming and Sensing relays.
2. The Closed Loop photocell is the best suited for this application.
3. The Target Level of the photocell drives the Daylight Harvesting.
4. The system monitors the input value from the photocell and compares it to the photocell Target Level. If the input value is below the Target Level the DS relay module will increase output. If the input level is above the target Level, the DS relay module will decrease output.
5. The Daylight Harvesting Speed setting will determine the speed of response from the system for changes in light levels. There are three settings; Fast, Slow, test.
6. When the occupancy sensor turns on the relay in response to someone entering the Area, the lights will fade up to the Photocell Target Level or the last known level if a manual override is still in effect.
7. All of the devices listed above must be configured for this Behavior to operate properly.

**B11 – Dimming with Manual ON/OFF and Light Hold Off**

## Operation Description

1. Switch buttons can be configured for ON/Bright/Dim/OFF function. The Bright and Dim buttons provide fade Up/Down control of the light level.
3. System monitors Photocell input signal and compares it to the Photocell Target Level. Lights will turn Off or will be held Off above the Target Level. Below the Target Level, lights will be permitted to turn On.

-- B11 – DEVICE SETTINGS --							
Switch Button Settings	<b>Button Type</b>	<b>Description</b>	<b>Initial Level</b>	<b>Delay</b>	<b>Override</b>	<b>Assign to</b>	
	On DS Button	<i>Enter as required</i>	<i>Set to a value*</i>	<i>Set to a value**</i>	'N/A'	Relay or Group	
	Bright DS Button	<i>Enter as required</i>	<i>Set to a value*</i>	<i>Set to a value**</i>	'N/A'	Relay or Group	
	Dim DS Button	<i>Enter as required</i>	<i>Set to a value*</i>	<i>Set to a value**</i>	'N/A'	Relay or Group	
	Off DS Button	<i>Enter as required</i>	<i>Set to a value*</i>	<i>Set to a value**</i>	'N/A'	Relay or Group	
<p><i>*Range 0 to 100%. A complete Off of relay is represented by 0%.</i></p> <p><i>**This value is set to created a timed switch button. Time will start when the button is pressed. When this time expires, lights will fade to Off.</i></p>							
Photocell	<b>Device Type</b>	<b>Description</b>	<b>Daylight Harvesting Speed</b>	<b>Deadband</b>	<b>Artificial Zero</b>	<b>Target Level</b>	<b>Assign to</b>
	Closed Loop	<i>Enter as required</i>	Ignore	<i>Set to a value</i> <i>10% is typical</i>	'Disabled'	<i>Set to required*</i>	Relay or Group
<p><i>* Target level is percentage of photocell input range and is the desired measured light level in the space</i></p>							

**NOTES**

1. This Dimming Behavior applies only to the Dimming and Sensing relays.
2. This behavior can be used with any quantity of buttons and is not exclusive to the 4 button Switch.
3. This behavior can utilize either a Digital switch or a Low Voltage switch button.
3. There is no Occupancy Sensor involved with this behavior.
7. The lights will fade between On and Off.

# Section 2

## Programming Details



## B4 Dimming with Manual Control - Programming Overview

This section will present the typical steps required to program a GreenMAX system to provide Dimming functionality.

The fundamental components required for Dimming control are:

- GreenMAX Dimming and Switching Relay Modules – RELAY-1DS
- 4 Button Switch - either Low Voltage or Digital

### Office Dimming Schedule

#### **Monday to Sunday**

8:00am	Office Dimming	B4
		Lights will be controlled by:
		Switch Buttons (4): On Button – turn ON at 80%
		Bright Button
		Dim Button
		Off Button
5:00pm	OFF sweep	B7
		Lights will be turned OFF

### Programming Checklist

- Create a schedule.
- Configure switch buttons. (On/Bright/Dim/Off)
- Create an Area.
- Assign a schedule to an Area.
- Add relays to Area.
- Add switch buttons to area.

- Key On screen button.
- <Add> Label of onscreen entry field
- Name- Button on keypad
- NEXT Button on keypad
- Details Screen Name

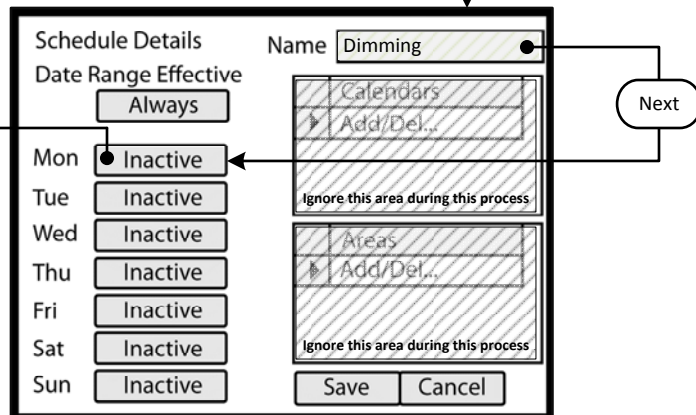
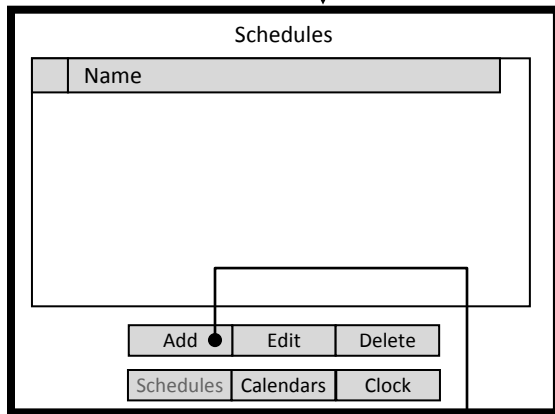

**Step 1: Create a Schedule**

Programming operation of the GreenMAX is based on running Schedules. A Schedule can be considered a default seven (7) day pattern of operation.

The following rules apply:

- An Area requires a Schedule to operate.
- Only one Schedule can be assigned to an Area.
- A Schedule can be assigned to multiple Areas.
- Schedules reside in the GreenMAX system and can be accessed through the Handheld Display Unit (HDU).

**Step 1.1**

To create a Schedule, enter the <Control> section of the Handheld Display Unit (HDU) software.

Understanding the Screen

There are three sections of the HDU software. The sections under the buttons are:

- <Monitor> - Used to check the system time/date, relay status
- <Control> - Access Scheduling
- <Config> - Configuration of system including set-up of Areas

**Step 1.2**

The first <Control> HDU screen lists the existing Schedules available in your GreenMAX System. The screen shown indicates that there are no Schedules available or created.

By navigating to <Add> and pressing OK, this will initiate the creation of a Schedule.

Other Options

To modify an existing Schedule, highlight the appropriate Schedule on the list. Navigate to <Edit> and press OK, to initiate the modification of the selected Schedule.

To delete an existing Schedule, highlight the appropriate Schedule on the list. Navigate to <Delete> and press OK, to erase the selected Schedule.

**Step 1.3**

The screen is entered with the -Name- field highlighted. Enter the desired name of your Schedule using the alpha numeric keypad of the HDU. When complete, press the NEXT button on the navigation keypad. The cursor will advance to the <Monday> button.

Understanding the Screen

The label value of "Inactive" shown on the <Monday> button indicates that there is currently no Behavior transitions programmed for this day. The same is true for all days, Monday through Sunday, of this schedule.

There are no Exception Calendars associated with this Schedule.

This Schedule has not been assigned to any Areas.

- Key
- <Add> On screen button.
- Name- Label of onscreen entry field
- NEXT Button on keypad
- Details Screen Name

**Agenda For Schedule: Dimming**

Start Time	Behavior	Day
	Add	<input checked="" type="checkbox"/> Mon
		<input type="checkbox"/> Tue
		<input type="checkbox"/> Wed
		<input type="checkbox"/> Thu
		<input type="checkbox"/> Fri
		<input type="checkbox"/> Sat
		<input type="checkbox"/> Sun

OK Cancel

OK

**Agenda Behavior Transition Detail**

Transition to behavior: Behavior 1

Absolute Time 12:00 PM

Offset N/A N/A N/A

Swt Delay N/A BW Time N/A

Occ Delay N/A BW Delay N/A

PC Delay N/A BW Ovrld N/A

OK Cancel

Next

Next

**Agenda Behavior Transition Detail**

Transition to behavior: Behavior 4

Absolute Time 8:00 AM

Offset N/A N/A N/A

Ignore this area during this process

Swt Delay N/A BW Time N/A

Occ Delay N/A BW Delay N/A

PC Delay N/A BW Ovrld N/A

OK Cancel

Next

**Step 1.4**

The screen is entered at the first line of the Agenda. There are a total of 24 Behavior Transition times available per day. Clicking OK will advance to the Behavior Transition Detail screen.

Understanding the Screen

*This Agenda only applies to Monday, as shown here.*

<OK> - Will save the settings or changes

<Cancel> - Will discard the changes

**Step 1.5**

The Behavior Transition Detail screen is entered at the Behavior selection box. Use the UP or DOWN arrows to choose the desired Behavior. Consultate the Behavior chart in the Manual for descriptions. For this example change to Behavior 4.

Understanding the Screen

<Offset> provides access to Sunrise and Sunset settings for Astronomical clock times.

-BW Time-, -BW Delay-, -BW Ovrld- - These are the Blinkwarn settings that apply to this Behavior Transition only. They will override the Global Blinkwarn Settings set in the System Settings section.

**Step 1.6**

Use a combination of the UP and DOWN arrows as well as the NEXT button to change the time to 8:00 AM.

Understanding the Screen

-Swt Delay- is used if the switch in the associated Area is to function as a Timed Off switch. This is the amount of time the lights will stay On after a button press, and before they will turn Off.

-Occ Delay- This is the amount of time the lights will stay On after the occupancy sensor does not detect occupancy and before they will turn Off.

-PC Delay- This is the amount of time the lights will stay On after the photocell trigger point is exceeded and before they will turn Off.

- Key On screen button.
- <Add> Label of onscreen entry field
- Name- Button on keypad
- NEXT Screen Name

**Agenda For Schedule: Dimming**

Start Time	Behavior	Day
8:00 AM	Behavior 4	<input checked="" type="checkbox"/> Mon
▶	Add	<input type="checkbox"/> Tue
		<input type="checkbox"/> Wed
		<input type="checkbox"/> Thu
		<input type="checkbox"/> Fri
		<input type="checkbox"/> Sat
		<input type="checkbox"/> Sun

OK Cancel

OK

**Agenda Behavior Transition Detail**

Transition to behavior: Behavior 1

Absolute Time 12:00 PM

Offset N/A N/A N/A

Swt Delay N/A BW Time N/A

Occ Delay N/A BW Delay N/A

PC Delay N/A BW Ovrd N/A

OK Cancel

Next

Next

**Agenda Behavior Transition Detail**

Transition to behavior: Behavior 7

Absolute Time 5:00 PM

Offset N/A N/A N/A

Swt Delay N/A RW Time N/A  
Occ Delay N/A BW Delay N/A  
PC Delay N/A BW Ovrd N/A  
*Ignore this area during this process*

OK Cancel

Next

**Step 1.7**

Navigate to the Add line of the list, in this case the second line. Click OK to advance to the Behavior Transition Detail screen.

Understanding the Screen

*This Agenda only applies to Monday, as shown here. A transition to Behavior 4 will occur Monday at 8:00 AM.*

**Step 1.8**

The Behavior Transition Detail screen is entered at the Behavior selection box. Use the UP or DOWN arrows to choose the desired Behavior. Consultate the Behavior chart in the Manual for descriptions. For this example change to Behavior 7 (OFF).

**Step 1.9**

Use a combination of the UP and DOWN arrows as well as the NEXT button to change the time to 5:00 PM. When complete, use the NEXT button to navigate to the <OK> on screen button.

- Key
- <Add> On screen button.
- Name- Label of onscreen entry field
- NEXT Button on keypad
- Details Screen Name

**Agenda For Schedule: Dimming**

Start Time	Behavior	
8:00 AM	Behavior 4	<input checked="" type="checkbox"/> Mon
5:00 PM	Behavior 7	<input type="checkbox"/> Tue
	Add	<input type="checkbox"/> Wed
		<input type="checkbox"/> Thu
		<input type="checkbox"/> Fri
		<input type="checkbox"/> Sat
		<input type="checkbox"/> Sun

OK Cancel

Next

**Agenda For Schedule: Dimming**

Start Time	Behavior	
8:00 AM	Behavior 4	<input checked="" type="checkbox"/> Mon
5:00 PM	Behavior 7	<input type="checkbox"/> Tue
	Add	<input type="checkbox"/> Wed
		<input type="checkbox"/> Thu
		<input type="checkbox"/> Fri
		<input type="checkbox"/> Sat
		<input type="checkbox"/> Sun

OK Cancel

Next  
OK

**Agenda For Schedule: Dimming**

Start Time	Behavior	
8:00 AM	Behavior 4	<input checked="" type="checkbox"/> Mon
5:00 PM	Behavior 7	<input checked="" type="checkbox"/> Tue
	Add	<input checked="" type="checkbox"/> Wed
		<input checked="" type="checkbox"/> Thu
		<input checked="" type="checkbox"/> Fri
		<input checked="" type="checkbox"/> Sat
		<input checked="" type="checkbox"/> Sun

OK Cancel

**Step 1.10**

To apply this Agenda or pattern of Behavior to each day of the week press Next to advance to the Day column.

Understanding the Screen

*This Agenda only applies to Monday, as shown here.  
A transition to Behavior 4 will occur Monday at 8:00 AM.  
A transition to Behavior 7 will occur Monday at 5:00 PM.*

**Step 1.11**

Press Next to the -Tuesday- check box.  
Press -OK- to check the box, this will add Tuesday to the active list.

Repeat this button press combination to fill all check boxes (Mon thru Sun)

**Step 1.12**

Use a combination of the NEXT and OK to fill in the Tuesday through Sunday check boxes.

Understanding the Screen

*This Agenda only applies to Monday through Sunday.  
A transition to Behavior 4 will occur each day at 8:00 AM.  
A transition to Behavior 7 will occur each day at 5:00 PM.*

- Key On screen button.
- <Add> Label of onscreen entry field
- Name- Button on keypad
- NEXT Screen Name
- Details

**Step 1.13**

To save the Schedule, press the NEXT button on the navigation keypad to advance to the <Save> button.

Understanding the Screen

The label value of "MTWTFSS -" on the <Monday> through <Sunday> indicates that the same Agenda applies to each of these days.

There are no Exception Calendars associated with this Schedule.

This Schedule has not been assigned to any Areas.

**Step 1.14**

There is only one Schedule available in the system for the dimming pattern of behavior.

To navigate to the Home screen press the HOME button.

Other Options

To modify an existing Schedule, highlight the appropriate Schedule on the list. Navigate to <Edit> and press OK, to initiate the modification of the selected Schedule.

To delete an existing Schedule, highlight the appropriate Schedule on the list. Navigate to <Delete> and press OK, to erase the selected Schedule.

To adjust the system clock, navigate to <Clock> and press OK.



- Key
- <Add> On screen button.
- Name- Label of onscreen entry field
- NEXT Button on keypad
- Details Screen Name

**Step 2: Configure Devices**

The GreenMAX can be configured to handle a wide variety of input devices. These devices operate at +24vdc and are wired to an input terminal on the Low Voltage (AI) board. Each terminal port must be configured to match the device and its expected functionality.

The following Low Voltage input devices can be connected to the system:

- Occupancy sensors.
- Photocells.
- Switches.
- Contact closures.

**Step 2.1**

The configuration steps of the Low Voltage Input Card is performed in the <Config> section of the HDU software.

Understanding the Screen

There are three sections of the HDU software. The other two sections under the buttons are:

- <Monitor> - Used to check the system time, relay status
- <Control> - Access Scheduling

**Step 2.2**

Use a combination of the UP and DOWN arrows as well as the NEXT button to navigate to the <Inputs> onscreen button. Press OK to select.

**Step 2.3**

The **Inputs** listing shows a Digital Switch at LumaCan ID 4. This is a 4 button Digital Switch to be used for Dimming control. Highlight the device and move the indicator to the appropriate device line. Use the UP and DOWN arrows to move about the list. Use NEXT to navigate to the <Edit> button.

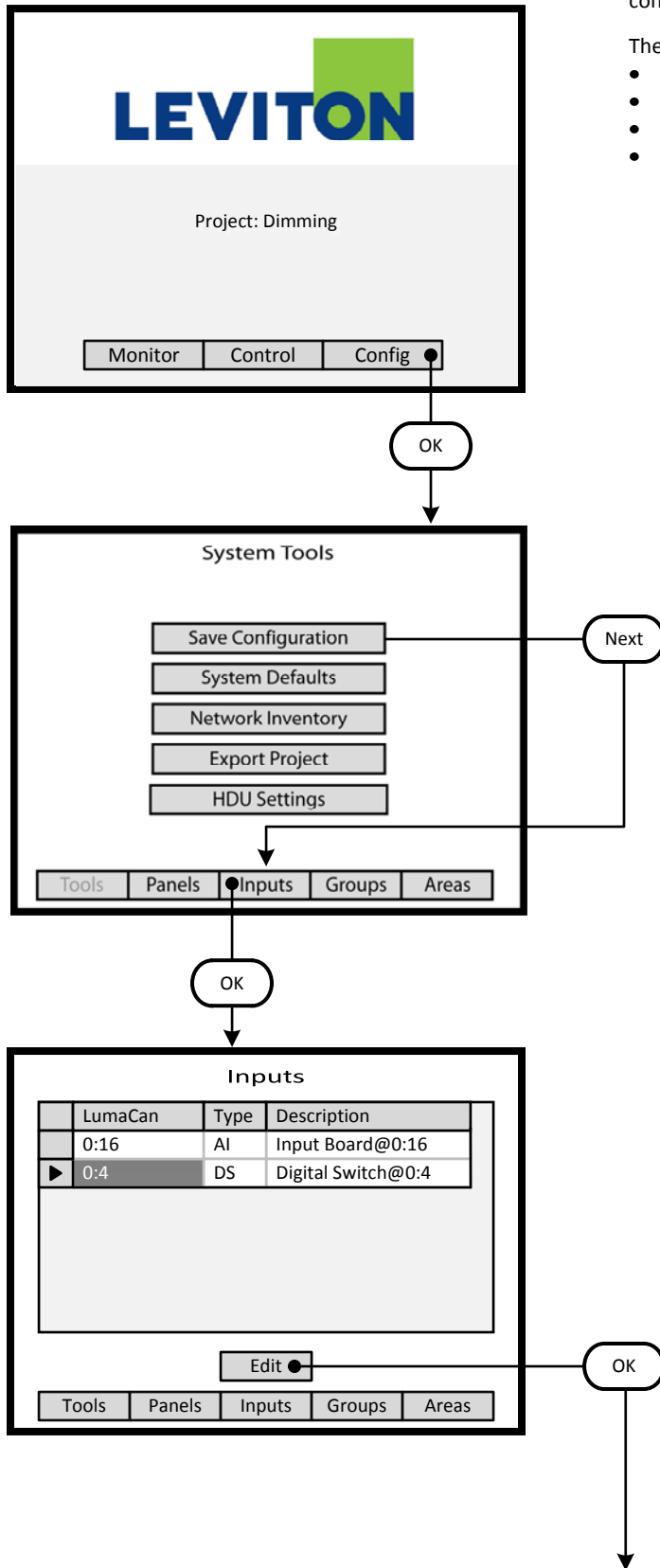

- Key On screen button.
- <Add> Label of onscreen entry field
- Name- Button on keypad
- NEXT Button on keypad
- Details Screen Name

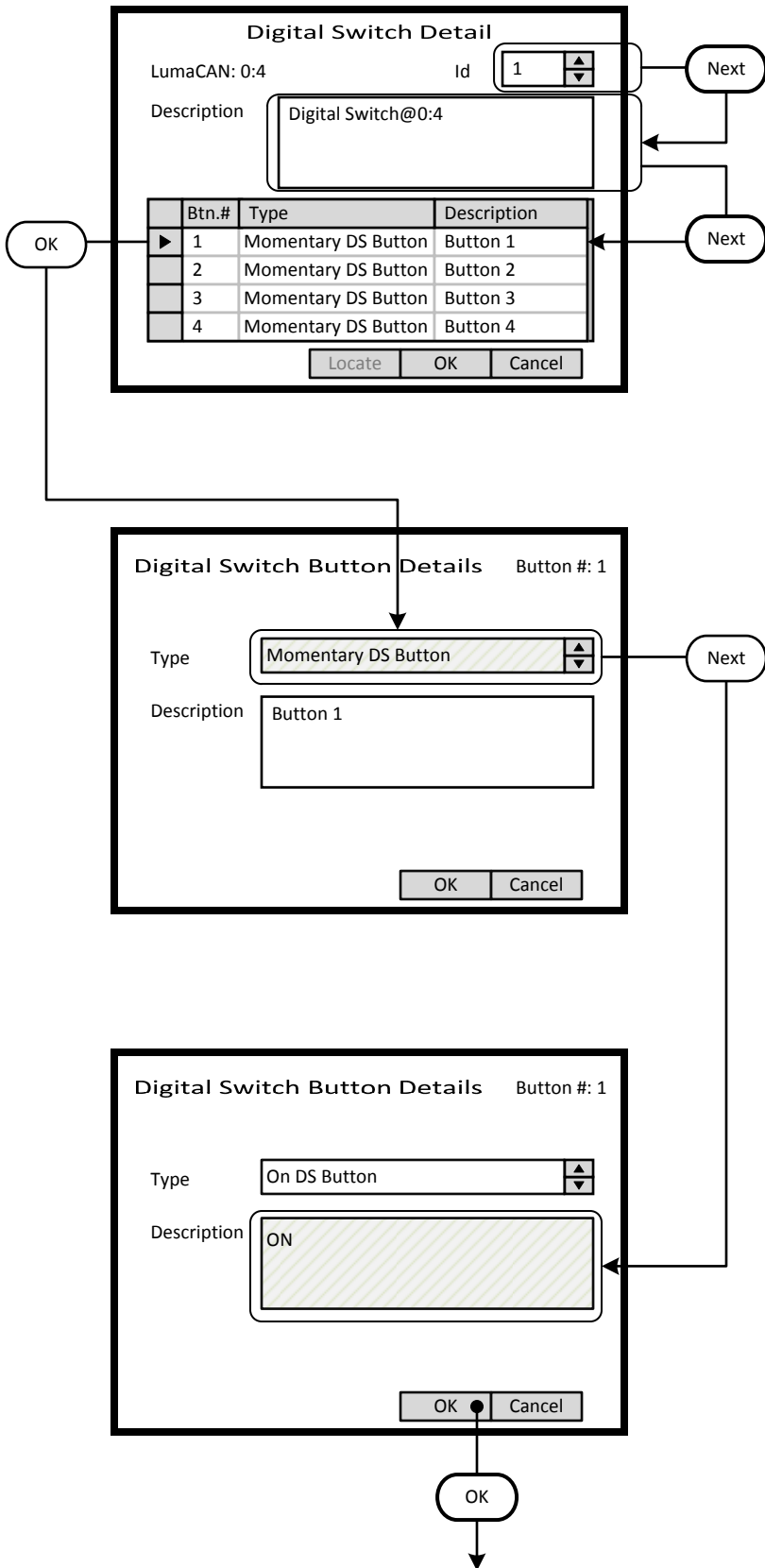

**Step 2.4**

The **Digital Switch Detail** screen provides an ID setting for informational purposes. This can match the switch number on the building floor plan. For this exercise this will be set to 12.

A switch **-Description-** field is provided that can be filled with a maximum of 25 characters of information.

Button function must be configured. Highlight the Button number and press OK to enter the editing screen. These fields fill the list on the previous screen.

Use the UP or DOWN arrows on the keypad to navigate up or down the list.

**Step 2.5**

The Digital Switch Button Details screen is used to configure the individual button function and to name the button. Use the UP and DOWN arrows on the keypad to display the desired button function.

The Description field should be used to document the function of the individual buttons. This field is for user reference only.

Understanding the Screen

- The type options are:
- Momentary DS Button
  - On DS Button
  - Bright DS Button
  - Dim DS Button
  - Off DS Button



- Key
- <Add> On screen button.
- Name- Label of onscreen entry field
- NEXT Button on keypad
- Details Screen Name

**Digital Switch Detail**

LumaCAN: 0:4                      Id

Description

Btn.#	Type	Description
▶ 1	On DS Button	On
2	Bright DS Button	Bright Btn
3	Dim DS Button	Dim Btn
4	Off DS Button	Off

OK

**Inputs**

	LumaCan	Type	Description
	0:16	AI	Input Board@0:16
▶	0:4	DS	Dimming 1

Next

**Inputs**

	LumaCan	Type	Description
	0:16	AI	Input Board@0:16
▶	0:4	DS	Dimming 1

OK

**Step 2.6**

This illustration shows the recommended configuration for a Digital Switch used for dimming control application. The button Type fields should match those shown. Each field should be adjusted individually. Button descriptions are entered on the Button Detail Screen shown previous.

Use the UP or DOWN arrows on the keypad to navigate up or down the list.

Use NEXT and BACK to navigate between sections on the screen.

Understanding the Screen

The ID number are for information purposes and can be used to match assigned project switch numbers.

**Step 2.7**

The Inputs list has a Digital Switch at ID 4 and is described as Dimming 1.

Use the UP and DOWN arrows to move about the list. Use NEXT to navigate to the <Areas> button.

**Step 2.8**

The Inputs list has an Low Voltage Input Board (AI) at LumaCan ID 16 and a Digital Switch (DS) at LumaCan ID 4 that is described as Dimming 1.

Use NEXT to navigate to the <Areas> button. Press OK to advance to the Areas maintenance screen.

- Key
- <Add> On screen button.
- Name- Label of onscreen entry field
- NEXT Button on keypad
- Details Screen Name

**Step 3: Create an Area**

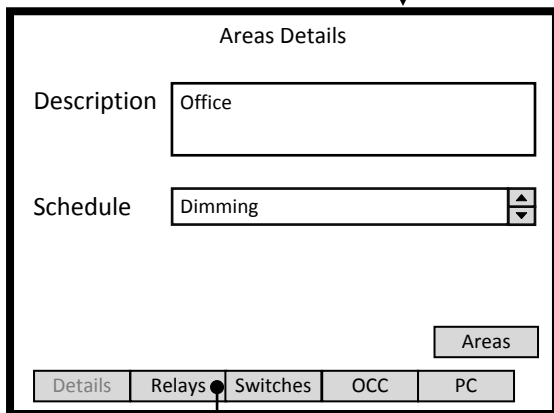
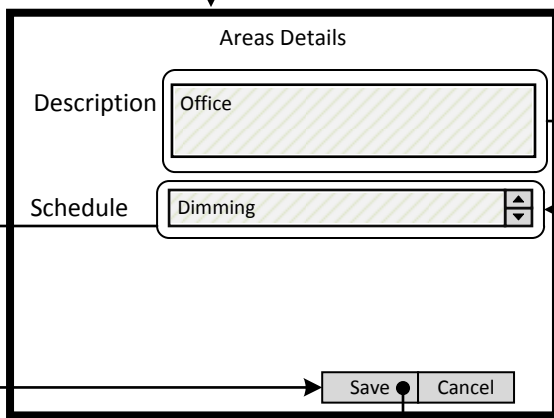
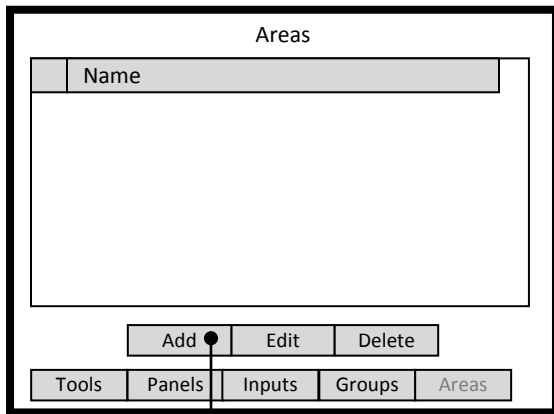

**Step 3.1**

The **Areas** screen lists all the current Areas available in the system. At this step there are no existing Areas. To create a new Area navigate to the <Add> onscreen button and press OK.

Understanding the Screen

There are no Areas in this system.

Description of the onscreen buttons:

- <Edit> selecting this onscreen button will allow editing of the highlighted Area in the list.
- <Delete> selecting this onscreen button will permanently remove the highlighted Area from the list.
- <Tools> use to navigate to the System Tools screen.
- <Panels> use to navigate to the Relay Panel Detail Screen
- <Groups> use to navigate to the Group building screen
- <Areas> use to navigate to the Areas configuration screen

**Step 3.2**

Enter the desired Area name and detail in the -Description- field. Enter as much information as practical. The Area must be assigned to a Schedule. An area can only be assigned to one schedule at a time. All of the available system Schedules will appear in the -Schedule- list box.

Understanding the Screen

To appear in the -Schedule- list box, Schedules must be created prior to entering this screen. See the "Create a Schedule" section.

Description of the onscreen buttons:

- <Save> selecting this onscreen button will create the Area, save it, and add advance to the next screen
- <Cancel> used to discard entries

**Step 3.3**

The newly created Area will contain relays and associated control devices. Additional navigation buttons are available to navigate to screens that populate or edit the contents of the Area. To add relays to the Area, navigate to the <Relay> onscreen button and press OK.

Understanding the Screen

Description of the onscreen buttons:

- <Areas> use to navigate to the Areas list screen
- <Relays> selecting this onscreen button will allow the addition/editing of assigned relays
- <Switches> selecting this onscreen button to add/edit assigned switches
- <OCC> selecting this onscreen button to add/edit assigned Occupancy Sensors
- <PC> selecting this onscreen button to add/edit assigned Photocells

- Key
- <Add> On screen button.
- Name- Label of onscreen entry field
- NEXT Button on keypad
- Details Screen Name

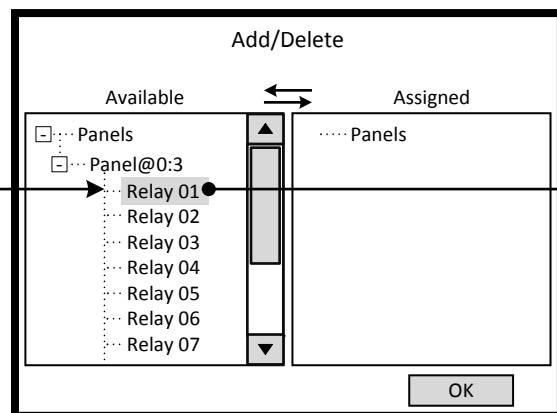
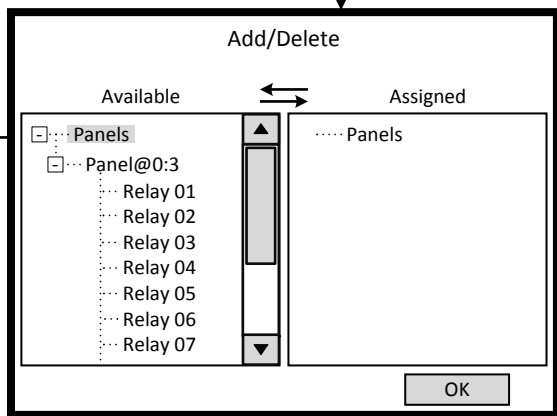
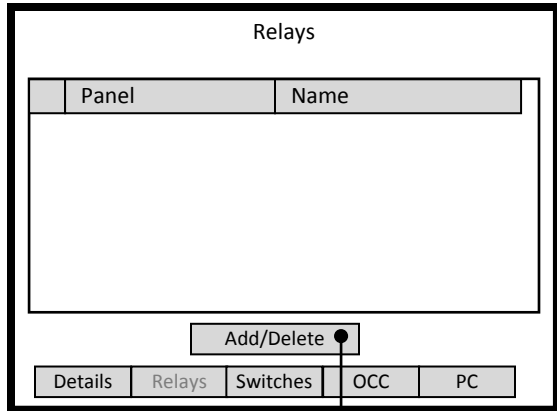

**Step 3.4**

The **Relays** screen lists all the current relays assigned to the Area. To add a new relay to the Area navigate to the <Add/Delete> onscreen button and press OK.

Understanding the Screen

There are currently no relays assigned to the Area.

Description of the onscreen buttons:

- <Details> use to navigate to the **Area Details** screen
- <Switches> selecting this onscreen button to add/edit assigned switches
- <OCC> selecting this onscreen button to add/edit assigned Occupancy Sensors
- <PC> selecting this onscreen button to add/edit assigned Photocells

**Step 3.5**

The left side of the screen under the heading **-Available-** lists all of the relays that have not been assigned to an Area. If the desired relay is not on this list it has been assigned to another Area. Relays are displayed according to the panel they are installed in. All unassigned relays in the system can be seen on this list.

Understanding the Screen

Complete panels may be collapsed by highlighting name on the list pressing OK.

Description of the onscreen button:

- <OK> selecting this onscreen button will save the selections made and return to the **Relays** list screen.

**Step 3.6**

Relays are added to the Area by moving them from the **-Available-** list to the **-Assigned-** list. This is accomplished by highlighting the desired relay on the left side of the screen and using the right arrow to move it to the right side of the screen.

Understanding the Screen

Currently there are no relays assigned to this Area. Relays 01 through 07 are available for assignment. Relay 01 of Panel 3 has been selected as a candidate for assignment to the Area.

- Key
- <Add> On screen button.
- Name- Label of onscreen entry field
- NEXT Button on keypad
- Details Screen Name

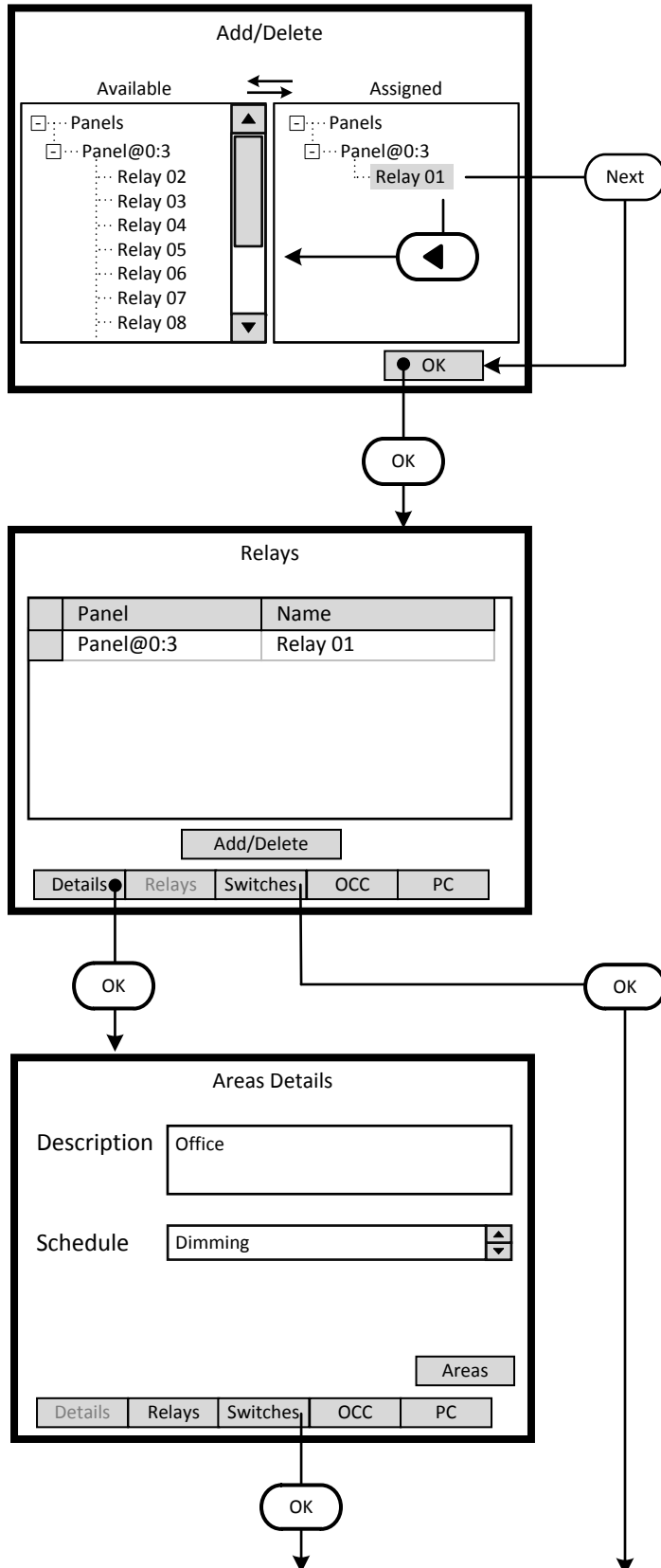

**Step 3.7**

Relays are deleted from the Area by moving them from the **-Assigned-** list to the **-Available-** list. This is accomplished by highlighting the desired relay on the right side of the screen and using the left arrow to move it to the right side of the screen. To accept the assignment, navigate to the **-OK-** onscreen button and press OK or Enter.

Understanding the Screen

Currently Relay 01 of Panel 3 has been assignment to the Area.  
Relays 02 through 07 are available for assignment.

**Step 3.8**

The **-Relays-** screen lists the relays assigned to the Area. This list will be displayed each time this section of the Area information is entered. The next common step is to add switch buttons to the Area.

Understanding the Screen

Currently only Relay 01 of Panel 3 has been assignment to the Area.  
There are two navigating paths to the next screen. Using the **<Switches>** onscreen button skips a screen and goes directly to the **-Switches-** screen.

Description of the onscreen buttons:

- <Details> use to navigate to the **-Area Details-** screen
- <Switches> use to navigate to the **-Switches-** screen
- <OCC> use to navigate to the **-Occupancy Sensors-** screen
- <PC> use to navigate to the **-Photocells-** screen

- Key On screen button.
- <Add> Label of onscreen entry field
- Name- Button on keypad
- NEXT Screen Name
- Details Screen Name

**Step 4: Switch Buttons**

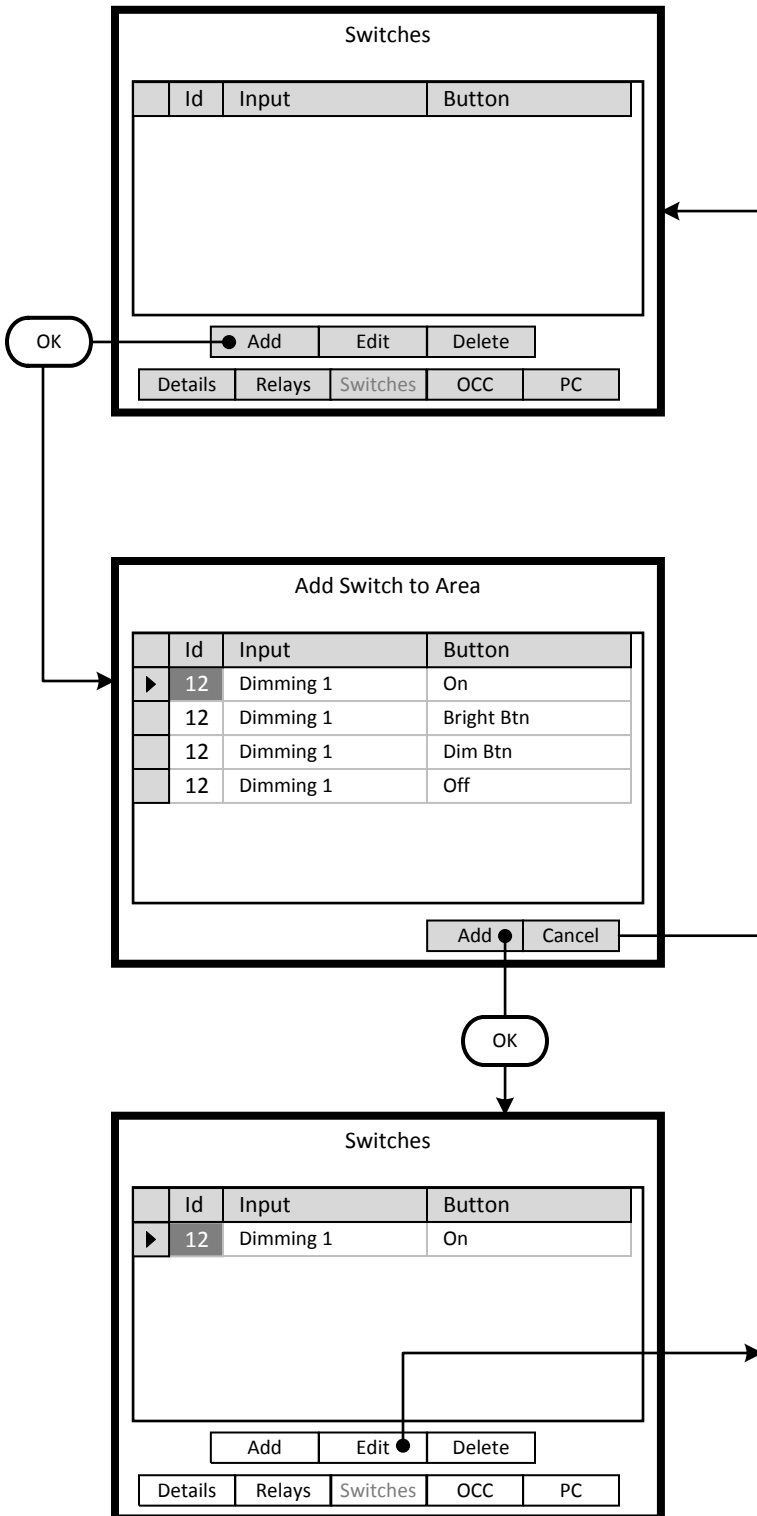

**Step 4.1**

The **-Switches-** screen lists the switch buttons assigned to the Area. This list will be displayed each time this section of the Area information is entered. The next common step is to add switch buttons to the Area.

Understanding the Screen

Currently there are no switch buttons assigned to the Area.

Description of the onscreen buttons:

- <Details> use to navigate to the **-Area Details-** screen
- <Relays> use to navigate to the **-Relays-** screen
- <OCC> use to navigate to the **-Occupancy Sensors-** screen
- <PC> use to navigate to the **-Photocells-** screen

**Step 4.2**

The **-Add Switch to Area-** screen lists the available and unassigned switch buttons for the system. As a switch button is assigned to an Area, it is removed from this list.

Understanding the Screen

The highlighted button, button 1 of the switch at LumaCan address 4 can be added to the Area by selecting the **<Add>** onscreen button.

Description of the onscreen buttons:

- <Cancel> use to navigate to the **-Area Details-** screen

**Step 4.3**

The **-Switches-** screen lists the switch buttons assigned to the Area. This list will be displayed each time this section of the Area information is entered.

Understanding the Screen

Currently button 1 of the switch at LumaCan address 4 is assigned to the Area.

Description of the onscreen buttons:

- <Add> use to navigate to the **-Add Switch to Area-** screen
- <Delete> use to delete the highlighted button
- <Details> use to navigate to the **-Area Details-** screen
- <Relays> use to navigate to the **-Relays-** screen
- <OCC> use to navigate to the **-Occupancy Sensors-** screen
- <PC> use to navigate to the **-Photocells-** screen

- Key On screen button.
- <Add> Label of onscreen entry field
- Name- Button on keypad
- NEXT Screen Name

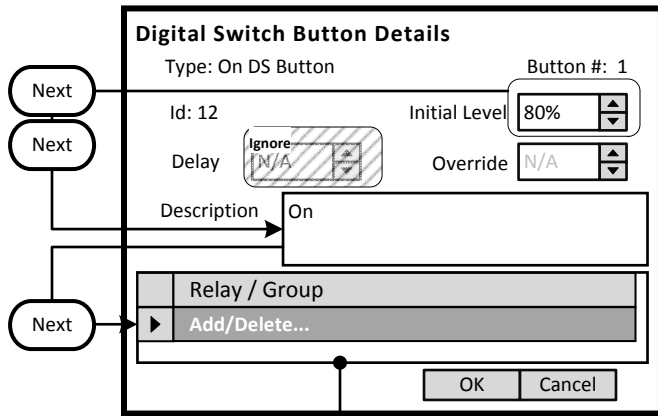

OK

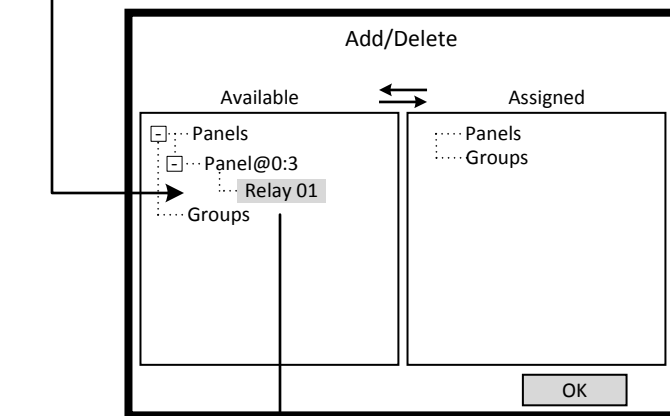
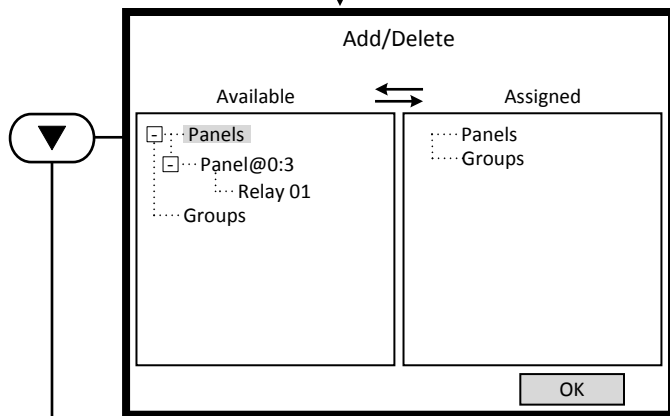

Next

**Step 4.4**

This screen configures the characteristics of the switch button. Enter the value for On in the **-Initial Level-** field, this exercise requires 80%. The **-Relay / Group-** list will be populated with the corresponding controlled relays or groups.

Understanding the Screen

The **-Description-** field can be edited on this screen. Information from the **Digital Switch Detail** screen will be displayed here.

Ignore the settings of **-Delay-** and **-Override-**.

Description of the onscreen buttons:

<OK> save the selections made and return to the **Switches** list screen.

<Cancel> use to discard entries and return to previous screen

**Step 4.5**

The left side of the screen under the heading **-Available-** lists all of the relays that have been assigned to an Area. If the desired relay is not on this list it has not been assigned to this Area. Relays are displayed according to the panel they are installed in. Use the navigation keypad to highlight the desired relay.

Understanding the Screen

Complete panels may be collapsed by highlighting name on the list pressing OK.

Description of the onscreen button:

<OK> selecting this onscreen button will save the selections made and return to the **Relays** list screen.

**Step 4.6**

Relays are assigned to the Switch button by moving them from the **-Available-** list to the **-Assigned-** list. This is accomplished by highlighting the desired relay on the left side of the screen and using the right arrow to move it to the right side of the screen.

Understanding the Screen

Currently there are no relays assigned to this Switch Button. Relay 01 of Panel 3 has been selected as a candidate for assignment to the Switch Button.

- Key On screen button.
- <Add> Label of onscreen entry field
- Name- Button on keypad
- NEXT Button on keypad
- Details Screen Name

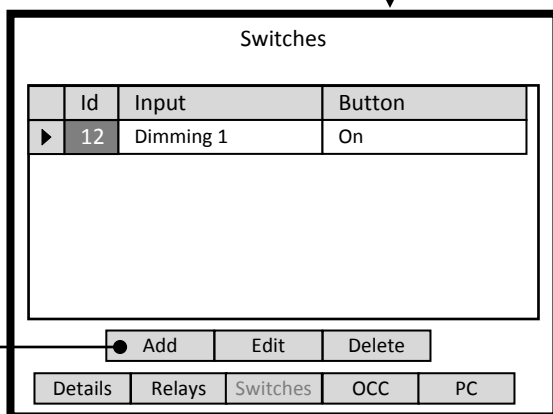
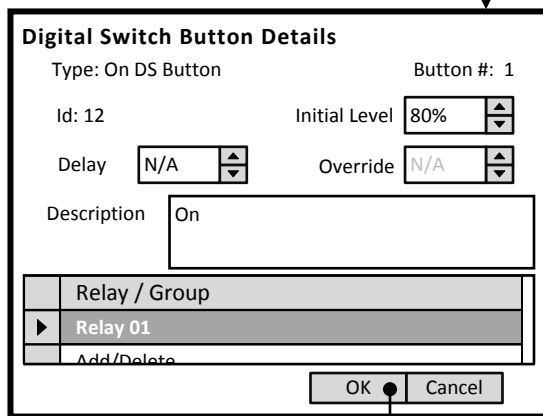
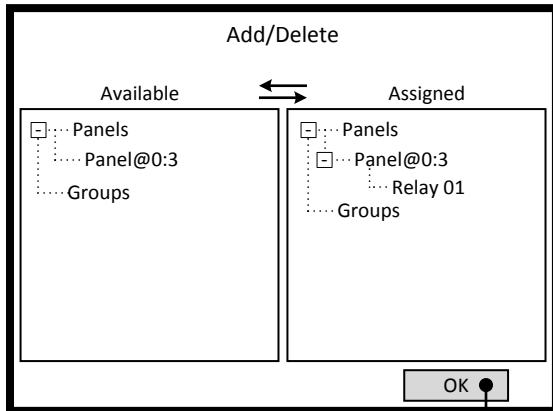

**Step 4.7**

Relay 01 is assigned to the control of the Switch Button. To remove it, highlight the relay in the **-Assigned-** list and press the Left arrow button of the navigation keypad. The relay will move back to the **-Available-** list on the left side of the screen.

Understanding the Screen

Relay 01 of Panel 3 has is assigned to the Switch Button. No other relays are currently available in the Area.

Description of the onscreen buttons:

<OK> use to accept entries and navigate to the **-Digital Switch Button Details-** screen

**Step 4.8**

Relay 01 is assigned to the control of the Switch Button 1. To remove it, highlight the relay in the **-Assigned-** list and press the Left arrow button of the navigation keypad. The relay will move back to the **-Available-** list on the left side of the screen.

Understanding the Screen

Relay 01 of Panel 3 has is assigned to the Switch Button. Relay 01 of Panel 3 will start daylight harvesting when button 1 of switch ID: 12 is pressed. The settings of **-Initial Level-**, **-Delay-** and **-Override-** do not apply.

Description of the onscreen buttons:

- <OK> use to accept entries and navigate to the **-Switches-** screen
- <Cancel> use to abandon entries and navigate to the **-Switches-** screen

**Step 4.9**

All four of the Buttons for the Switch must be assigned to the Area. This summary list will be displayed each time this section of the Area information is entered. Navigate to the <Add> button and press OK button on the keypad.

Understanding the Screen

Currently there is one switch button assigned to the Area. Description of the onscreen buttons:

- <Edit> use to navigate to the **-Digital Switch Button Details-** screen to make modifications to settings of the highlighted button
- <Delete> use to delete the highlighted button from the Area
- <Details> use to navigate to the **-Area Details-** screen
- <Relays> use to navigate to the **-Relays-** screen
- <OCC> use to navigate to the **-Occupancy Sensors-** screen
- <PC> use to navigate to the **-Photocells-** screen

- Key
- <Add> On screen button.
- Name- Label of onscreen entry field
- NEXT Button on keypad
- Details Screen Name

**Add Switch to Area**

	Id	Input	Button
▶	12	Dimming 1	Bright Btn
	12	Dimming 1	Dim Btn
	12	Dimming 1	Off

OK

**Switches**

	Id	Input	Button
	12	Dimming 1	On
▶	12	Dimming 1	Bright Btn

Add    Edit    Delete

OK

**Add Switch to Area**

	Id	Input	Button
▶	12	Dimming Zone 1	Dim Btn
	12	Dimming Zone 1	Daylight Off

OK

**Step 4.10**

The **-Add Switch to Area-** screen lists the available and unassigned switch buttons for the system. As a switch button is assigned to an Area, it is removed from this list.

Understanding the Screen

The highlighted button, Bright Btn button of the switch ID 12 at LumaCan address 4 can be added to the Area by selecting the **<Add>** onscreen button.

Description of the onscreen buttons:

**<Cancel>**      use to navigate to the **-Area Details-** screen

**Step 4.11**

The **-Switches-** screen lists the switch buttons assigned to the Area. This summary list will be increase as each button is added.

Understanding the Screen

Currently 2 buttons are assigned; On, Bright Btn of switch ID 12 at LumaCan address 4.

Description of the onscreen buttons:

**<Add>**      use to navigate to the **-Add Switch to Area-** screen

**<Delete>**    use to delete the highlighted button

**<Details>**   use to navigate to the **-Area Details-** screen

**<Relays>**    use to navigate to the **-Relays-** screen

**<OCC>**        use to navigate to the **-Occupancy Sensors-** screen

**<PC>**         use to navigate to the **-Photocells-** screen

**Step 4.12**

Continue to add all of the relevant buttons to the Area.

Understanding the Screen

The highlighted button, Dim Btn button of the switch ID 12 at LumaCan address 4 can be added to the Area by selecting the **<Add>** onscreen button.

Description of the onscreen buttons:

**<Cancel>**      use to navigate to the **-Area Details-** screen



- Key On screen button.
- <Add> Label of onscreen entry field
- Name- Button on keypad
- NEXT Screen Name
- Details

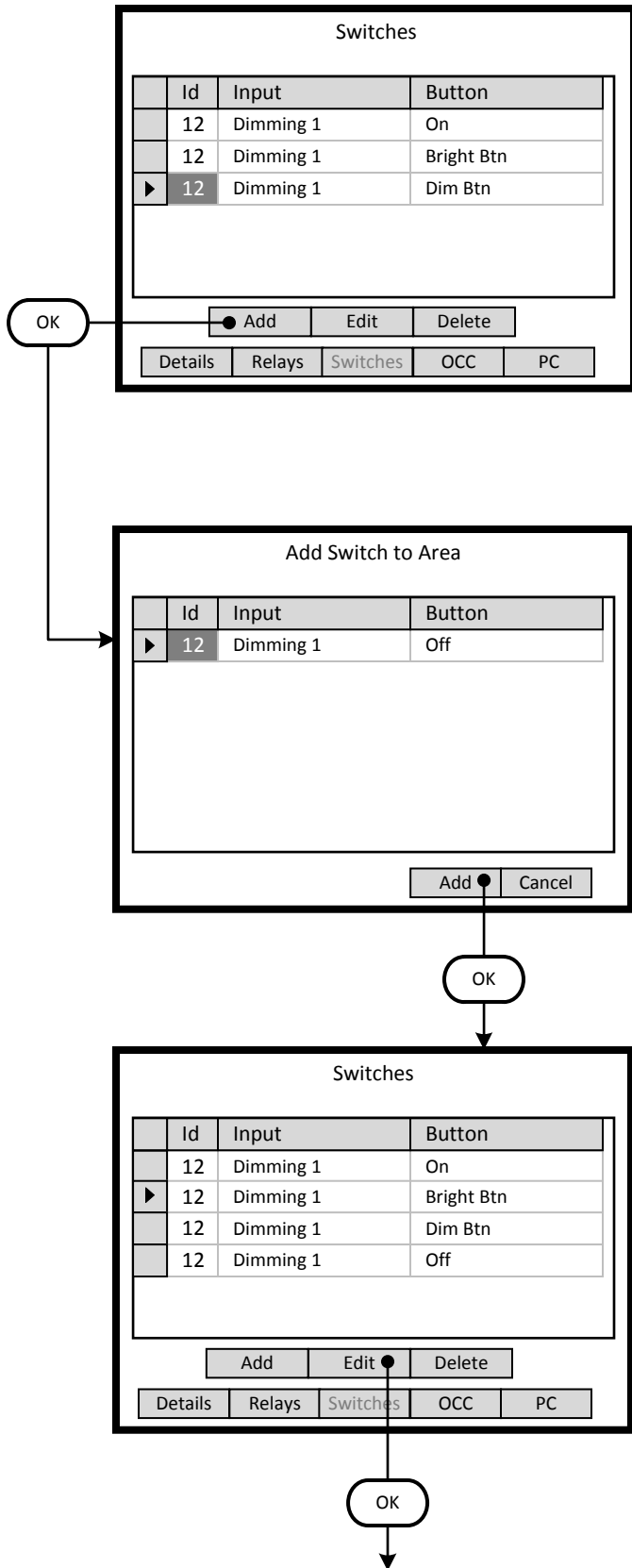

**Step 4.13**

The **-Switches-** screen lists the switch buttons assigned to the Area. This summary list will increase as each button is added.

Understanding the Screen

Currently 3 buttons are assigned; On, Bright Btn, Dim Btn of switch ID 12 at LumaCan address 4.

Description of the onscreen buttons:

- <Add> use to navigate to the **-Add Switch to Area-** screen
- <Delete> use to delete the highlighted button
- <Details> use to navigate to the **-Area Details-** screen
- <Relays> use to navigate to the **-Relays-** screen
- <OCC> use to navigate to the **-Occupancy Sensors-** screen
- <PC> use to navigate to the **-Photocells-** screen

**Step 4.14**

Continue to add all of the relevant buttons to the Area.

Understanding the Screen

The highlighted button, Off button of the switch ID 12 at LumaCan address 4 can be added to the Area by selecting the <Add> onscreen button.

Description of the onscreen buttons:

- <Cancel> use to navigate to the **-Area Details-** screen

**Step 4.15**

All four of the buttons for the switch have been added to the Area. Each of the buttons must be assigned to the relay to be controlled. The On button was previously configured in Step 4.4. Navigate to the <Edit> button and press OK button on the keypad to configure each button of the remaining three buttons.

Understanding the Screen

Currently there is one switch button assigned to the Area.

Description of the onscreen buttons:

- <Delete> use to delete the highlighted button from the Area
- <Details> use to navigate to the **-Area Details-** screen
- <Relays> use to navigate to the **-Relays-** screen
- <OCC> use to navigate to the **-Occupancy Sensors-** screen
- <PC> use to navigate to the **-Photocells-** screen

- Key
- <Add> On screen button.
- Name- Label of onscreen entry field
- NEXT Button on keypad
- Details Screen Name

Switches			
	Id	Input	Button
	12	Dimming 1	On
	12	Dimming 1	Bright Btn
	12	Dimming 1	Dim Btn
	12	Dimming 1	Off

Add Edit Delete

Details Relays Switches OCC PC

OK

**Digital Switch Button Details**

Type: Bright DS Button

Id: 12

Delay: N/A

Description: Bright Btn

Button #: 2

Ignore: 150%

Initial Level: 150%

Override: N/A

Relay / Group
Add/Delete...

OK Cancel

Next  
Next  
Next  
Next

OK

**Add/Delete**

Available

- Panel@0:3
- Relay 01

Assigned

- Relay 01

OK

OK

**Step 4.16**

The three new buttons listed on the **-Switches-** screen require configuration. Highlight the desired button and navigate to the **<Edit>** onscreen button.

Understanding the Screen

Currently all buttons of the switch at LumaCan address 4 are assigned to the Area.

Description of the onscreen buttons:

- <Add> use to navigate to the **-Add Switch to Area-** screen
- <Delete> use to delete the highlighted button
- <Details> use to navigate to the **-Area Details-** screen
- <Relays> use to navigate to the **-Relays-** screen
- <OCC> use to navigate to the **-Occupancy Sensors-** screen
- <PC> use to navigate to the **-Photocells-** screen

**Step 4.17**

The Bright DS button will temporarily increase the light level from the Target Level of the photocell. The **-Relay / Group-** list will be populated with the corresponding controlled relays or groups.

Understanding the Screen

Ignore the settings of **-Initial Level-**, **-Delay-**, and **-Override-**.

- Description of the onscreen buttons:
- <OK> save the selections made and return to the **Switches** list screen.
  - <Cancel> use to discard entries and return to previous screen

**Step 4.18**

Use the instructions outlined in Steps 4.5 through 4.7 to assign Relay 01 to the control of the Switch Button.

To remove it, highlight the relay in the **-Assigned-** list and press the Left arrow button of the navigation keypad. The relay will move back to the **-Available-** list on the left side of the screen.

Understanding the Screen

Relay 01 of Panel 3 has is assigned to the Switch Button. No other relays are currently available in the Area.

Description of the onscreen buttons:

- <OK> use to accept entries and navigate to the **-Digital Switch Button Details-** screen

- Key On screen button.
- <Add> Label of onscreen entry field
- Name- Button on keypad
- NEXT Screen Name

Switches			
	Id	Input	Button
	12	Dimming 1	On
	12	Dimming 1	Bright Btn
	12	Dimming 1	Dim Btn
	12	Dimming 1	Off

Add Edit Delete

Details Relays Switches OCC PC

OK

**Digital Switch Button Details**

Type: Dim DS Button

Id: 12

Delay: Ignore / N/A

Initial Level: Ignore / 50%

Override: Ignore / N/A

Button #: 3

Description: Dim Btn

Relay / Group
▶ Add/Delete...

OK Cancel

Next

Next

Next

Next

OK

**Add/Delete**

Available

- ▶ Panels
- Panel@0:3
- Groups

Assigned

- ▶ Panels
- Panel@0:3
- Relay 01
- Groups

←→

OK

OK

**Step 4.19**

Configure the next button listed on the **-Switches-** screen. Highlight the desired button and navigate to the **<Edit>** onscreen button.

Understanding the Screen

Currently all buttons of the switch at LumaCan address 4 are assigned to the Area.

Description of the onscreen buttons:

- <Add> use to navigate to the **-Add Switch to Area-** screen
- <Delete> use to delete the highlighted button
- <Details> use to navigate to the **-Area Details-** screen
- <Relays> use to navigate to the **-Relays-** screen
- <OCC> use to navigate to the **-Occupancy Sensors-** screen
- <PC> use to navigate to the **-Photocells-** screen

**Step 4.20**

The Bright DS button will temporarily decrease the light level from the Target Level of the photocell. The **-Relay / Group-** list will be populated with the corresponding controlled relays or groups.

Understanding the Screen

Ignore the settings of **-Initial Level-**, **-Delay-**, and **-Override-**. Description of the onscreen buttons:

- <OK> save the selections made and return to the **Switches** list screen.
- <Cancel> use to discard entries and return to previous screen

**Step 4.21**

Use the instructions outlined in Steps 4.5 through 4.7 to assign Relay 01 to the control of the Switch Button. To remove it, highlight the relay in the **-Assigned-** list and press the Left arrow button of the navigation keypad. The relay will move back to the **-Available-** list on the left side of the screen.

Understanding the Screen

Relay 01 of Panel 3 has is assigned to the Switch Button. No other relays are currently available in the Area.

Description of the onscreen buttons:

- <OK> use to accept entries and navigate to the **-Digital Switch Button Details-** screen

- Key On screen button.
- <Add> Label of onscreen entry field
- Name- Button on keypad
- NEXT Screen Name

Switches

	Id	Input	Button
	12	Dimming 1	On
▶	12	Dimming 1	Bright Btn
	12	Dimming 1	Dim Btn
	12	Dimming 1	Off

OK

**Digital Switch Button Details**

Type: Off DS Button

Id: 12

Delay:

Initial Level:

Button #: 4

Ignore Override:

Description: Off

Relay / Group
▶ Add/Delete...

OK

Add/Delete

Available	Assigned
<input type="checkbox"/> Panels <input type="checkbox"/> Panel@0:3 <input type="checkbox"/> Groups	<input type="checkbox"/> Panels <input checked="" type="checkbox"/> Panel@0:3 <input type="checkbox"/> Relay 01 <input type="checkbox"/> Groups

**Step 4.22**

The three new buttons listed on the **-Switches-** screen require configuration. Highlight the desired button and navigate to the **<Edit>** onscreen button.

Understanding the Screen

Currently all buttons of the switch at LumaCan address 4 are assigned to the Area.

Description of the onscreen buttons:

- <Add> use to navigate to the **-Add Switch to Area-** screen
- <Delete> use to delete the highlighted button
- <Details> use to navigate to the **-Area Details-** screen
- <Relays> use to navigate to the **-Relays-** screen
- <OCC> use to navigate to the **-Occupancy Sensors-** screen
- <PC> use to navigate to the **-Photocells-** screen

**Step 4.23**

The Off DS button will turn Off the zone. The light level will dim to zero output and turn off the relay. The **-Relay / Group-** list will be populated with the corresponding controlled relays or groups.

Understanding the Screen

Ignore the settings of **-Delay-** and **-Override-**.

Description of the onscreen buttons:

- <OK> save the selections made and return to the **Switches** list screen.
- <Cancel> use to discard entries and return to previous screen

**Step 4.24**

Use the instructions outlined in Steps 4.5 through 4.7 to assign Relay 01 to the control of the Switch Button.

To remove it, highlight the relay in the **-Assigned-** list and press the Left arrow button of the navigation keypad. The relay will move back to the **-Available-** list on the left side of the screen.

Understanding the Screen

Relay 01 of Panel 3 has is assigned to the Switch Button. No other relays are currently available in the Area.

Description of the onscreen buttons:

- <OK> use to accept entries and navigate to the **-Digital Switch Button Details-** screen

**B10 Daylight Harvesting - Programming Overview**

This section will present the typical steps required to program a GreenMAX system to provide Dimming functionality.

The fundamental components required for Dimming control are:

- GreenMAX Dimming and Switching Relay Modules – RELAY-1DS
- Low Voltage Photocell – 24VDC with analogue 0 to 10VDC output range - mandatory
- Low Voltage Occupancy Sensor – 24VDC with On/Off signal output – optional
- 4 Button Switch - either Low Voltage or Digital

**Office Dimming Schedule****Monday to Sunday**

8:00am Office Dimming

B10

Lights will be controlled by their respective devices:

Occupancy Sensors – 10 minute delay

Photocells – 35 foot-candle initial target value – 10 minute delay

Switch Buttons (4): On Button – starts Daylight Harvesting

Bright Button – with Over-ride time

Dim Button – with Over-ride time

Off Button – fades lights to OFF

5:00pm OFF sweep

B7

Lights will be turned OFF

**Programming Checklist**

- Create a schedule.
- Configure Low Voltage inputs as required.  
(occupancy sensors, photocells, low voltage switches)
- Configure switch buttons. (On/Bright/Dim/Off)
- Create an Area.
- Assign a schedule to an Area.
- Add relays to Area.
- Add switch buttons to area.
- Assign relays to switch buttons
- Add occupancy sensor to Area.
- Assign relays to occupancy sensor.
- Add photocell to area.
- Assign relays to the photocell.

- Key On screen button.
- <Add> Label of onscreen entry field
- Name- Button on keypad
- NEXT Button on keypad
- Details Screen Name

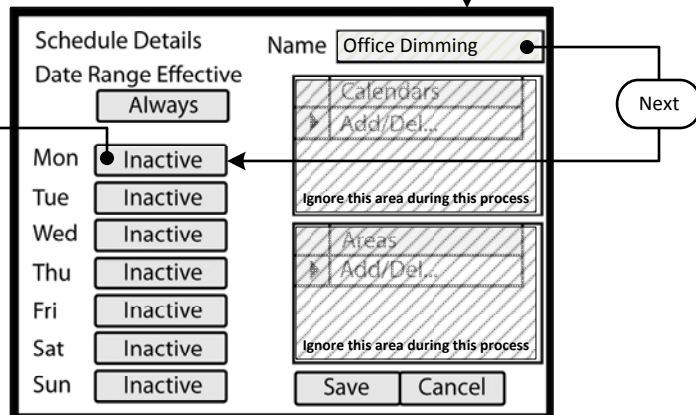
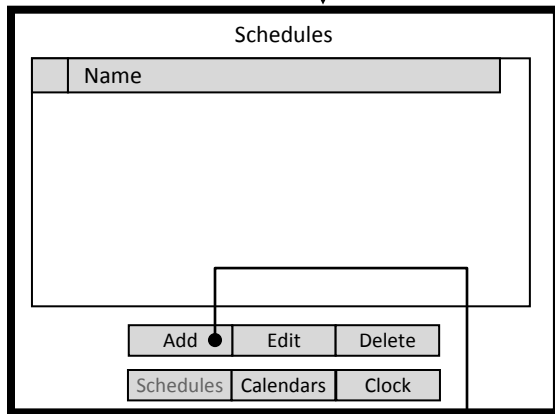

**Step 1: Create a Schedule**

Programming operation of the GreenMAX is based on running Schedules. A Schedule can be considered a default seven (7) day pattern of operation.

The following rules apply:

- An Area requires a Schedule to operate.
- Only one Schedule can be assigned to an Area.
- A Schedule can be assigned to multiple Areas.
- Schedules reside in the GreenMAX system and can be accessed through the Handheld Display Unit (HDU).

**Step 1.1**

To create a Schedule, enter the <Control> section of the Handheld Display Unit (HDU) software.

Understanding the Screen

There are three sections of the HDU software. The sections under the buttons are:

- <Monitor> - Used to check the system time/date, relay status
- <Control> - Access Scheduling
- <Config> - Configuration of system including set-up of Areas

**Step 1.2**

The first <Control> HDU screen lists the existing Schedules available in your GreenMAX System. The screen shown indicates that there are no Schedules available or created.

By navigating to <Add> and pressing OK, this will initiate the creation of a Schedule.

Other Options

To modify an existing Schedule, highlight the appropriate Schedule on the list. Navigate to <Edit> and press OK, to initiate the modification of the selected Schedule.

To delete an existing Schedule, highlight the appropriate Schedule on the list. Navigate to <Delete> and press OK, to erase the selected Schedule.

**Step 1.3**

The screen is entered with the -Name- field highlighted. Enter the desired name of your Schedule using the alpha numeric keypad of the HDU. When complete, press the NEXT button on the navigation keypad. The cursor will advance to the <Monday> button.

Understanding the Screen

The label value of "Inactive" shown on the <Monday> button indicates that there is currently no Behavior transitions programmed for this day. The same is true for all days, Monday through Sunday, of this schedule.

There are no Exception Calendars associated with this Schedule.

This Schedule has not been assigned to any Areas.

- Key
- <Add> On screen button.
- Name- Label of onscreen entry field
- NEXT Button on keypad
- Details Screen Name

**Agenda For Schedule: Office Dimming**

Start Time	Behavior	
	Add	<input checked="" type="checkbox"/> Mon
		<input type="checkbox"/> Tue
		<input type="checkbox"/> Wed
		<input type="checkbox"/> Thu
		<input type="checkbox"/> Fri
		<input type="checkbox"/> Sat
		<input type="checkbox"/> Sun

OK Cancel

OK

**Agenda Behavior Transition Detail**

Transition to behavior: Behavior 1

Absolute Time 12:00 PM

Offset N/A N/A N/A

Swt Delay N/A BW Time N/A

Occ Delay N/A BW Delay N/A

PC Delay N/A BW Ovrld N/A

OK Cancel

Next

Next

**Agenda Behavior Transition Detail**

Transition to behavior: Behavior 10

Absolute Time 8:00 AM

Offset N/A N/A N/A

*Ignore this area during this process*

Swt Delay N/A BW Time N/A

Occ Delay N/A BW Delay N/A

PC Delay N/A BW Ovrld N/A

OK Cancel

Next

**Step 1.4**

The screen is entered at the first line of the Agenda. There are a total of 24 Behavior Transition times available per day. Clicking OK will advance to the Behavior Transition Detail screen.

Understanding the Screen

*This Agenda only applies to Monday, as shown here.*

<OK> - Will save the settings or changes

<Cancel> - Will discard the changes

**Step 1.5**

The Behavior Transition Detail screen is entered at the Behavior selection box. Use the UP or DOWN arrows to choose the desired Behavior. Consultate the Behavior chart in the Manual for descriptions. For this example change to Behavior 10.

Understanding the Screen

<Offset> provides access to Sunrise and Sunset settings for Astronomical clock times.

-BW Time-, -BW Delay-, -BW Ovrld- - These are the Blinkwarn settings that apply to this Behavior Transition only. They will override the Global Blinkwarn Settings set in the System Settings section.

**Step 1.6**

Use a combination of the UP and DOWN arrows as well as the NEXT button to change the time to 8:00 AM.

Understanding the Screen

-Swt Delay- is used if the switch in the associated Area is to function as a Timed Off switch. This is the amount of time the lights will stay On after a button press, and before they will turn Off.

-Occ Delay- This is the amount of time the lights will stay On after the occupancy sensor does not detect occupancy and before they will turn Off.

-PC Delay- This is the amount of time the lights will stay On after the photocell trigger point is exceeded and before they will turn Off.

- Key On screen button.
- <Add> Label of onscreen entry field
- Name- Button on keypad
- NEXT Screen Name

**Agenda For Schedule: Office Dimming**

Start Time	Behavior
8:00 AM	Behavior 10
▶	Add

Mon  
 Tue  
 Wed  
 Thu  
 Fri  
 Sat  
 Sun

OK Cancel

OK

**Agenda Behavior Transition Detail**

Transition to behavior: Behavior 1

Absolute Time 12:00 PM

Offset N/A N/A N/A

Swt Delay N/A BW Time N/A

Occ Delay N/A BW Delay N/A

PC Delay N/A BW Ovrd N/A

OK Cancel

Next

Next

**Agenda Behavior Transition Detail**

Transition to behavior: Behavior 7

Absolute Time 5:00 PM

Offset N/A N/A N/A

Swt Delay N/A BW Time N/A

Occ Delay N/A BW Delay N/A

PC Delay N/A BW Ovrd N/A

Ignore this area during this process

OK Cancel

Next

**Step 1.7**

Navigate to the Add line of the list, in this case the second line. Click OK to advance to the Behavior Transition Detail screen.

Understanding the Screen

*This Agenda only applies to Monday, as shown here. A transition to Behavior 10 will occur Monday at 8:00 AM.*

**Step 1.8**

The Behavior Transition Detail screen is entered at the Behavior selection box. Use the UP or DOWN arrows to choose the desired Behavior. Consultate the Behavior chart in the Manual for descriptions. For this example change to Behavior 7 (OFF).

**Step 1.9**

Use a combination of the UP and DOWN arrows as well as the NEXT button to change the time to 5:00 PM. When complete, use the NEXT button to navigate to the <OK> on screen button.



- Key
- <Add> On screen button.
- Name- Label of onscreen entry field
- NEXT Button on keypad
- Details Screen Name

**Agenda For Schedule: Office Dimming**

Start Time	Behavior	
8:00 AM	Behavior 10	<input checked="" type="checkbox"/> Mon
5:00 PM	Behavior 7	<input type="checkbox"/> Tue
	Add	<input type="checkbox"/> Wed
		<input type="checkbox"/> Thu
		<input type="checkbox"/> Fri
		<input type="checkbox"/> Sat
		<input type="checkbox"/> Sun

OK Cancel

Next

**Agenda For Schedule: Office Dimming**

Start Time	Behavior	
8:00 AM	Behavior 10	<input checked="" type="checkbox"/> Mon
5:00 PM	Behavior 7	<input type="checkbox"/> Tue
	Add	<input type="checkbox"/> Wed
		<input type="checkbox"/> Thu
		<input type="checkbox"/> Fri
		<input type="checkbox"/> Sat
		<input type="checkbox"/> Sun

OK Cancel

Next  
OK

**Agenda For Schedule: Office Dimming**

Start Time	Behavior	
8:00 AM	Behavior 10	<input checked="" type="checkbox"/> Mon
5:00 PM	Behavior 7	<input checked="" type="checkbox"/> Tue
	Add	<input checked="" type="checkbox"/> Wed
		<input checked="" type="checkbox"/> Thu
		<input checked="" type="checkbox"/> Fri
		<input checked="" type="checkbox"/> Sat
		<input checked="" type="checkbox"/> Sun

OK Cancel

**Step 1.10**

To apply this Agenda or pattern of Behavior to each day of the week press Next to advance to the Day column.

Understanding the Screen

*This Agenda only applies to Monday, as shown here.  
A transition to Behavior 10 will occur Monday at 8:00 AM.  
A transition to Behavior 7 will occur Monday at 5:00 PM.*

**Step 1.11**

Press Next to the -Tuesday- check box. Press -OK- to check the box, this will add Tuesday to the active list.

Repeat this button press combination to fill all check boxes (Mon thru Sun)

**Step 1.12**

Use a combination of the NEXT and OK to fill in the Tuesday through Sunday check boxes.

Understanding the Screen

*This Agenda only applies to Monday through Sunday.  
A transition to Behavior 10 will occur each day at 8:00 AM.  
A transition to Behavior 7 will occur each day at 5:00 PM.*

- Key On screen button.
- <Add> Label of onscreen entry field
- Name- Button on keypad
- NEXT Screen Name
- Details

Home

**Step 1.13**

To save the Schedule, press the NEXT button on the navigation keypad to advance to the <Save> button.

Understanding the Screen

The label value of "MTWTFSS -" on the <Monday> through <Sunday> indicates that the same Agenda applies to each of these days.

There are no Exception Calendars associated with this Schedule.

This Schedule has not been assigned to any Areas.

**Step 1.14**

There is only one Schedule available in the system for the dimming pattern of behavior.

To navigate to the Home screen press the HOME button.

Other Options

To modify an existing Schedule, highlight the appropriate Schedule on the list. Navigate to <Edit> and press OK, to initiate the modification of the selected Schedule.

To delete an existing Schedule, highlight the appropriate Schedule on the list. Navigate to <Delete> and press OK, to erase the selected Schedule.

To adjust the system clock, navigate to <Clock> and press OK.

- Key
- <Add> On screen button.
  - Name- Label of onscreen entry field
  - NEXT Button on keypad
  - Details Screen Name

**Step 2: Configure Devices**

The GreenMAX can be configured to handle a wide variety of input devices. These devices operate at +24vdc and are wired to an input terminal on the Low Voltage (AI) board. Each terminal port must be configured to match the device and its expected functionality.

The following Low Voltage input devices can be connected to the system:

- Occupancy sensors.
- Photocells.
- Switches.
- Contact closures.

**Step 2.1**

The configuration steps of the Low Voltage Input Card is performed in the <Config> section of the HDU software.

Understanding the Screen

There are three sections of the HDU software. The other two sections under the buttons are:

- <Monitor> - Used to check the system time, relay status
- <Control> - Access Scheduling

**Step 2.2**

Use a combination of the UP and DOWN arrows as well as the NEXT button to navigate to the <Inputs> onscreen button. Press OK to select.

**Step 2.3**

The Network Inventory will provide a listing of all system Input devices. This includes both Low Voltage Input Boards (AI) and Digital switches.

Understanding the Screen

There are two Input Devices in this system.

There is a 16 input AI board at address ID 16.

There is a 4 button Digital Switch at address ID 4.

Description of the onscreen buttons:

- <Edit> selecting this onscreen button will allow editing of the highlighted device in the list.
- <Tools> use to navigate to the **System Tools** screen.
- <Panels> use to navigate to the **Relay Panel Detail Screen**
- <Groups> use to navigate to the **Group** building screen
- <Areas> use to navigate to the **Areas** configuration screen

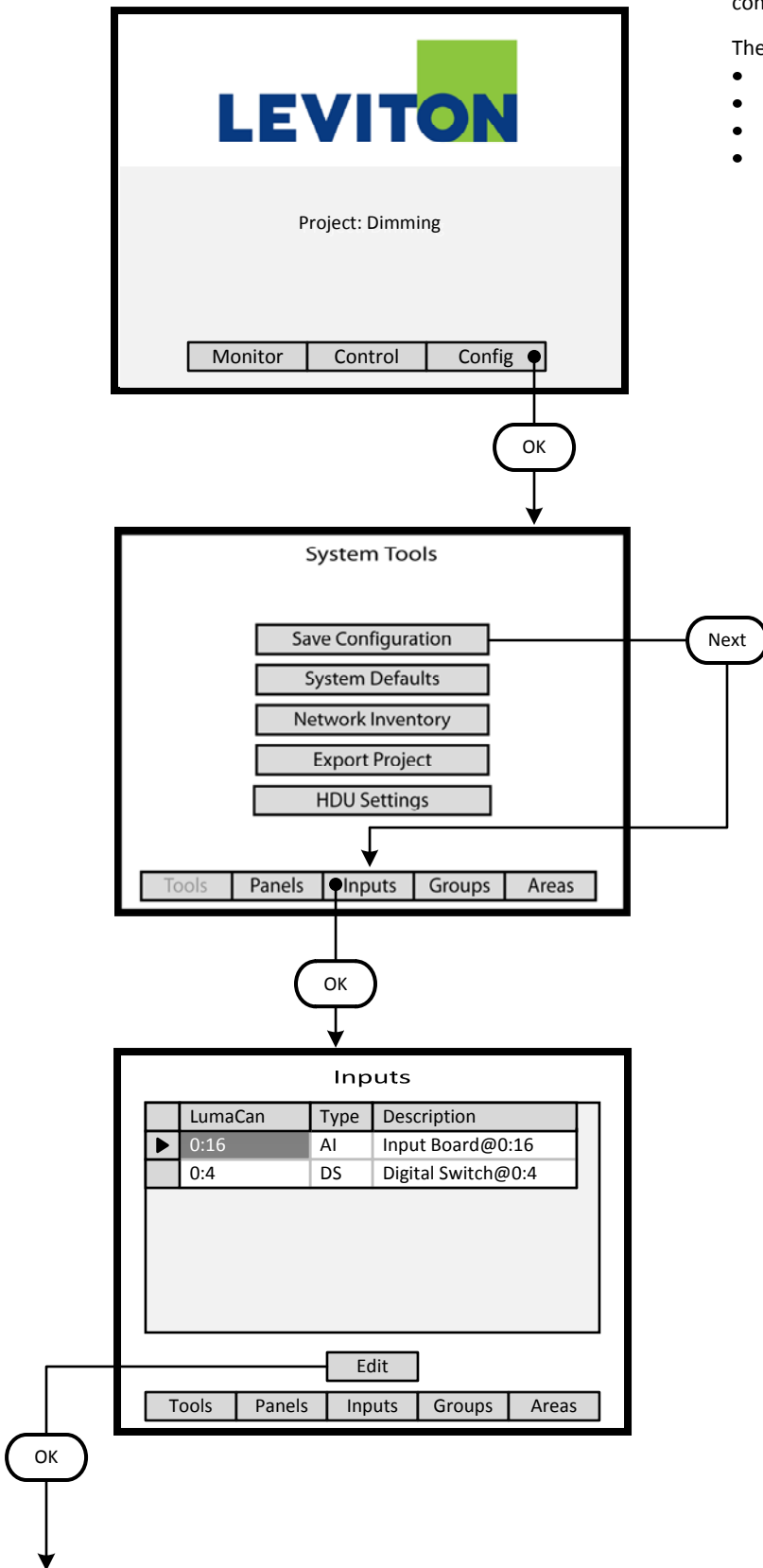

- Key
- <Add> On screen button.
- Name- Label of onscreen entry field
- NEXT Button on keypad
- Details Screen Name

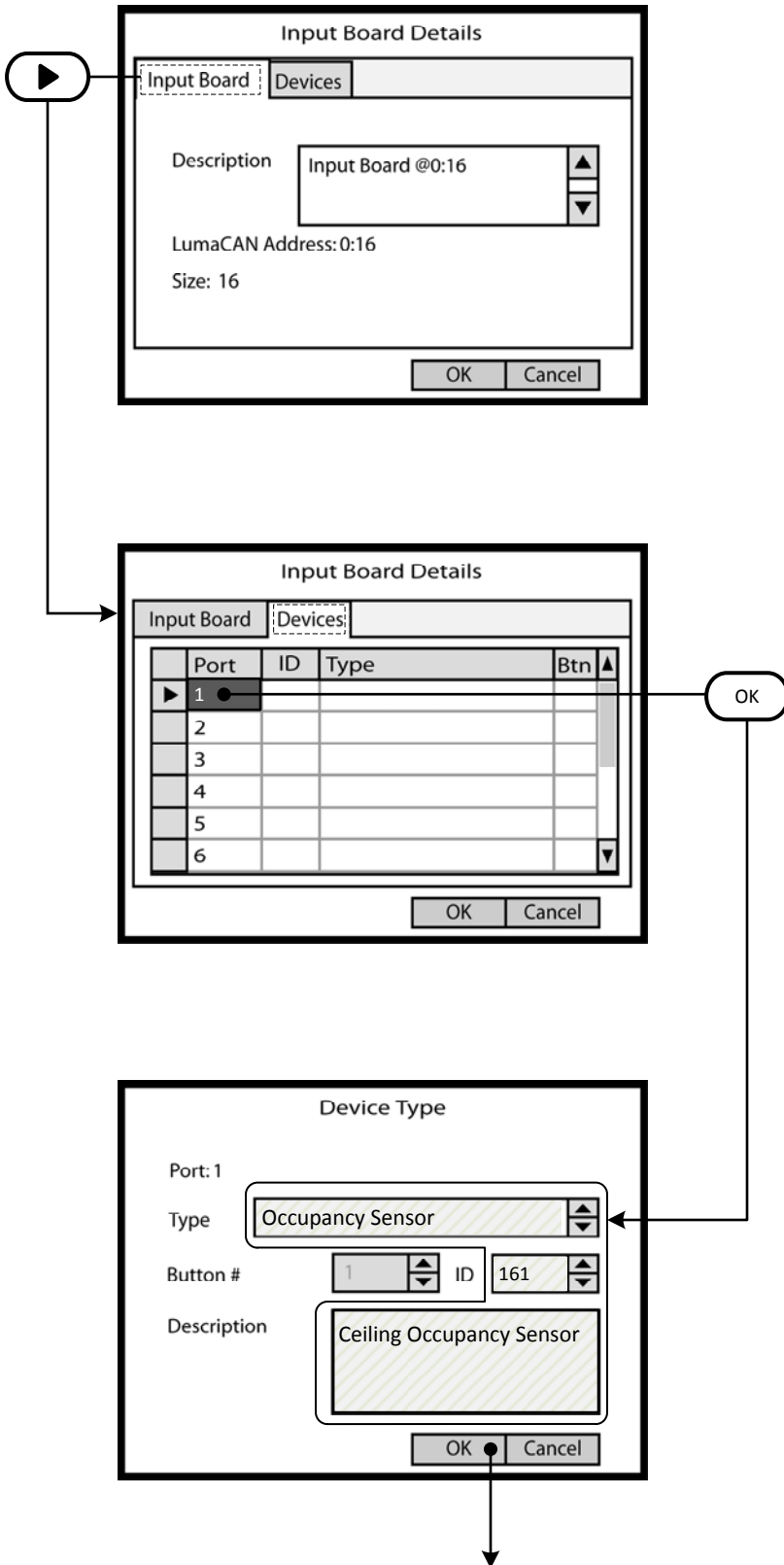

**Step 2.4**

The **Input Board Details** screen displays the number of inputs, the LumaCan address ID and the **-Description-** field. Enter job specific description in this field. Once the correct information is entered, use the RIGHT arrow to move to the **-Devices-** tab at the top of the screen.

Understanding the Screen

The other onscreen buttons are:  
 <OK> - Used to accept the entries  
 <Cancel> - Used to discard entries

**Step 2.5**

The **-Devices-** tab reveals a list of the Input Ports on the AI Board being configured. Ports are numbered sequentially in quantities of 8 or 16. No data entry can be made on this screen. Highlight the Input Port number and press OK to enter the editing screen.

Use the UP or DOWN arrows on the keypad to navigate up or down the list. The scroll bar to the right indicates position on the list.

If the wrong device type appears on the list, highlight the Input Port number and press CLEAR on the keypad.

Understanding the Screen

No devices have been configured for this AI board.  
 The onscreen buttons are:  
 <OK> - Used to accept the entries  
 <Cancel> - Used to discard entries

**Step 2.6**

The Device Type screen is used to select the type of device that is wired to the input port. Use the UP and DOWN arrows on the keypad to display the desired device. The Description field should be used to document the location of the device.

Understanding the Screen

The **-Button #-** is available for display purposes only and does not have any configuration value.  
 The description is limited to 25 characters.

The **-ID-** is available for display purposes only and does not have any configuration value. It can be used to match the numbering on project drawings. Maximum value is 1000.

- Key
- <Add> On screen button.
- Name- Label of onscreen entry field
- NEXT Button on keypad
- Details Screen Name

**Input Board Details**

Input Board	Devices			
Port	ID	Type	Btn	
1	161	Occupancy Sensor		
2	162	Closed Loop Photocell		
3				
4				
5				
6				

OK Cancel

OK

**Inputs**

LumaCan	Type	Description
0:16	AI	Input Board@0:16
0:4	DS	Digital Switch@0:4

Edit

Tools Panels Inputs Groups Areas

Next

**Inputs**

LumaCan	Type	Description
0:16	AI	Input Board@0:16
0:4	DS	Digital Switch@0:4

Edit

Tools Panels Inputs Groups Areas

OK

**Step 2.8**

A populated **Input Board Details** screen will look as shown here. The Input Ports can be configured in any order as necessary.

Understanding the Screen

Only Ports 1 & 2 are populated. The ID numbers are for information purposes. They can be any number that makes sense to the user. The system only stores these numbers and does not use them for any function other than identification. The 'Btn' column will be populated with switch button numbers if Low Voltage Switches are configured at the Port location.

- The other onscreen buttons are:
- <OK> - Used to accept the entries
- <Cancel> - Used to discard entries

**Step 2.9**

The **Inputs** listing shows a Digital Switch at LumaCan ID 4. This is a 4 button Digital Switch to be used for Dimming control. Highlight the device and move the indicator to the appropriate device line. Use the UP and DOWN arrows to move about the list. Use NEXT to navigate to the <Edit> button.

- Key On screen button.
- <Add> Label of onscreen entry field
- Name- Button on keypad
- NEXT Screen Name

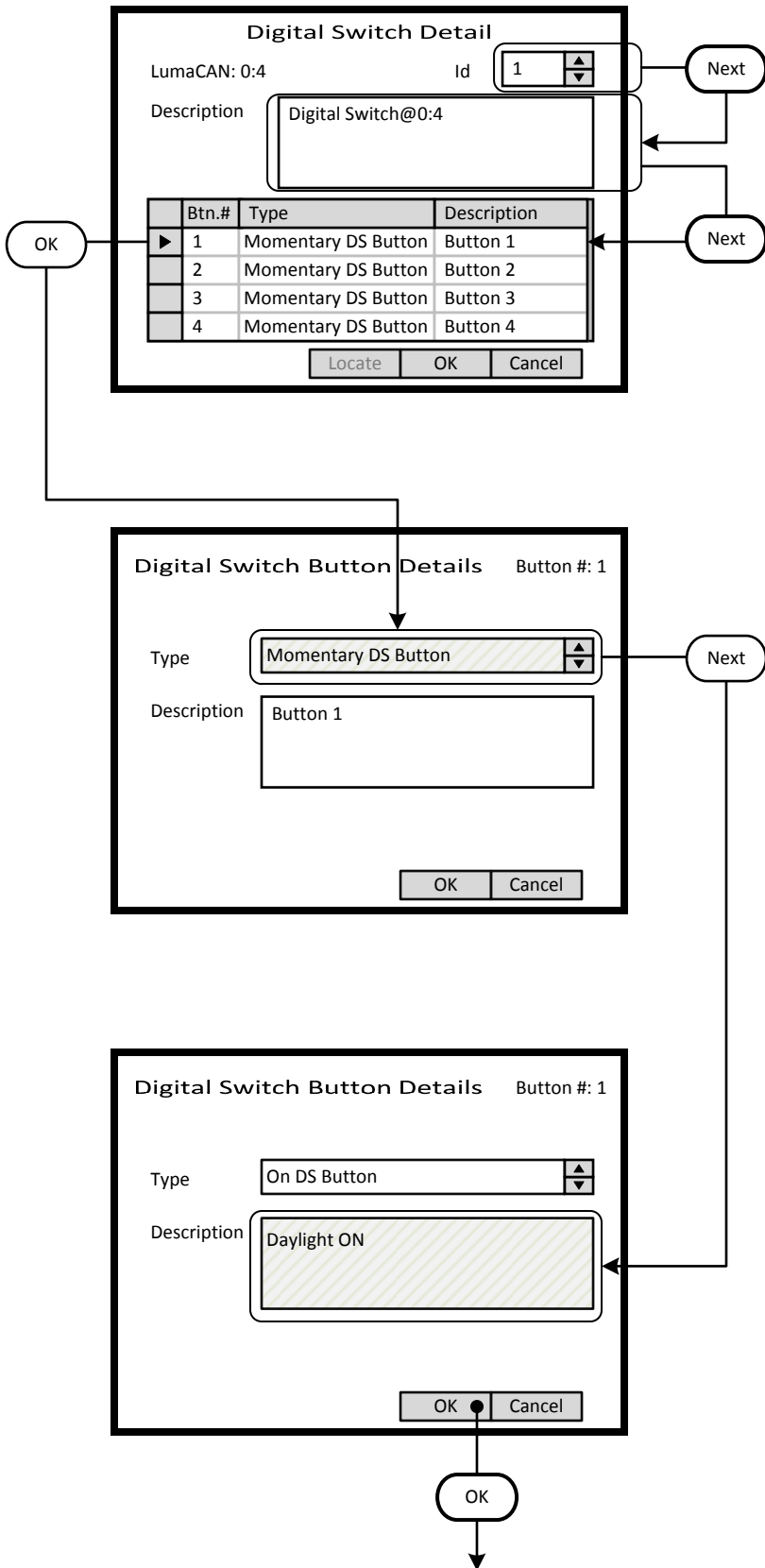

**Step 2.10**

The **Digital Switch Detail** screen provides an ID setting for informational purposes. This can match the switch number on the building floor plan. For this exercise this will be set to 12.

A switch **-Description-** field is provided that can be filled with a maximum of 25 characters of information.

Button function must be configured. Highlight the Button number and press OK to enter the editing screen. These fields fill the list on the previous screen.

Use the UP or DOWN arrows on the keypad to navigate up or down the list.

**Step 2.11**

The Digital Switch Button Details screen is used to configure the individual button function and to name the button. Use the UP and DOWN arrows on the keypad to display the desired button function.

The Description field should be used to document the function of the individual buttons. This field is for user reference only.

Understanding the Screen

- The type options are:
- Momentary DS Button
  - On DS Button
  - Bright DS Button
  - Dim DS Button
  - Off DS Button

- Key
- <Add> On screen button.
- Name- Label of onscreen entry field
- NEXT Button on keypad
- Details Screen Name

**Digital Switch Detail**

LumaCAN: 0:4                      Id

Description

Btn.#	Type	Description
▶ 1	On DS Button	Daylight On
2	Bright DS Button	Bright Btn
3	Dim DS Button	Dim Btn
4	Off DS Button	Daylight Off

OK

**Inputs**

	LumaCan	Type	Description
	0:16	AI	Input Board@0:16
▶	0:4	DS	Dimming Zone 1

Next

**Inputs**

	LumaCan	Type	Description
	0:16	AI	Input Board@0:16
▶	0:4	DS	Dimming Zone 1

OK

**Step 2.12**

This illustration shows the recommended configuration for a Digital Switch used for dimming control application. The button Type fields should match those shown. Each field should be adjusted individually. Button descriptions are entered on the Button Detail Screen shown previous.

Use the UP or DOWN arrows on the keypad to navigate up or down the list.

Use NEXT and BACK to navigate between sections on the screen.

Understanding the Screen

The ID number are for information purposes and can be used to match assigned project switch numbers.

**Step 2.13**

The Inputs list has a Digital Switch at ID 4 and is described as Dimming Zone 1.

Use the UP and DOWN arrows to move about the list. Use NEXT to navigate to the <Areas> button.

**Step 2.14**

The Inputs list has an Low Voltage Input Board (AI) at LumaCan ID 16 and a Digital Switch (DS) at LumaCan ID 4 that is described as Dimming Zone 1.

Use NEXT to navigate to the <Areas> button. Press OK to advance to the Areas maintenance screen.

- Key
- <Add> On screen button.
- Name- Label of onscreen entry field
- NEXT Button on keypad
- Details Screen Name

**Step 3: Create an Area**

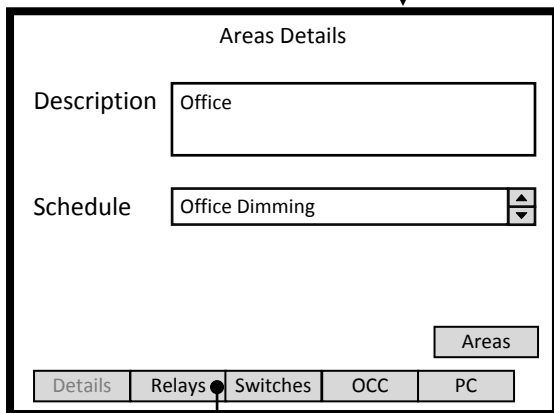
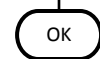
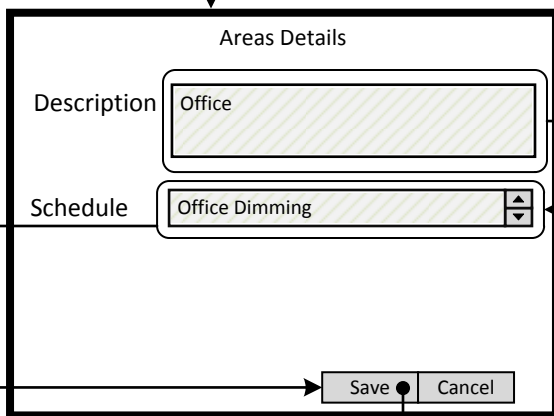
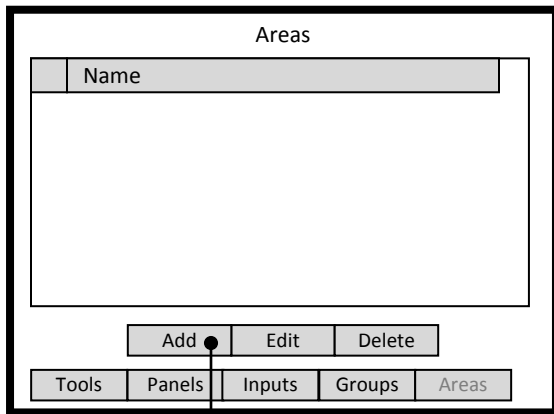

**Step 3.1**

The **Areas** screen lists all the current Areas available in the system. At this step there are no existing Areas. To create a new Area navigate to the <Add> onscreen button and press OK.

Understanding the Screen

There are no Areas in this system.

Description of the onscreen buttons:

- <Edit> selecting this onscreen button will allow editing of the highlighted Area in the list.
- <Delete> selecting this onscreen button will permanently remove the highlighted Area from the list.
- <Tools> use to navigate to the System Tools screen.
- <Panels> use to navigate to the Relay Panel Detail Screen
- <Groups> use to navigate to the Group building screen
- <Areas> use to navigate to the Areas configuration screen

**Step 3.2**

Enter the desired Area name and detail in the -Description- field. Enter as much information as practical. The Area must be assigned to a Schedule. An area can only be assigned to one schedule at a time. All of the available system Schedules will appear in the -Schedule- list box.

Understanding the Screen

To appear in the -Schedule- list box, Schedules must be created prior to entering this screen. See the "Create a Schedule" section.

Description of the onscreen buttons:

- <Save> selecting this onscreen button will create the Area, save it, and add advance to the next screen
- <Cancel> used to discard entries

**Step 3.3**

The newly created Area will contain relays and associated control devices. Additional navigation buttons are available to navigate to screens that populate or edit the contents of the Area. To add relays to the Area, navigate to the <Relay> onscreen button and press OK.

Understanding the Screen

Description of the onscreen buttons:

- <Areas> use to navigate to the Areas list screen
- <Relays> selecting this onscreen button will allow the addition/editing of assigned relays
- <Switches> selecting this onscreen button to add/edit assigned switches
- <OCC> selecting this onscreen button to add/edit assigned Occupancy Sensors
- <PC> selecting this onscreen button to add/edit assigned Photocells



- Key
- <Add> On screen button.
- Name- Label of onscreen entry field
- NEXT Button on keypad
- Details Screen Name

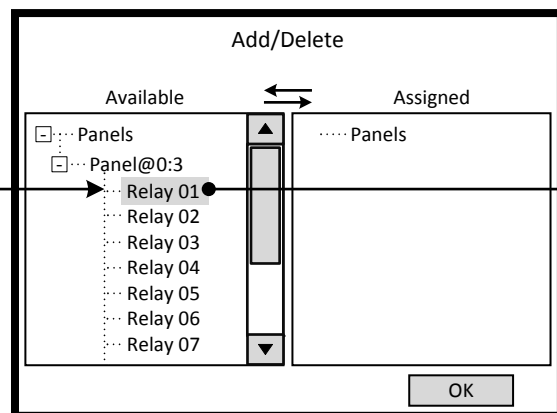
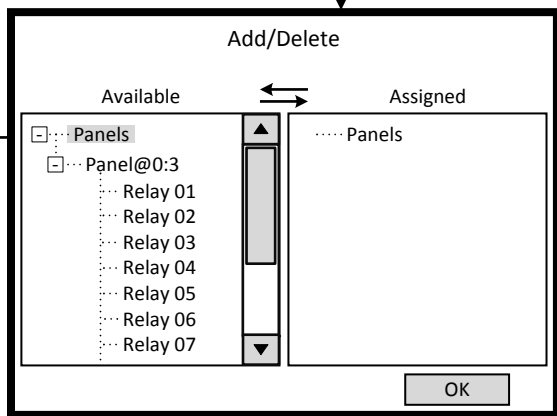
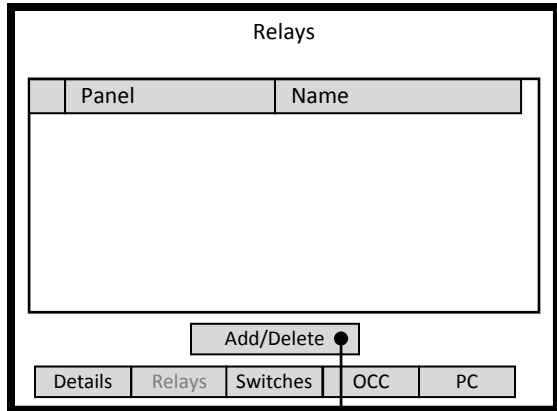

**Step 3.4**

The **Relays** screen lists all the current relays assigned to the Area. To add a new relay to the Area navigate to the <Add/Delete> onscreen button and press OK.

Understanding the Screen

There are currently no relays assigned to the Area.

Description of the onscreen buttons:

- <Details> use to navigate to the **Area Details** screen
- <Switches> selecting this onscreen button to add/edit assigned switches
- <OCC> selecting this onscreen button to add/edit assigned Occupancy Sensors
- <PC> selecting this onscreen button to add/edit assigned Photocells

**Step 3.5**

The left side of the screen under the heading **-Available-** lists all of the relays that have not been assigned to an Area. If the desired relay is not on this list it has been assigned to another Area. Relays are displayed according to the panel they are installed in. All unassigned relays in the system can be seen on this list.

Understanding the Screen

Complete panels may be collapsed by highlighting name on the list pressing OK.

Description of the onscreen button:

- <OK> selecting this onscreen button will save the selections made and return to the **Relays** list screen.

**Step 3.6**

Relays are added to the Area by moving them from the **-Available-** list to the **-Assigned-** list. This is accomplished by highlighting the desired relay on the left side of the screen and using the right arrow to move it to the right side of the screen.

Understanding the Screen

Currently there are no relays assigned to this Area. Relays 01 through 07 are available for assignment. Relay 01 of Panel 3 has been selected as a candidate for assignment to the Area.

- Key
- <Add> On screen button.
- Name- Label of onscreen entry field
- NEXT Button on keypad
- Details Screen Name

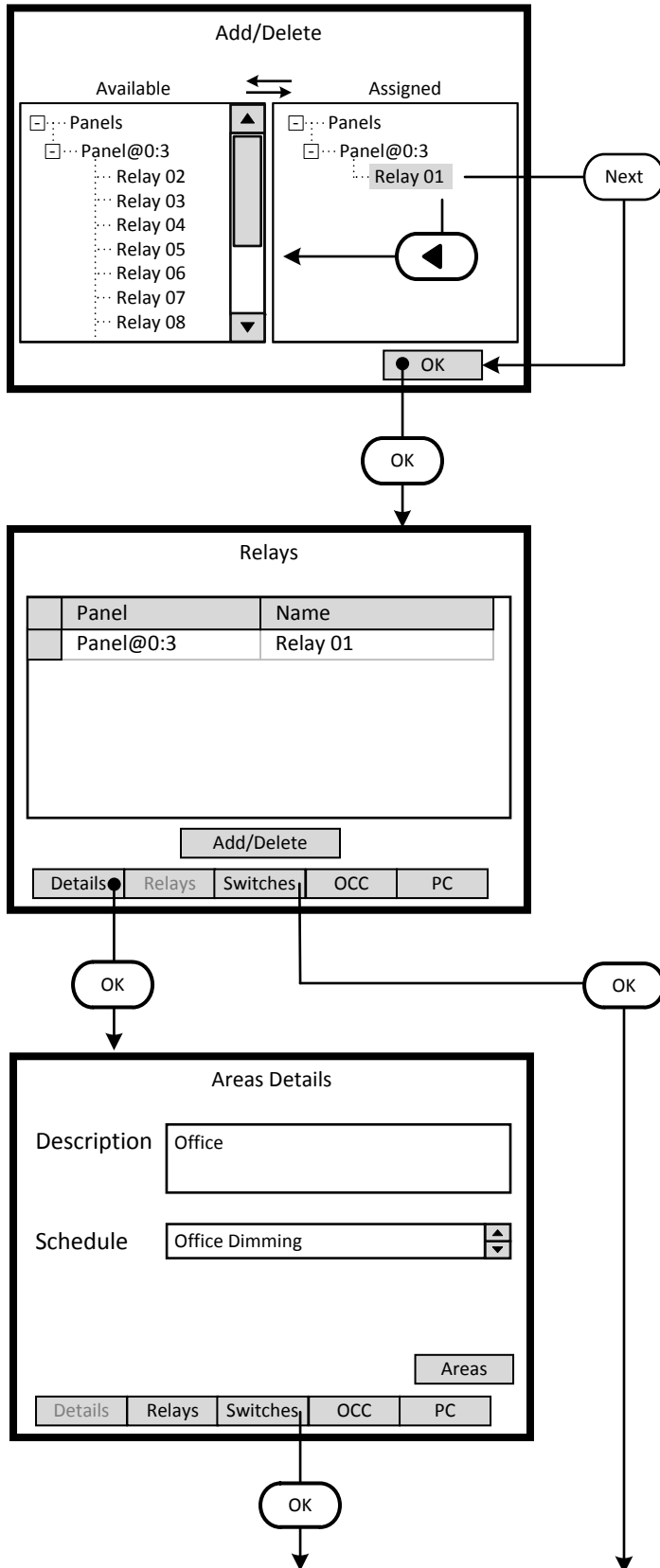

**Step 3.7**

Relays are deleted from the Area by moving them from the **-Assigned-** list to the **-Available-** list. This is accomplished by highlighting the desired relay on the right side of the screen and using the left arrow to move it to the right side of the screen. To accept the assignment, navigate to the **-OK-** onscreen button and press OK or Enter.

Understanding the Screen

Currently Relay 01 of Panel 3 has been assignment to the Area.  
Relays 02 through 07 are available for assignment.

**Step 3.8**

The **-Relays-** screen lists the relays assigned to the Area. This list will be displayed each time this section of the Area information is entered. The next common step is to add switch buttons to the Area.

Understanding the Screen

Currently only Relay 01 of Panel 3 has been assignment to the Area.  
There are two navigating paths to the next screen. Using the **<Switches>** onscreen button skips a screen and goes directly to the **-Switches-** screen.

Description of the onscreen buttons:

- <Details> use to navigate to the **-Area Details-** screen
- <Switches> use to navigate to the **-Switches-** screen
- <OCC> use to navigate to the **-Occupancy Sensors-** screen
- <PC> use to navigate to the **-Photocells-** screen

- Key On screen button.
- <Add> Label of onscreen entry field
- Name- Button on keypad
- NEXT Screen Name
- Details Screen Name

**Step 4: Switch Buttons**

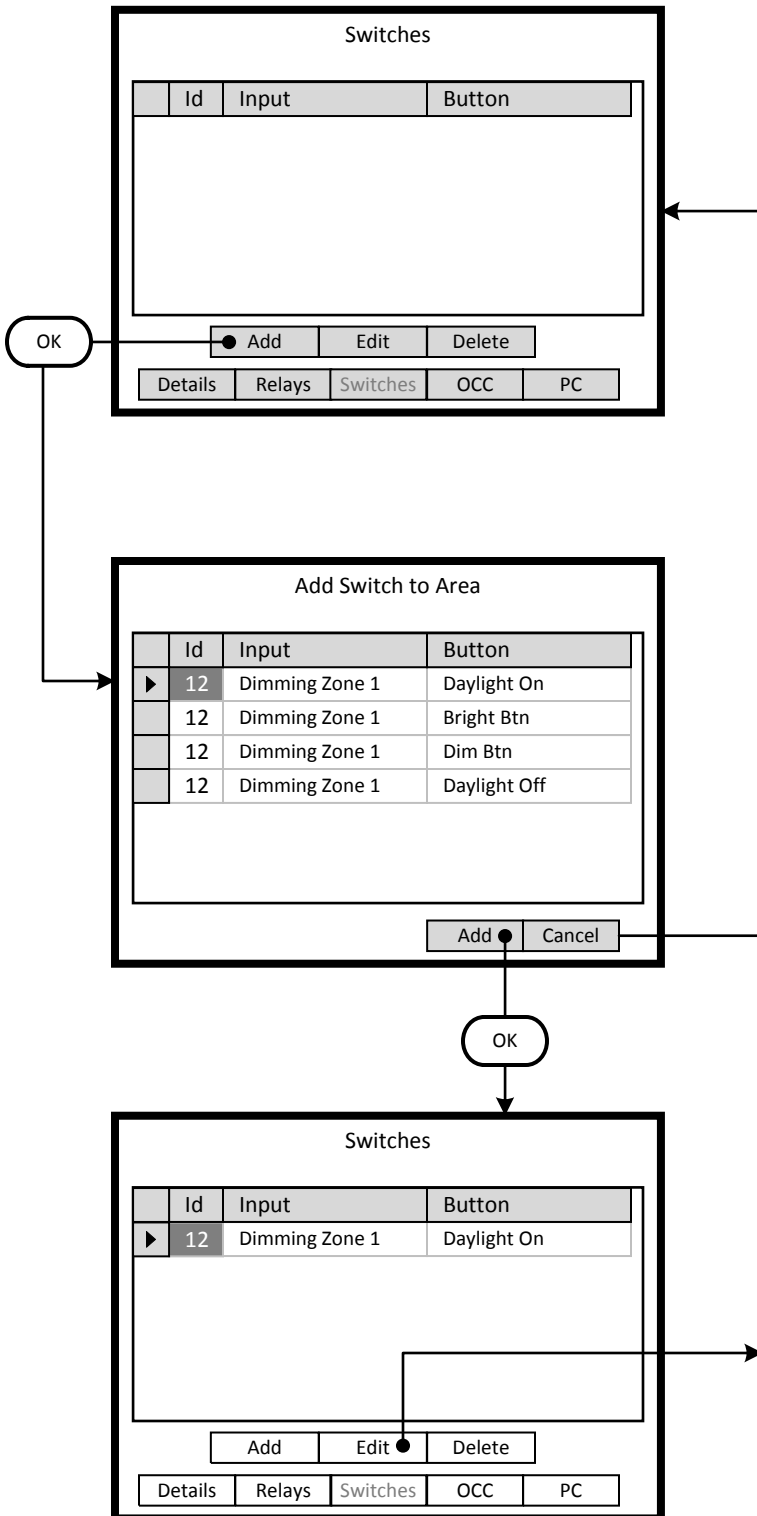

**Step 4.1**

The **-Switches-** screen lists the switch buttons assigned to the Area. This list will be displayed each time this section of the Area information is entered. The next common step is to add switch buttons to the Area.

Understanding the Screen

Currently there are no switch buttons assigned to the Area.

Description of the onscreen buttons:

- <Details> use to navigate to the **-Area Details-** screen
- <Relays> use to navigate to the **-Relays-** screen
- <OCC> use to navigate to the **-Occupancy Sensors-** screen
- <PC> use to navigate to the **-Photocells-** screen

**Step 4.2**

The **-Add Switch to Area-** screen lists the available and unassigned switch buttons for the system. As a switch button is assigned to an Area, it is removed from this list.

Understanding the Screen

The highlighted button, button 1 of the switch at LumaCan address 4 can be added to the Area by selecting the **<Add>** onscreen button.

Description of the onscreen buttons:

- <Cancel> use to navigate to the **-Area Details-** screen

**Step 4.3**

The **-Switches-** screen lists the switch buttons assigned to the Area. This list will be displayed each time this section of the Area information is entered.

Understanding the Screen

Currently button 1 of the switch at LumaCan address 4 is assigned to the Area.

Description of the onscreen buttons:

- <Add> use to navigate to the **-Add Switch to Area-** screen
- <Delete> use to delete the highlighted button
- <Details> use to navigate to the **-Area Details-** screen
- <Relays> use to navigate to the **-Relays-** screen
- <OCC> use to navigate to the **-Occupancy Sensors-** screen
- <PC> use to navigate to the **-Photocells-** screen

- Key
- <Add> On screen button.
- Name- Label of onscreen entry field
- NEXT Button on keypad
- Details Screen Name

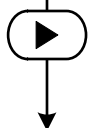
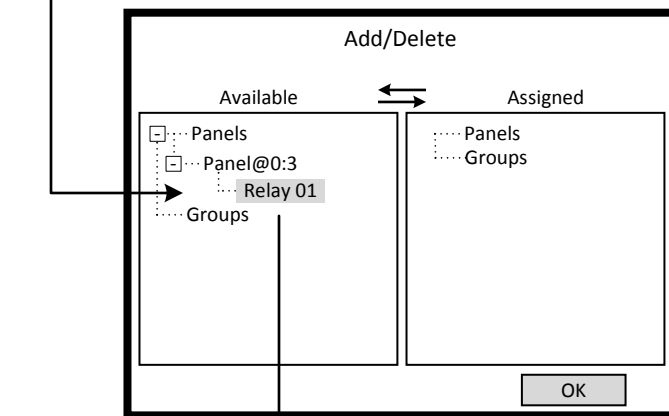
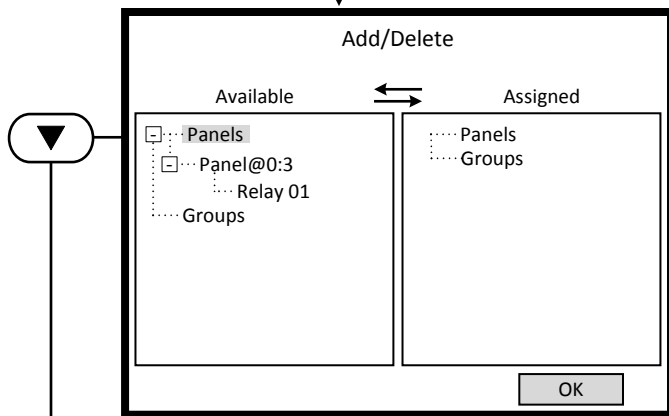
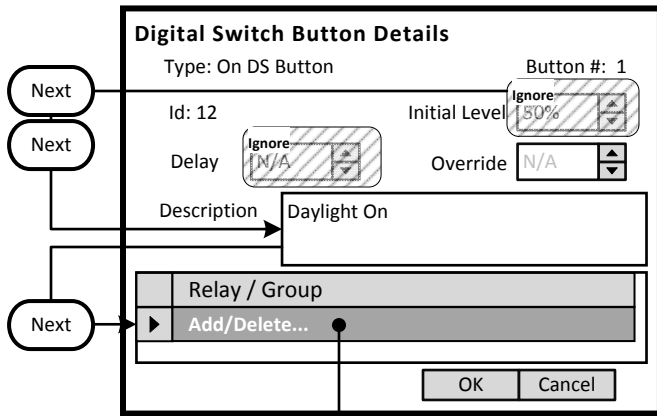

**Step 4.4**

This screen configures the characteristics of the switch button. The **-Relay / Group-** list will be populated with the corresponding controlled relays or groups.

Understanding the Screen

The **-Description-** field can be edited on this screen. Information from the **Digital Switch Detail** screen will be displayed here. Ignore the settings of **-Initial Level-**, **-Delay-** and **-Override-**.

Description of the onscreen buttons:

- <OK> save the selections made and return to the **Switches** list screen.
- <Cancel> use to discard entries and return to previous screen

**Step 4.5**

The left side of the screen under the heading **-Available-** lists all of the relays that have been assigned to an Area. If the desired relay is not on this list it has not been assigned to this Area. Relays are displayed according to the panel they are installed in. Use the navigation keypad to highlight the desired relay.

Understanding the Screen

Complete panels may be collapsed by highlighting name on the list pressing OK.

Description of the onscreen button:

- <OK> selecting this onscreen button will save the selections made and return to the **Relays** list screen.

**Step 4.6**

Relays are assigned to the Switch button by moving them from the **-Available-** list to the **-Assigned-** list. This is accomplished by highlighting the desired relay on the left side of the screen and using the right arrow to move it to the right side of the screen.

Understanding the Screen

Currently there are no relays assigned to this Switch Button. Relay 01 of Panel 3 has been selected as a candidate for assignment to the Switch Button.

- Key On screen button.
- <Add> Label of onscreen entry field
- Name- Button on keypad
- NEXT Button on keypad
- Details Screen Name

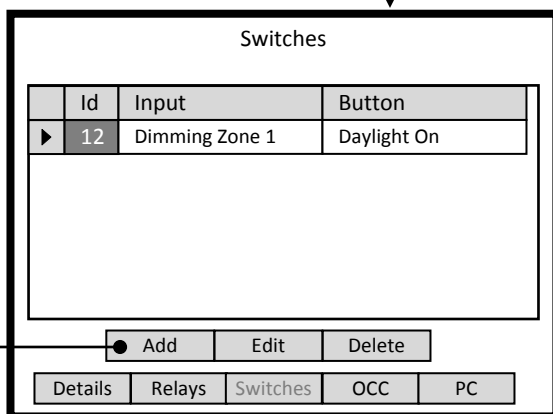
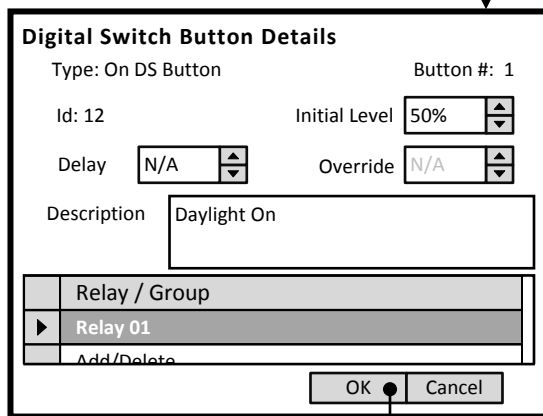
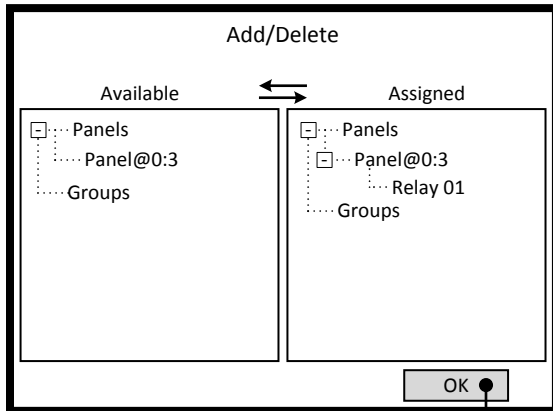

**Step 4.7**

Relay 01 is assigned to the control of the Switch Button. To remove it, highlight the relay in the **-Assigned-** list and press the Left arrow button of the navigation keypad. The relay will move back to the **-Available-** list on the left side of the screen.

Understanding the Screen

Relay 01 of Panel 3 has is assigned to the Switch Button. No other relays are currently available in the Area.

Description of the onscreen buttons:

<OK> use to accept entries and navigate to the **-Digital Switch Button Details-** screen

**Step 4.8**

Relay 01 is assigned to the control of the Switch Button 1. To remove it, highlight the relay in the **-Assigned-** list and press the Left arrow button of the navigation keypad. The relay will move back to the **-Available-** list on the left side of the screen.

Understanding the Screen

Relay 01 of Panel 3 has is assigned to the Switch Button. Relay 01 of Panel 3 will start daylight harvesting when button 1 of switch ID: 12 is pressed. The settings of **-Initial Level-**, **-Delay-** and **-Override-** do not apply.

Description of the onscreen buttons:

- <OK> use to accept entries and navigate to the **-Switches-** screen
- <Cancel> use to abandon entries and navigate to the **-Switches-** screen

**Step 4.9**

All four of the Buttons for the Switch must be assigned to the Area. This summary list will be displayed each time this section of the Area information is entered. Navigate to the <Add> button and press OK button on the keypad.

Understanding the Screen

Currently there is one switch button assigned to the Area. Description of the onscreen buttons:

- <Edit> use to navigate to the **-Digital Switch Button Details-** screen to make modifications to settings of the highlighted button
- <Delete> use to delete the highlighted button from the Area
- <Details> use to navigate to the **-Area Details-** screen
- <Relays> use to navigate to the **-Relays-** screen
- <OCC> use to navigate to the **-Occupancy Sensors-** screen
- <PC> use to navigate to the **-Photocells-** screen

- Key
- <Add> On screen button.
- Name- Label of onscreen entry field
- NEXT Button on keypad
- Details Screen Name

**Add Switch to Area**

	Id	Input	Button
▶	12	Dimming Zone 1	Bright Btn
	12	Dimming Zone 1	Dim Btn
	12	Dimming Zone 1	Daylight Off

OK

**Switches**

	Id	Input	Button
	12	Dimming Zone 1	Daylight On
▶	12	Dimming Zone 1	Bright Btn

Details
Relays
Switches
OCC
PC

OK

**Add Switch to Area**

	Id	Input	Button
▶	12	Dimming Zone 1	Dim Btn
	12	Dimming Zone 1	Daylight Off

OK

**Step 4.10**

The **-Add Switch to Area-** screen lists the available and unassigned switch buttons for the system. As a switch button is assigned to an Area, it is removed from this list.

Understanding the Screen

The highlighted button, *Bright Btn* button of the switch ID 12 at LumaCan address 4 can be added to the Area by selecting the **<Add>** onscreen button.

Description of the onscreen buttons:

**<Cancel>** use to navigate to the **-Area Details-** screen

**Step 4.11**

The **-Switches-** screen lists the switch buttons assigned to the Area. This summary list will be increase as each button is added.

Understanding the Screen

Currently 2 buttons are assigned; *Daylight On, Bright Btn* of switch ID 12 at LumaCan address 4.

Description of the onscreen buttons:

**<Add>** use to navigate to the **-Add Switch to Area-** screen

**<Delete>** use to delete the highlighted button

**<Details>** use to navigate to the **-Area Details-** screen

**<Relays>** use to navigate to the **-Relays-** screen

**<OCC>** use to navigate to the **-Occupancy Sensors-** screen

**<PC>** use to navigate to the **-Photocells-** screen

**Step 4.12**

Continue to add all of the relevant buttons to the Area.

Understanding the Screen

The highlighted button, *Dim Btn* button of the switch ID 12 at LumaCan address 4 can be added to the Area by selecting the **<Add>** onscreen button.

Description of the onscreen buttons:

**<Cancel>** use to navigate to the **-Area Details-** screen

- Key On screen button.
- <Add> Label of onscreen entry field
- NEXT Button on keypad
- Details Screen Name

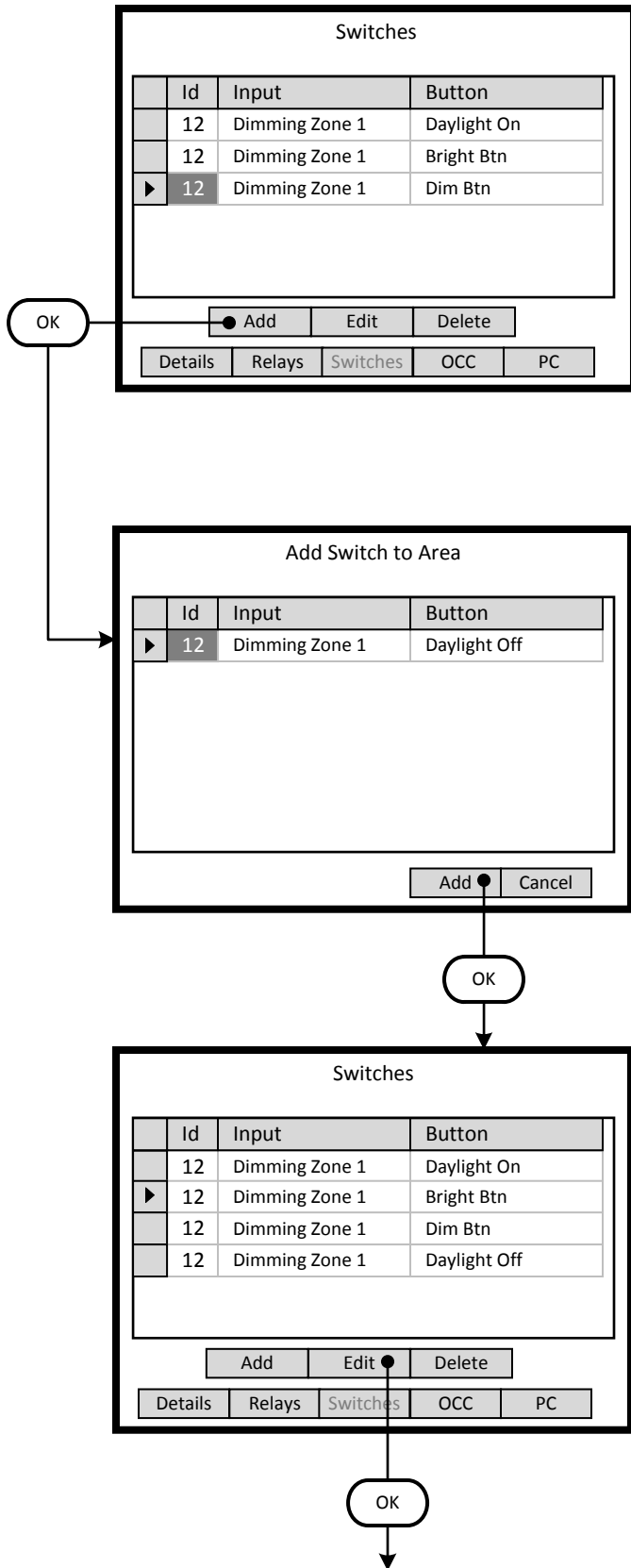

**Step 4.13**

The **-Switches-** screen lists the switch buttons assigned to the Area. This summary list will be increase as each button is added.

Understanding the Screen

Currently 3 buttons are assigned; Daylight On, Bright Btn, Dim Btn of switch ID 12 at LumaCan address 4.

*Description of the onscreen buttons:*

- <Add> use to navigate to the **-Add Switch to Area-** screen
- <Delete> use to delete the highlighted button
- <Details> use to navigate to the **-Area Details-** screen
- <Relays> use to navigate to the **-Relays-** screen
- <OCC> use to navigate to the **-Occupancy Sensors-** screen
- <PC> use to navigate to the **-Photocells-** screen

**Step 4.14**

Continue to add all of the relevant buttons to the Area.

Understanding the Screen

The highlighted button, Daylight Off button of the switch ID 12 at LumaCan address 4 can be added to the Area by selecting the <Add> onscreen button.

*Description of the onscreen buttons:*

- <Cancel> use to navigate to the **-Area Details-** screen

**Step 4.15**

All four of the buttons for the switch have been added to the Area. Each of the buttons must be assigned to the relay to be controlled. The Daylight On button was previously configured in Step 4.4. Navigate to the <Edit> button and press OK button on the keypad to configure each button of the remaining three buttons.

Understanding the Screen

Currently there is one switch button assigned to the Area.

*Description of the onscreen buttons:*

- <Delete> use to delete the highlighted button from the Area
- <Details> use to navigate to the **-Area Details-** screen
- <Relays> use to navigate to the **-Relays-** screen
- <OCC> use to navigate to the **-Occupancy Sensors-** screen
- <PC> use to navigate to the **-Photocells-** screen

- Key On screen button.
- <Add> Label of onscreen entry field
- Name- Button on keypad
- NEXT Screen Name

Switches			
	Id	Input	Button
	12	Dimming Zone 1	Daylight On
	12	Dimming Zone 1	Bright Btn
	12	Dimming Zone 1	Dim Btn
	12	Dimming Zone 1	Daylight Off

Add Edit Delete

Details Relays Switches OCC PC

OK

**Digital Switch Button Details**

Type: Bright DS Button

Id: 12

Delay: Ignore / N/A

Description: Bright Btn

Button #: 2

Initial Level: Ignore / 150%

Override: 20 min

Relay / Group
Add/Delete...

OK Cancel

Next

Next

Next

Next

OK

**Add/Delete**

Available

- Panel@0:3
- Relay 01

↔

Assigned

- Panel@0:3
- Relay 01

OK

OK

**Step 4.16**

The three new buttons listed on the **-Switches-** screen require configuration. Highlight the desired button and navigate to the **<Edit>** onscreen button.

Understanding the Screen

Currently all buttons of the switch at LumaCan address 4 are assigned to the Area.

Description of the onscreen buttons:

- <Add> use to navigate to the **-Add Switch to Area-** screen
- <Delete> use to delete the highlighted button
- <Details> use to navigate to the **-Area Details-** screen
- <Relays> use to navigate to the **-Relays-** screen
- <OCC> use to navigate to the **-Occupancy Sensors-** screen
- <PC> use to navigate to the **-Photocells-** screen

**Step 4.17**

The Bright DS button will temporarily increase the light level from the Target Level of the photocell. The **-Override-** field is set for the duration that the Bright manual override is active. At the conclusion of this interval, the zone will return to the photocell Target Level. The **-Relay / Group-** list will be populated with the corresponding controlled relays or groups.

Understanding the Screen

Ignore the settings of **-Initial Level-** and **-Delay-**.

Description of the onscreen buttons:

- <OK> save the selections made and return to the **Switches** list screen.
- <Cancel> use to discard entries and return to previous screen

**Step 4.18**

Use the instructions outlined in Steps 4.5 through 4.7 to assign Relay 01 to the control of the Switch Button.

To remove it, highlight the relay in the **-Assigned-** list and press the Left arrow button of the navigation keypad. The relay will move back to the **-Available-** list on the left side of the screen.

Understanding the Screen

Relay 01 of Panel 3 has is assigned to the Switch Button. No other relays are currently available in the Area.

Description of the onscreen buttons:

- <OK> use to accept entries and navigate to the **-Digital Switch Button Details-** screen



- Key On screen button.
- <Add> Label of onscreen entry field
- Name- Button on keypad
- NEXT Screen Name

Switches			
	Id	Input	Button
	12	Dimming Zone 1	Daylight On
	12	Dimming Zone 1	Bright Btn
	12	Dimming Zone 1	Dim Btn
	12	Dimming Zone 1	Daylight Off

Add Edit Delete

Details Relays Switches OCC PC

OK

**Digital Switch Button Details**

Type: Dim DS Button

Id: 12

Delay: Ignore

Description: Dim Btn

Button #: 3

Initial Level: Ignore 50%

Override: 20 min

Relay / Group
▶ Add/Delete...

OK Cancel

Next

Next

Next

Next

OK

**Add/Delete**

Available

- Panel@0:3
- Relay 01

Assigned

- Panel@0:3
- Relay 01

OK

OK

**Step 4.19**

Configure the next button listed on the **-Switches-** screen. Highlight the desired button and navigate to the **<Edit>** onscreen button.

Understanding the Screen

Currently all buttons of the switch at LumaCan address 4 are assigned to the Area.

Description of the onscreen buttons:

- <Add> use to navigate to the **-Add Switch to Area-** screen
- <Delete> use to delete the highlighted button
- <Details> use to navigate to the **-Area Details-** screen
- <Relays> use to navigate to the **-Relays-** screen
- <OCC> use to navigate to the **-Occupancy Sensors-** screen
- <PC> use to navigate to the **-Photocells-** screen

**Step 4.20**

The Bright DS button will temporarily decrease the light level from the Target Level of the photocell. The **-Override-** field is set for the duration that the Dim manual override is active. At the conclusion of this interval, the zone will return to the photocell Target Level. The **-Relay / Group-** list will be populated with the corresponding controlled relays or groups.

Understanding the Screen

Ignore the settings of **-Initial Level-** and **-Delay-**.

Description of the onscreen buttons:

- <OK> save the selections made and return to the **Switches** list screen.
- <Cancel> use to discard entries and return to previous screen

**Step 4.21**

Use the instructions outlined in Steps 4.5 through 4.7 to assign Relay 01 to the control of the Switch Button. To remove it, highlight the relay in the **-Assigned-** list and press the Left arrow button of the navigation keypad. The relay will move back to the **-Available-** list on the left side of the screen.

Understanding the Screen

Relay 01 of Panel 3 has is assigned to the Switch Button. No other relays are currently available in the Area.

Description of the onscreen buttons:

- <OK> use to accept entries and navigate to the **-Digital Switch Button Details-** screen

- Key On screen button.
- <Add> Label of onscreen entry field
- Name- Button on keypad
- NEXT Screen Name

Switches			
	Id	Input	Button
	12	Dimming Zone 1	Daylight On
▶	12	Dimming Zone 1	Bright Btn
	12	Dimming Zone 1	Dim Btn
	12	Dimming Zone 1	Daylight Off

Add Edit Delete

Details Relays Switches OCC PC

OK

**Digital Switch Button Details**

Type: Off DS Button

Id: 12

Delay: Ignore / N/A

Description: Daylight Off

Button #: 4

Initial Level: Ignore / 10%

Ignore Override: Ignore / 20 min

	Relay / Group
▶	Add/Delete...

OK Cancel

- Next
- Next
- Next
- Next

OK

**Add/Delete**

Available

- ▶ Panels
- Panel@0:3
- Groups

↔

Assigned

- ▶ Panels
- Panel@0:3
- Relay 01
- Groups

OK

OK

**Step 4.22**

The three new buttons listed on the **-Switches-** screen require configuration. Highlight the desired button and navigate to the **<Edit>** onscreen button.

Understanding the Screen

Currently all buttons of the switch at LumaCan address 4 are assigned to the Area.

Description of the onscreen buttons:

- <Add> use to navigate to the **-Add Switch to Area-** screen
- <Delete> use to delete the highlighted button
- <Details> use to navigate to the **-Area Details-** screen
- <Relays> use to navigate to the **-Relays-** screen
- <OCC> use to navigate to the **-Occupancy Sensors-** screen
- <PC> use to navigate to the **-Photocells-** screen

**Step 4.23**

The Off DS button will turn Off the zone. The light level will dim to zero output and turn off the relay. The **-Relay / Group-** list will be populated with the corresponding controlled relays or groups.

Understanding the Screen

Ignore the settings of **-Initial Level-**, **-Delay-** and **-Override-**.

Description of the onscreen buttons:

- <OK> save the selections made and return to the **Switches** list screen.
- <Cancel> use to discard entries and return to previous screen

**Step 4.24**

Use the instructions outlined in Steps 4.5 through 4.7 to assign Relay 01 to the control of the Switch Button. To remove it, highlight the relay in the **-Assigned-** list and press the Left arrow button of the navigation keypad. The relay will move back to the **-Available-** list on the left side of the screen.

Understanding the Screen

Relay 01 of Panel 3 has is assigned to the Switch Button. No other relays are currently available in the Area.

Description of the onscreen buttons:

- <OK> use to accept entries and navigate to the **-Digital Switch Button Details-** screen

- Key
- <Add> On screen button.
- Name- Label of onscreen entry field
- NEXT Button on keypad
- Details Screen Name

**Step 4: Occupancy Sensor**

**Areas Details**

Description

Schedule

Areas

Details Relays Switches OCC PC

OK

**Occupancy Sensors**

Id	Description

Add Edit Delete

Details Relays Switches OCC PC

OK

**Add Occupancy Sensor to Area**

Id	Description
▶ 161	Ceiling Occupancy Sensor

Add Cancel

OK

**Step 5.1**

The Office Dimming Area requires occupancy sensors assigned to control of the relay. To add occupancy sensors to the Area, navigate to the <OCC> onscreen button and press OK.

Understanding the Screen

Description of the onscreen buttons:

- <Areas> use to navigate to the -Areas- list screen
- <Details> use to navigate to the -Area Details- screen
- <Relays> selecting this onscreen button will allow the addition/editing of assigned relays
- <Switches> selecting this onscreen button to add/edit assigned switches
- <PC> selecting this onscreen button to add/edit assigned Photocells

**Step 5.2**

The -Occupancy Sensors- screen lists the sensors assigned to the Area. This list will be displayed each time this section of the Area information is entered. The next step is to add these devices to the Area.

Understanding the Screen

Currently there are no occupancy sensors assigned to the Area.

Description of the onscreen buttons:

- <Details> use to navigate to the -Area Details- screen
- <Relays> use to navigate to the -Relays- screen
- <Switches> use to navigate to the -Switches- screen
- <PC> use to navigate to the -Photocells- screen

**Step 5.3**

The -Add Occupancy Sensor to Area- screen lists the available and yet unassigned occupancy sensors for the system. As an occupancy sensor is assigned to an Area, it is removed from this list.

Understanding the Screen

The highlighted occupancy sensor can be added to the Area by selecting the <Add> onscreen button.

Description of the onscreen buttons:

- <Cancel> use to navigate to the -Area Details- screen

- Key On screen button.
- <Add> Label of onscreen entry field
- Name- Button on keypad
- NEXT Screen Name

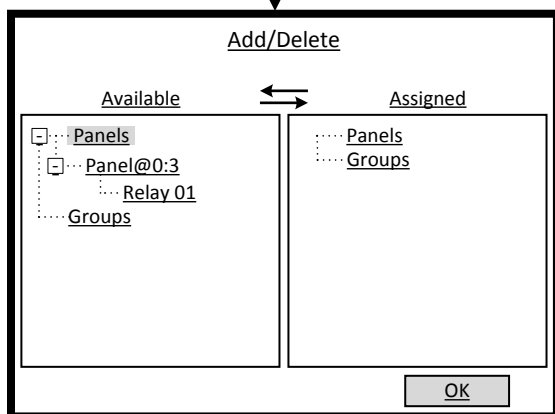
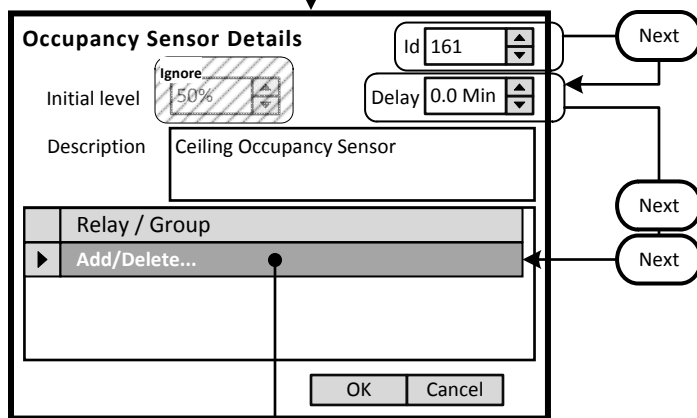
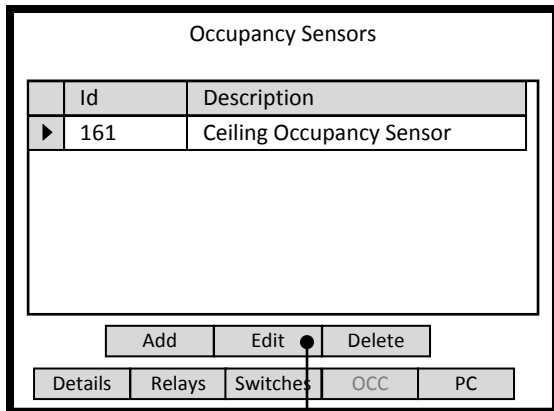

**Step 5.4**

The **-Occupancy Sensors-** screen lists the sensors assigned to the Area. This device must be configured and have one or more relays assigned to it. Highlight the desired occupancy sensor and navigate to the **<Edit>** button.

Understanding the Screen

Currently there is only one occupancy sensor assigned to the Area.

Description of the onscreen buttons:

- <Details> use to navigate to the **-Area Details-** screen
- <Relays> use to navigate to the **-Relays-** screen
- <Switches> use to navigate to the **-Switches-** screen
- <PC> use to navigate to the **-Photocells-** screen

**Step 5.5**

This screen configures the characteristics of the occupancy sensor.

The **-Delay-** setting is adjusted to provide a time delay after vacancy is determined by the sensor. The Off signal from the sensor will be received at the end of this delay period. The **-Relay / Group-** list will be populated with the corresponding controlled relays or groups.

Understanding the Screen

- The **-Description-** field can be edited on this screen.
- The **-Id-** can be changed.
- Ignore the settings of **-Delay-** and **-Initial Level-**.

**Step 5.5**

The left side of the screen under the heading **-Available-** lists all of the relays that have been assigned to an Area. If the desired relay is not on this list it has not been assigned to this Area. Relays are displayed according to the panel they are installed in. Use the navigation keypad to highlight the desired relay.

Understanding the Screen

Complete panels may be collapsed by highlighting name on the list pressing OK.

Description of the onscreen button:

- <OK> selecting this onscreen button will save the selections made and return to the **Relays** list screen.

- Key On screen button.
- <Add> Label of onscreen entry field
- Name- Button on keypad
- NEXT Screen Name

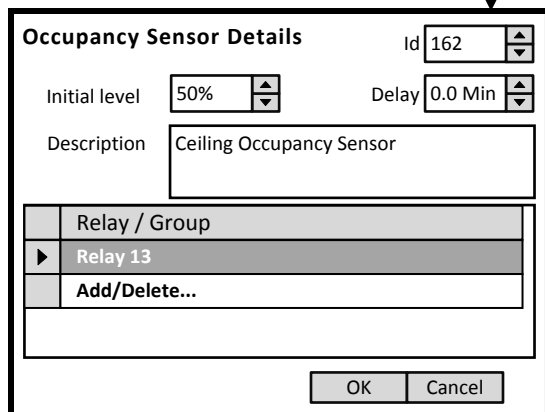
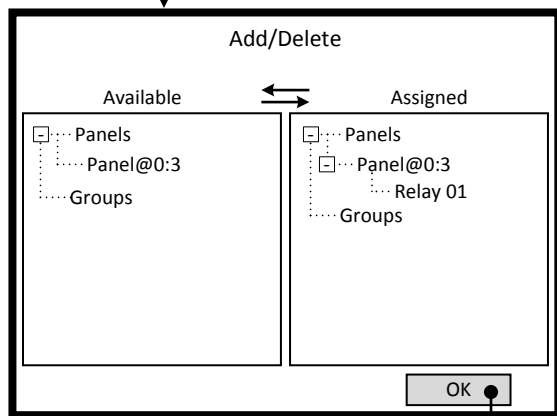
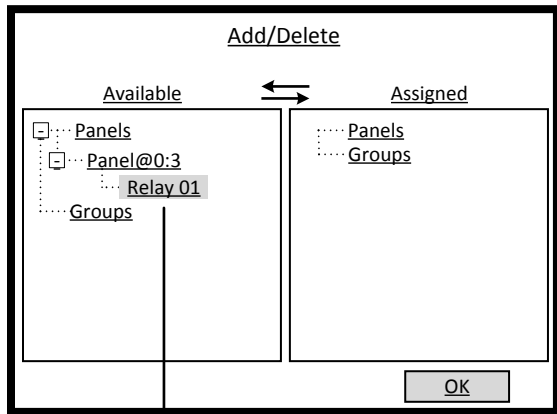

**Step 5.6**

Relays are assigned to the occupancy sensor by moving them from the **-Available-** list to the **-Assigned-** list. This is accomplished by highlighting the desired relay on the left side of the screen and using the right arrow to move it to the right side of the screen.

*Understanding the Screen*

Currently there are no relays assigned to this occupancy sensor.

Relay 01 of Panel 3 has been selected as a candidate for assignment to the occupancy sensor.

- Key <Add> On screen button.
- Name- Label of onscreen entry field
- NEXT Button on keypad
- Details Screen Name

Step 4: Photocell

Areas Details

Description

Schedule

Details
Relays
Switches
OCC
PC

OK

Photocells

Id	Type	Description

Details
Relays
Switches
OCC
PC

OK

Add Photocell to Area

Id	Type	Description
▶ 162	Closed Loop	

OK

**Step 6.1**

The Office Dimming Area requires a photocell assigned to control of the relay. The photocell is mandatory for Behaviors that involve a photocell in their control scheme. To add a photocell to the Area, navigate to the <PC> onscreen button and press OK.

Understanding the Screen

Description of the onscreen buttons:

- <Areas> use to navigate to the -Areas- list screen
- <Details> use to navigate to the -Area Details- screen
- <Relays> selecting this onscreen button will allow the addition/editing of assigned relays
- <Switches> selecting this onscreen button to add/edit assigned switches
- <OCC> selecting this onscreen button to add/edit assigned occupancy sensors

**Step 6.2**

The -Photocell- screen lists the photocells assigned to the Area. This list will be displayed each time this section of the Area information is entered. The next step is to add these devices to the Area.

Understanding the Screen

Currently there are no Photocell assigned to the Area.

Description of the onscreen buttons:

- <Details> use to navigate to the -Area Details- screen
- <Relays> use to navigate to the -Relays- screen
- <Switches> use to navigate to the -Switches- screen
- <OCC> use to navigate to the -Occupancy Sensors- screen

**Step 6.3**

The -Add Photocell to Area- screen lists the available and yet unassigned photocells for the system. As an photocell is assigned to an Area, it is removed from this list.

Understanding the Screen

The highlighted photocell can be added to the Area by selecting the <Add> onscreen button.

Description of the onscreen buttons:

- <Cancel> use to navigate to the -Area Details- screen

- Key On screen button.
- <Add> Label of onscreen entry field
- Name- Button on keypad
- NEXT Screen Name
- Details

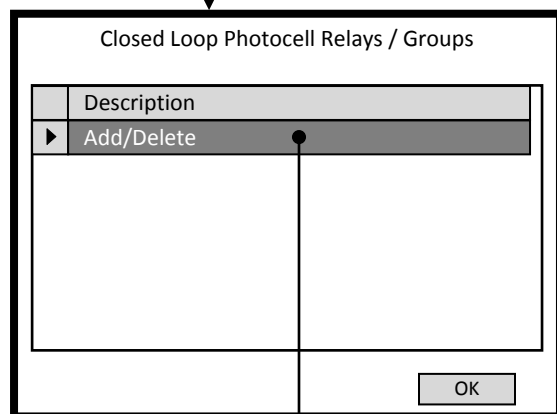
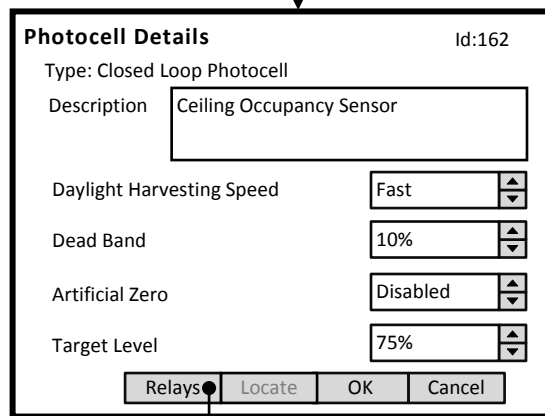
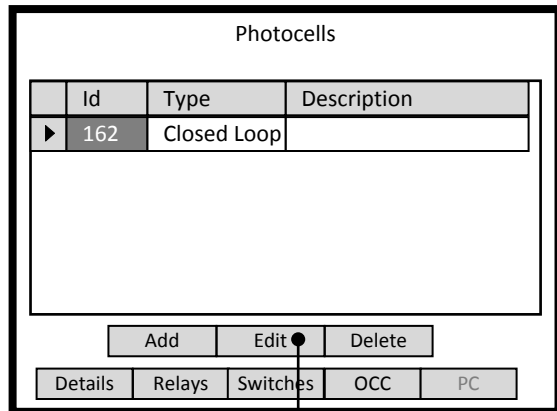

**Step 6.4**

The **-Photocells-** screen lists the photocell assigned to the Area. This device must be configured and have one or more relays assigned to it. Highlight the desired photocell and navigate to the **<Edit>** button.

Understanding the Screen

Currently there is only one photocell assigned to the Area.

Description of the onscreen buttons:

- <Details> use to navigate to the **-Area Details-** screen
- <Relays> use to navigate to the **-Relays-** screen
- <Switches> use to navigate to the **-Switches-** screen
- <OCC> use to navigate to the **-Occupancy Sensor-** screen

**Step 6.5**

This screen configures the characteristics of the Closed Loop Photocell. The **-Daylight Harvesting Speed-** setting is the speed of response to measured changes in light level. The **-Dead Band-** setting is applied to the target level to reduce sensitivity of the system relative to the target level. The **-Artificial Zero-** can be used to change the percentage of output of the relay that represents the off value . The **-Target Level-** is the desired light level in the space. This is the percentage of measured signal at the input terminals.

Understanding the Screen

The **-Description-** field can be edited on this screen.

**Step 6.6**

This is a list of the assigned Relays or Groups in the Area. Use the navigation keypad to highlight the desired relay or option. Pressing the OK button with the highlight as shown, will advance to the **Add/Delete** screen

Understanding the Screen

No Relays or Groups are assigned to the photocell .

Description of the onscreen button:

- <OK> selecting this onscreen button will save the selections made and return to the **Photocell Details** screen.

- Key
- <Add> On screen button.
- Name- Label of onscreen entry field
- NEXT Button on keypad
- Details Screen Name

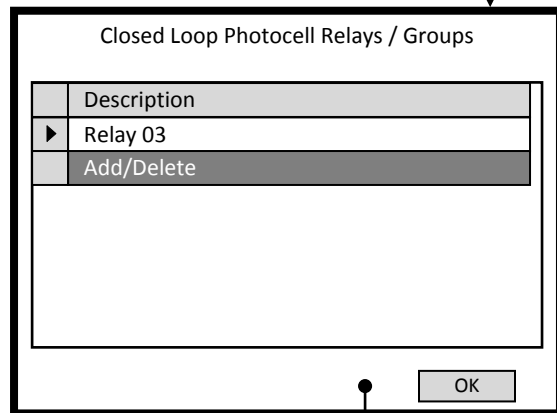
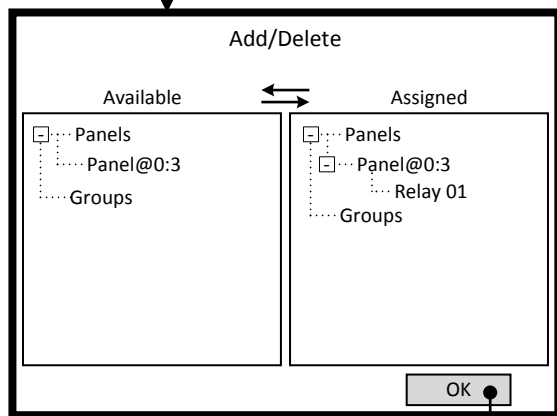
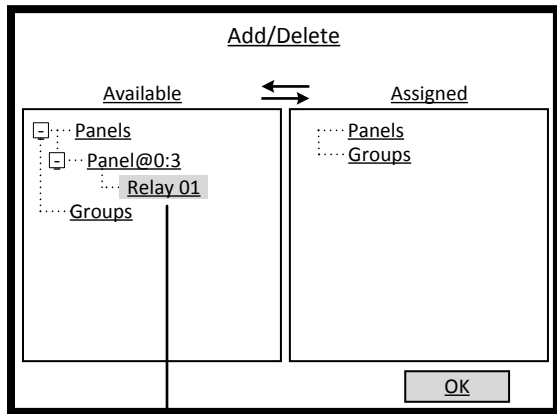

**Step 6.7**

Relays are assigned to the Photocell by moving them from the **-Available-** list to the **-Assigned-** list. This is accomplished by highlighting the desired relay on the left side of the screen and using the right arrow to move it to the right side of the screen.

Understanding the Screen

Currently there are no relays assigned to this occupancy sensor.

Relay 01 of Panel 3 has been selected as a candidate for assignment to the occupancy sensor.

**Step 6.8**

Relays are assigned to the Photocell by moving them from the **-Available-** list to the **-Assigned-** list. This is accomplished by highlighting the desired relay on the left side of the screen and using the right arrow to move it to the right side of the screen.

Understanding the Screen

Currently relay 01 of Panel 3 has been assigned to the photocell.

**Step 6.9**

This is a list of the assigned Relays or Groups in the Area. Use the navigation keypad to highlight the desired relay or option. Pressing the OK button with the highlight as shown, will advance to the **Add/Delete** screen. This completes the set-up. Press HOME or follow the string of OK buttons back to the **Area** list.

Understanding the Screen

Only one Relay is assigned to the photocell .

Description of the onscreen button:

<OK> selecting this onscreen button will save the selections made and return to the **Photocell Details** screen.



# Section 3

## Support Information

## Definitions

Agenda	A pattern of Behaviors or list of Behavior Transitions that cover a 24 hour period. Each Agenda provides a maximum of 24 transitions for that period. Time between Transitions can be as short as one minute apart.
Behavior	A predefined control scheme that, when applied to an Area, establishes the interactive priorities among the input devices in that Area. Certain behaviors can change device settings at the time of Transition. The system will stay in the last Behavior until the next Transition is triggered.
Behavior Transition	A point in time that an Agenda triggers an operational change to new Behavior. The transition will only occur in an Area that is assigned to the schedule.
Exceptions Calendar	This is a list of dates that requires specific Agenda that is a departure from the scheduled default Agenda. For example, a list of Holidays that require a unique Agenda.
Schedule	This is a series of seven Agendas corresponding with the days of the week. It is the fundamental or default week that will routinely function. Agendas for dates listed on the Exceptions Calendar will override the default Agenda for that day.
Low Voltage Inputs	Devices that interface with the controlled environment to detect the presence or absence of conditions or people. Devices include occupancy sensors, photocells, low voltage switches, and contact closures. These devices connect to a port on the Low Voltage input card and operate at +24vdc. The input signals from the devices are measured at 0 to +10vdc and can be analog or binary.
Analog Input	This is a signal from a device that will vary in voltage directly proportional to devices' measured detection value. For example, a photocell is used to measure the light level in a space. Full range or maximum light level at the photocell will measure +10vdc and conversely no light level will be 0vdc.
Binary Input	This is a signal from a device that will only have two state or measured voltage levels. Typically these values will be +10vdc (full On signal) or 0vdc (Off signal). An occupancy sensor provides this type of signal, On when occupant is present or Off when no occupant is sensed.
Astronomical Clock	This timing feature tracks the Sunset and Sunrise in the Northern hemisphere as it seasonally changes. The times change or update on a weekly basis. This allows Behavior Transitions based on Sunset and Sunrise times. Offsets from these times are also programmable.
Time/Date Clock	This is the main system clock used to coordinate all Behavior Transitions.

## Definitions

Digital Switch	A manual control switch station that connects to the system via the LumaCan network. They are available in one, two, and four button configurations. Each button on the Digital Switch is programmable for a variety of functions and features.
LumaCan	This is the communication network platform that interconnects all components in the system.
Low Voltage Input Board	This board provides the connection of Low Voltage devices to the system. This board is available in two sizes, 8 and 16 independent inputs.
Closed Loop Photocell	This device measures the light in a specific space or area and provides a proportional signal to the input port. This device will typically measure the light on a surface. It is used to drive the system response for daylight harvesting functions. The light level measured will be the sum of natural and artificial light on the surface. A Target Level is the percentage of measured range that the measured light should maintain. The Closed Loop Photocell controls a single zone.
Open Loop Photocell	This device measures the light level of a source of natural light that is intended to illuminate an area. It should be mounted facing toward the light source as a glass Atrium or sky light. It will be used to vary the artificial light output proportionally to the intensity of the natural light. The Open Loop Photocell can be used to control up to 8 zones with varying degrees of dimming percentage.

### Photocell Signals and Calibration

There are several types of photocells available for connection to the GreenMAX system. All photocells must operate at +24VDC and provide an input signal proportional to the foot-candle value being measured. This input signal must range between 0 and +10VDC. The selected photocell must match the application range of measurement.

The chart on this page illustrates the relationship between foot-candles and percentage of scale. Notice the following items:

- The maximum of the range is 100%, minimum is 0%.
- Each type of photocell has a unique maximum range value.
- The proportional values through the signal range while maintaining the relationship between percentage, voltage, and foot-candles.

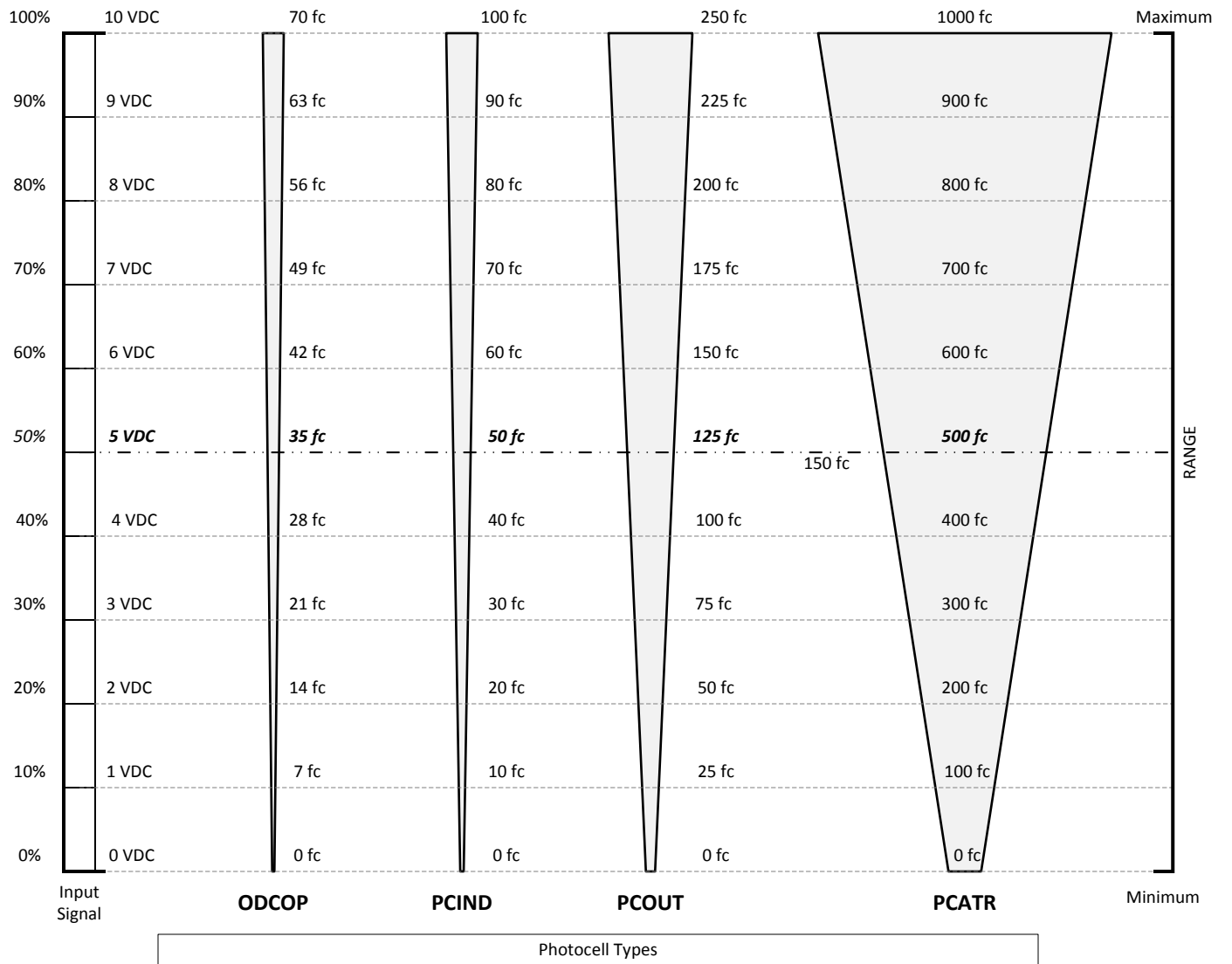

Low Voltage Connection Diagrams

Diagram 1 - Typical Occupancy Sensor Wiring

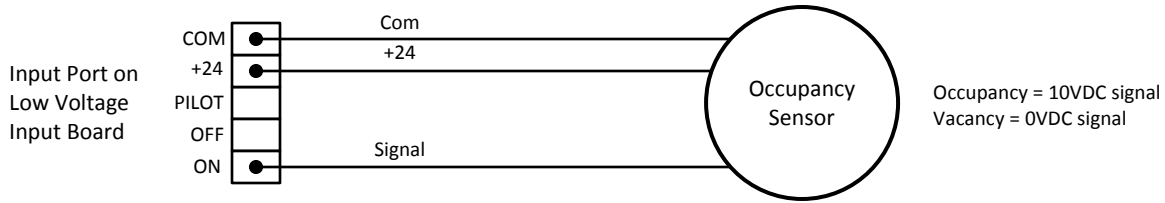
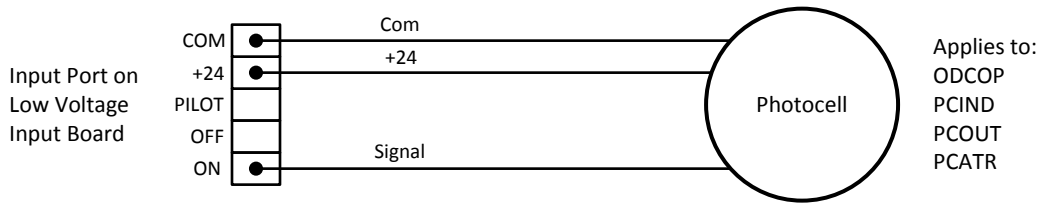
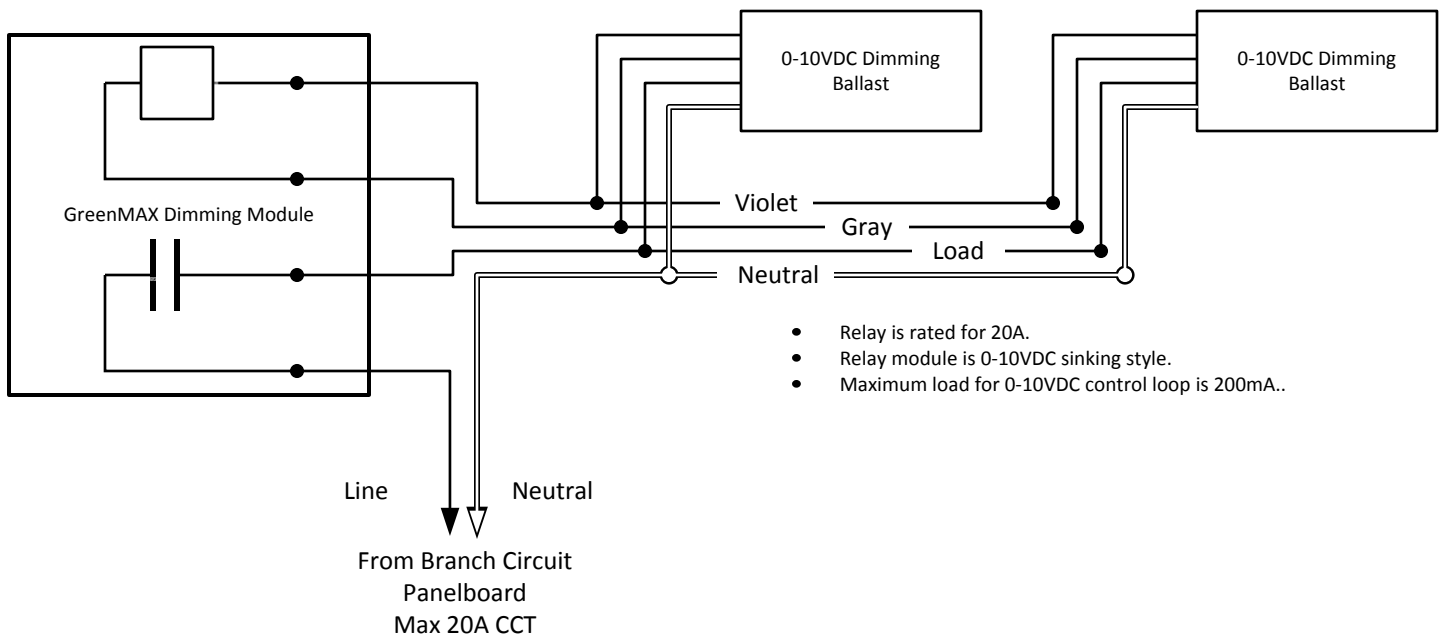

Diagram 2 - Typical Photocell Wiring



- Signal is proportional to measured value in the 0 to 10VDC range.
- Maximum foot-candle reading varies by model.

Diagram 3 - Typical Dimming Module Wiring



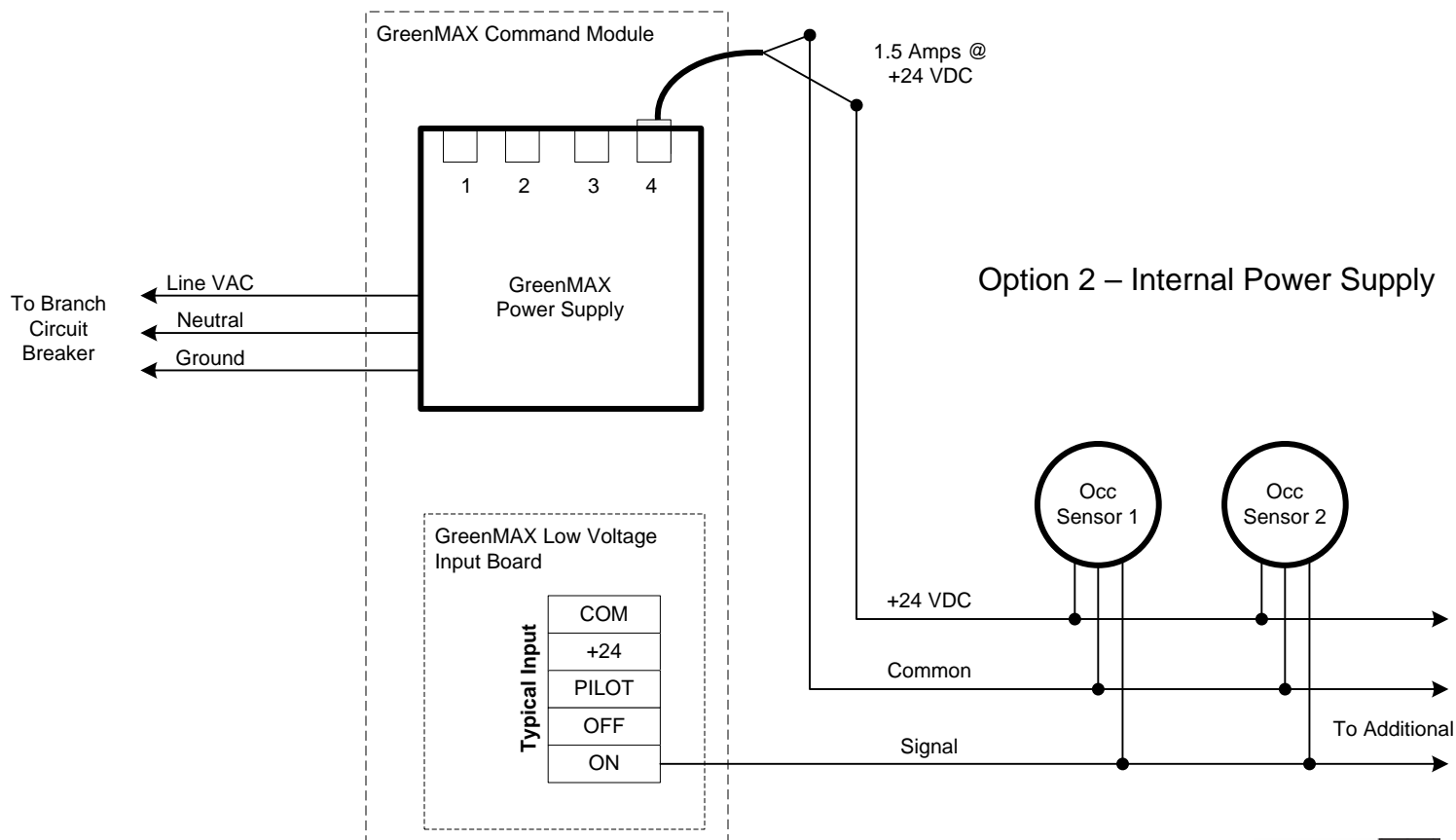
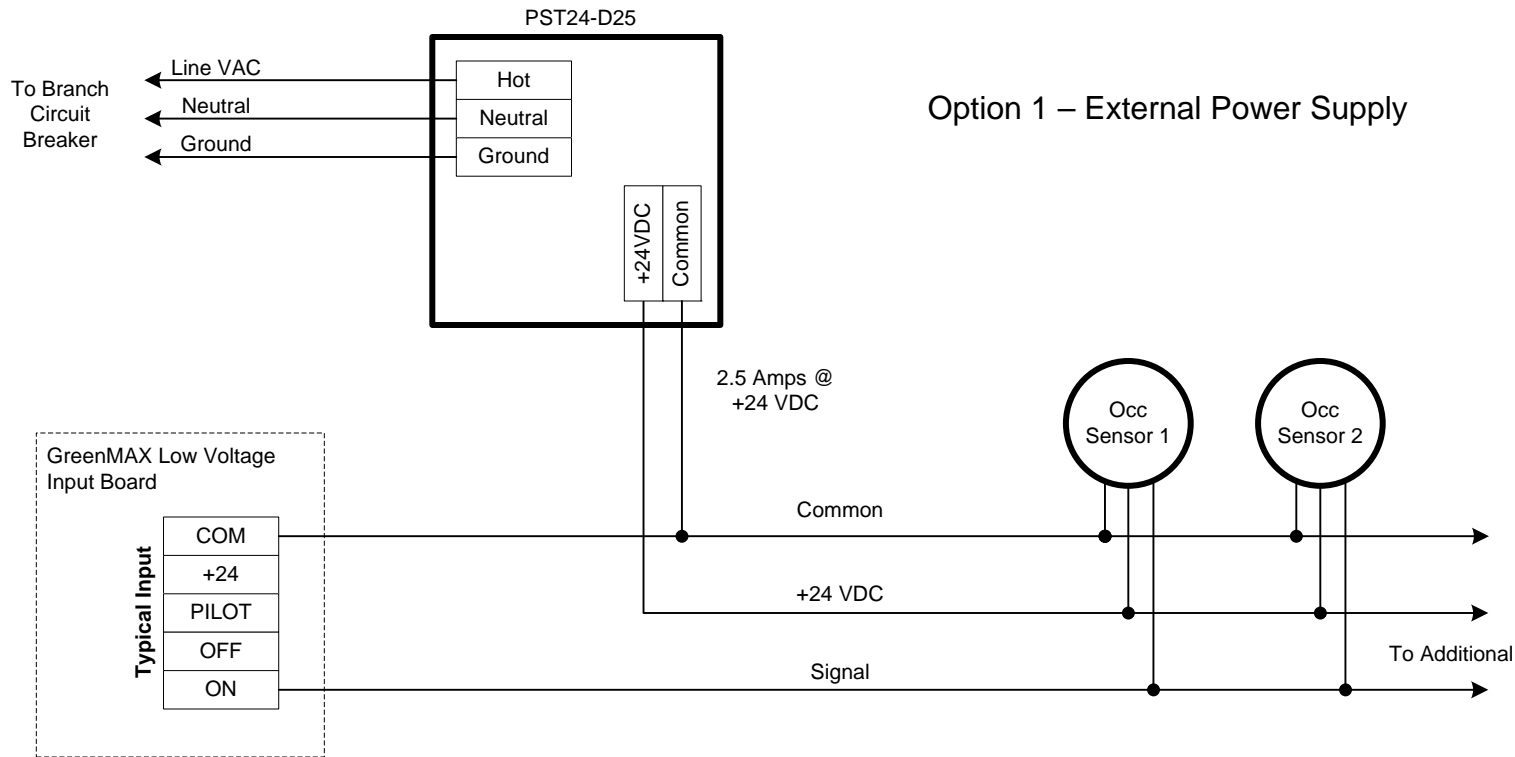



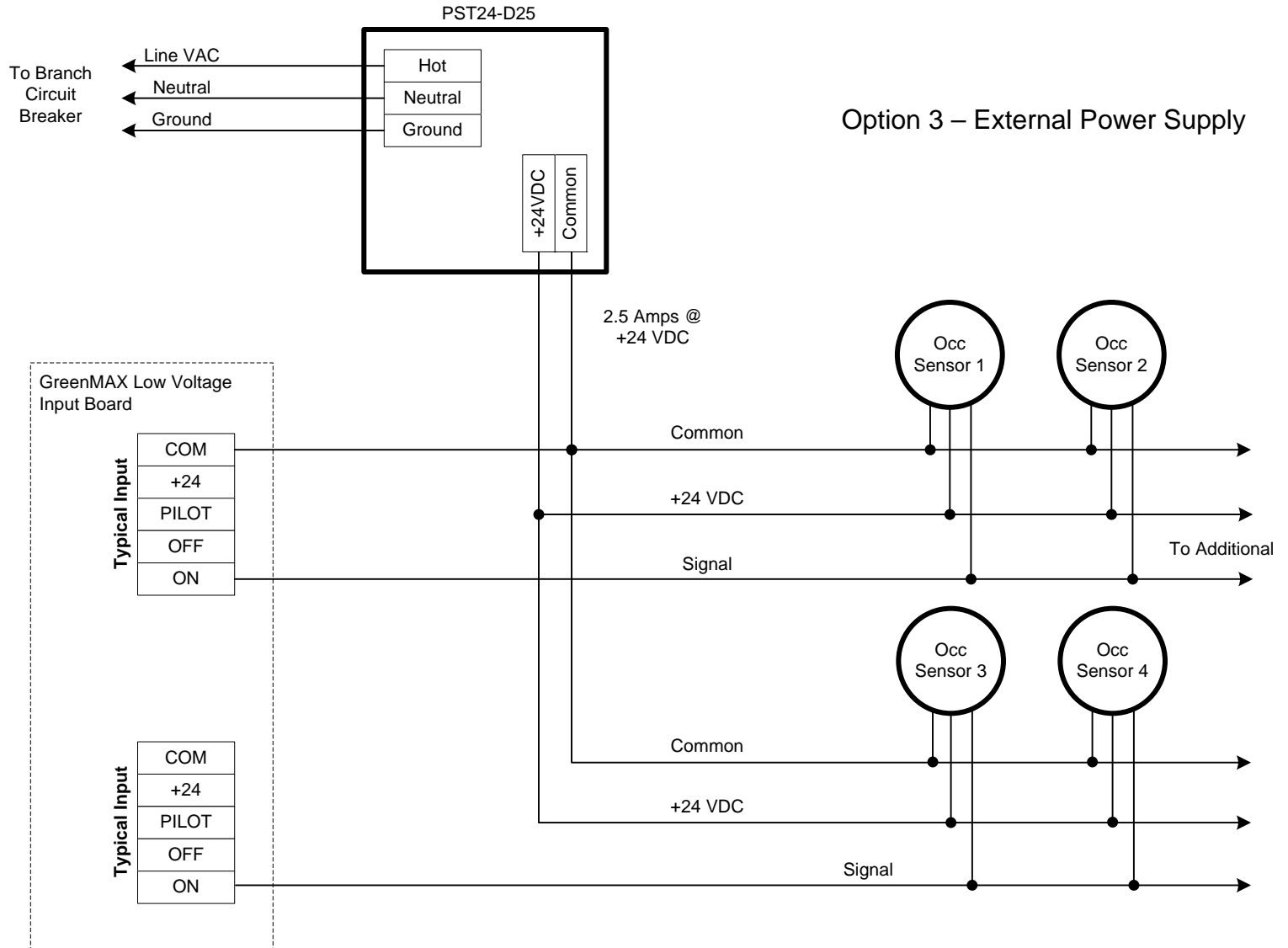





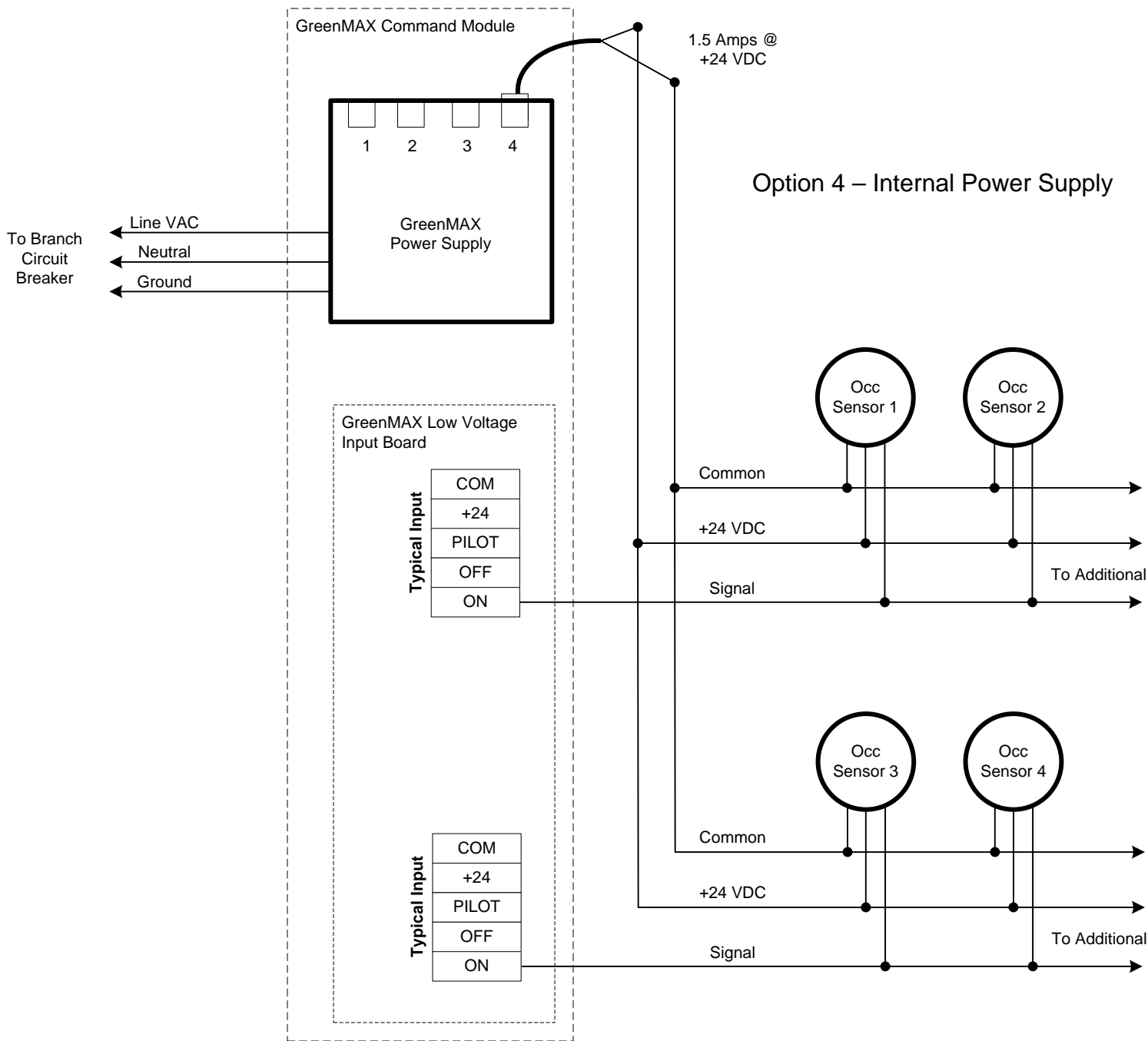



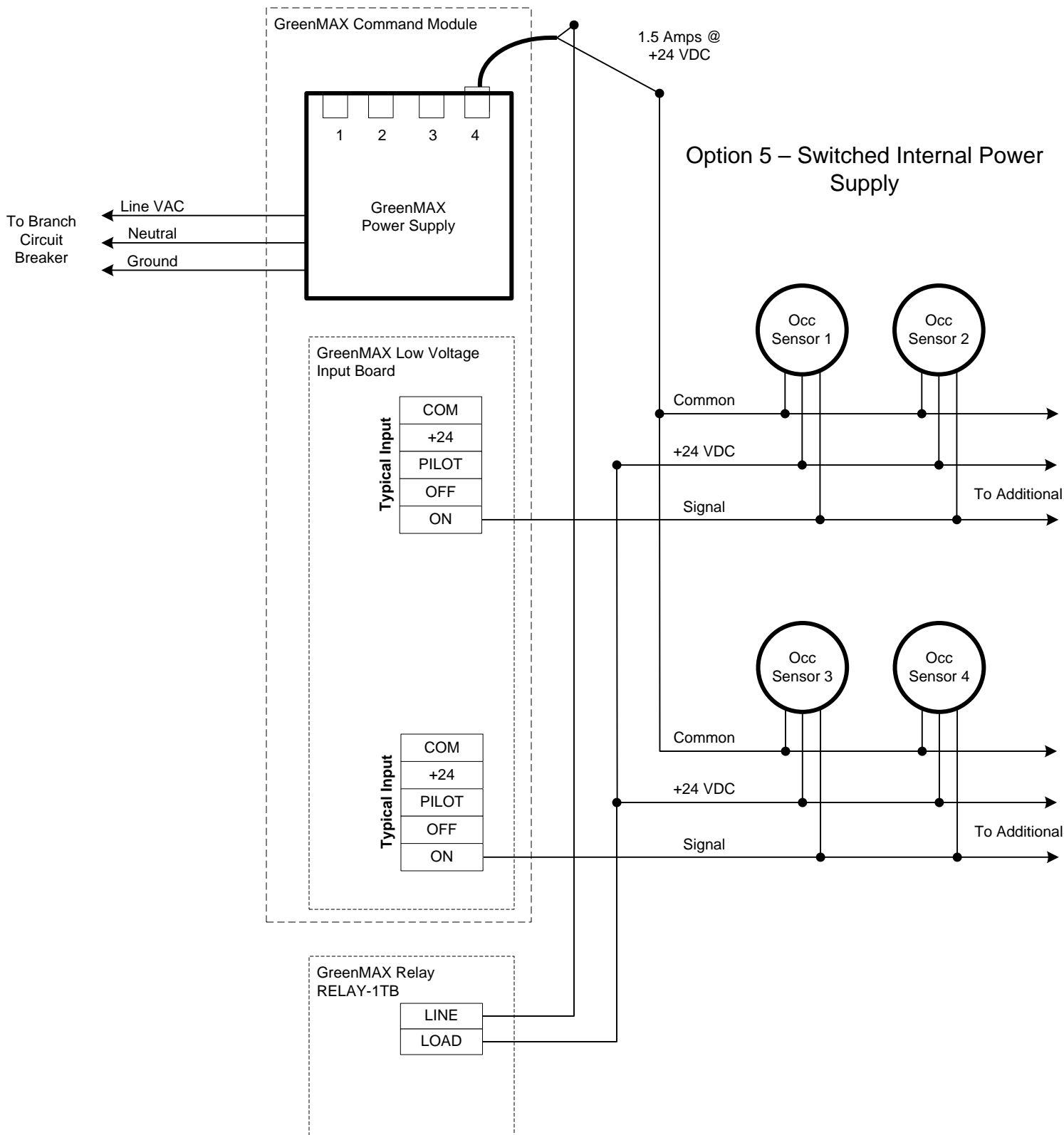



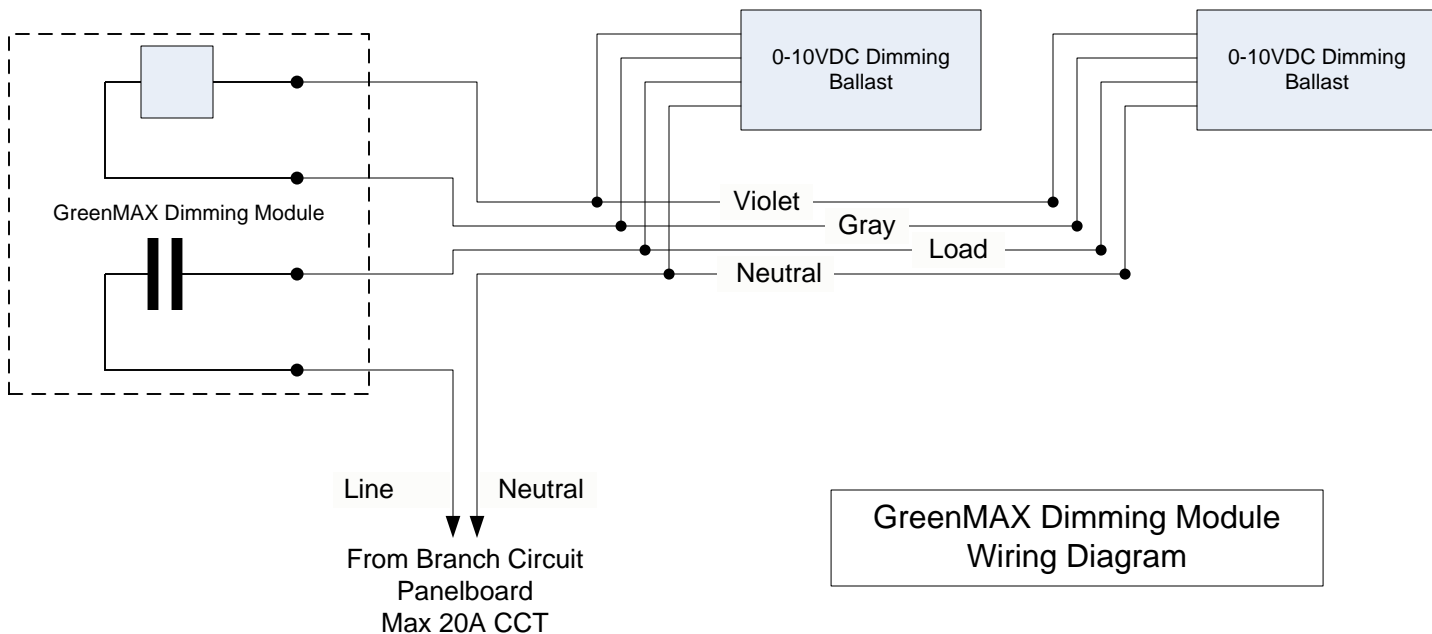
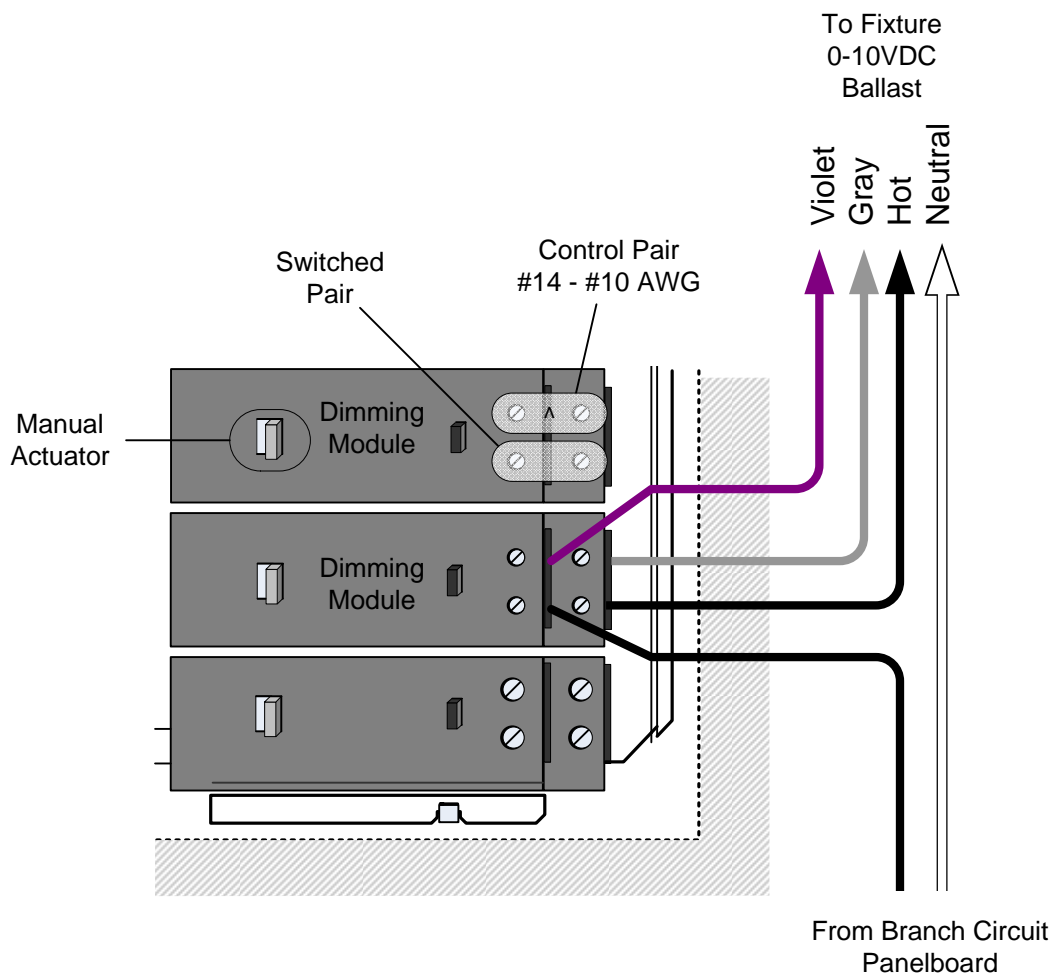



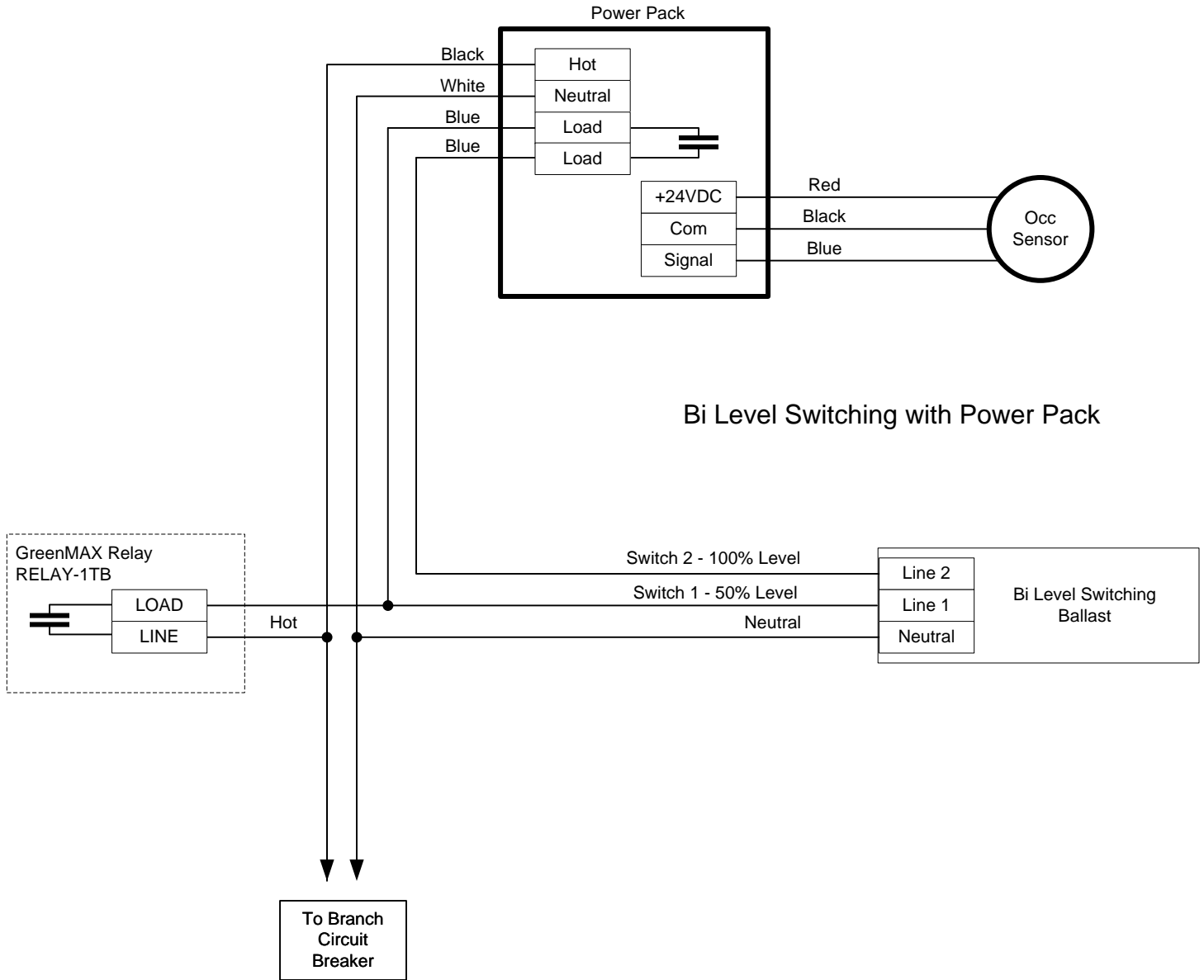





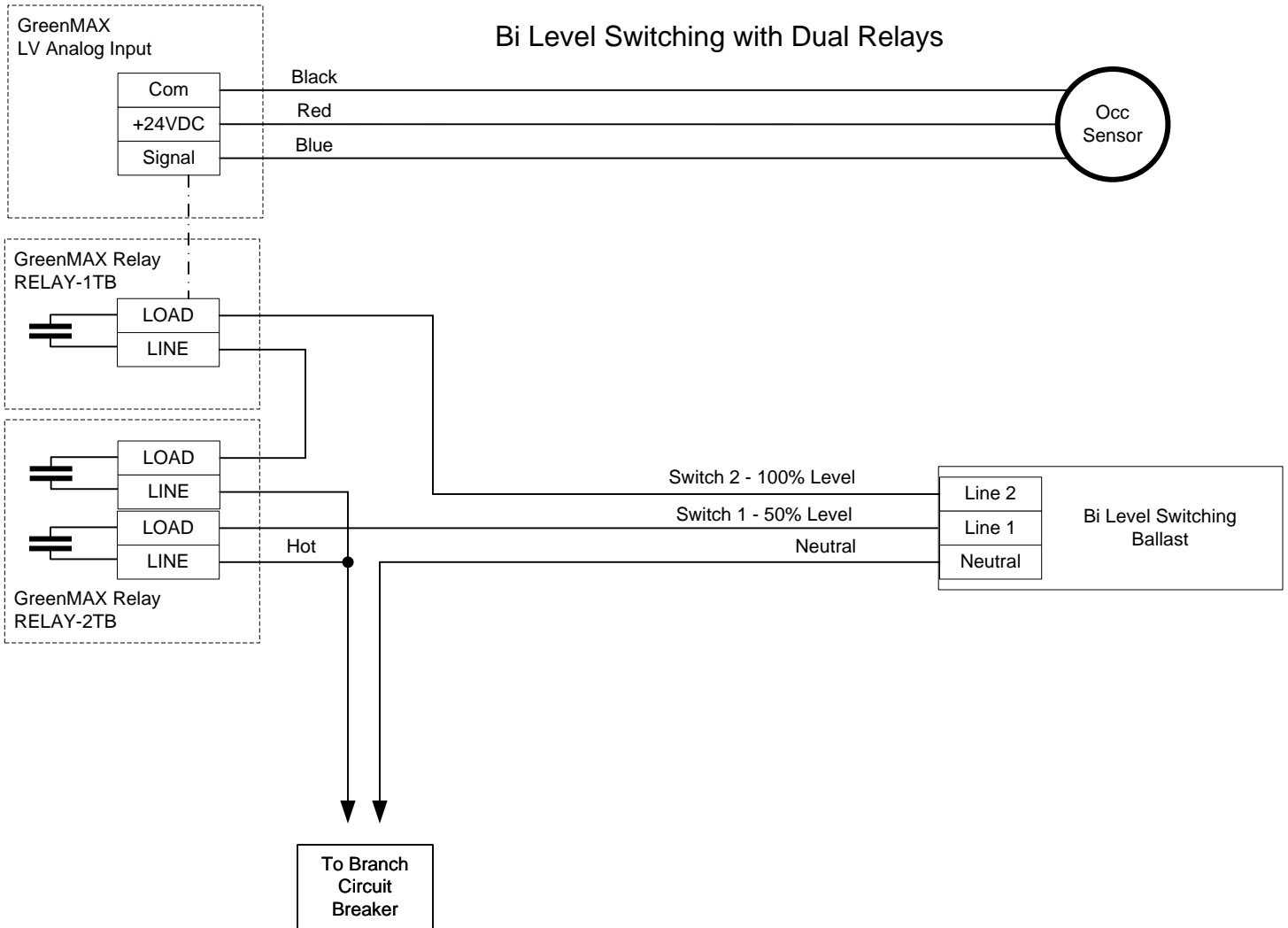



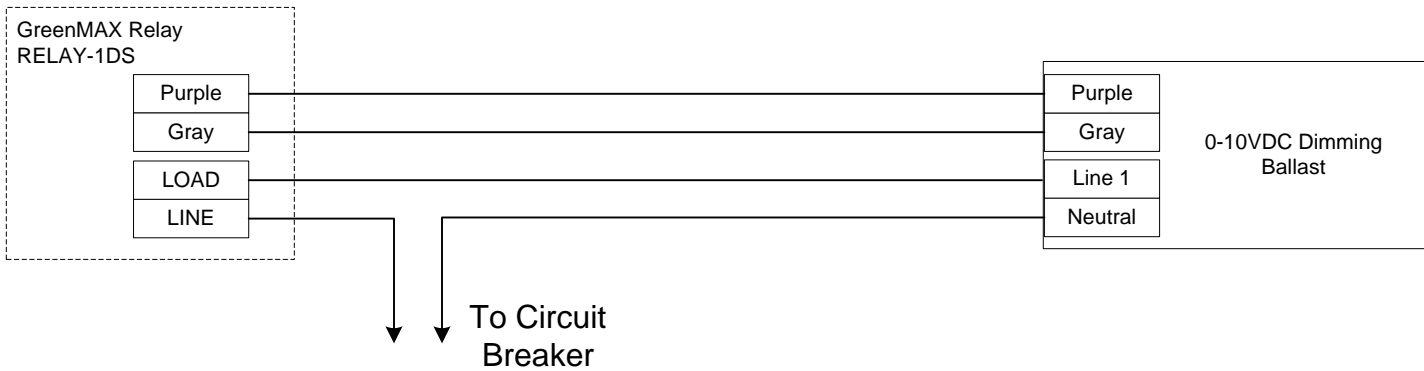
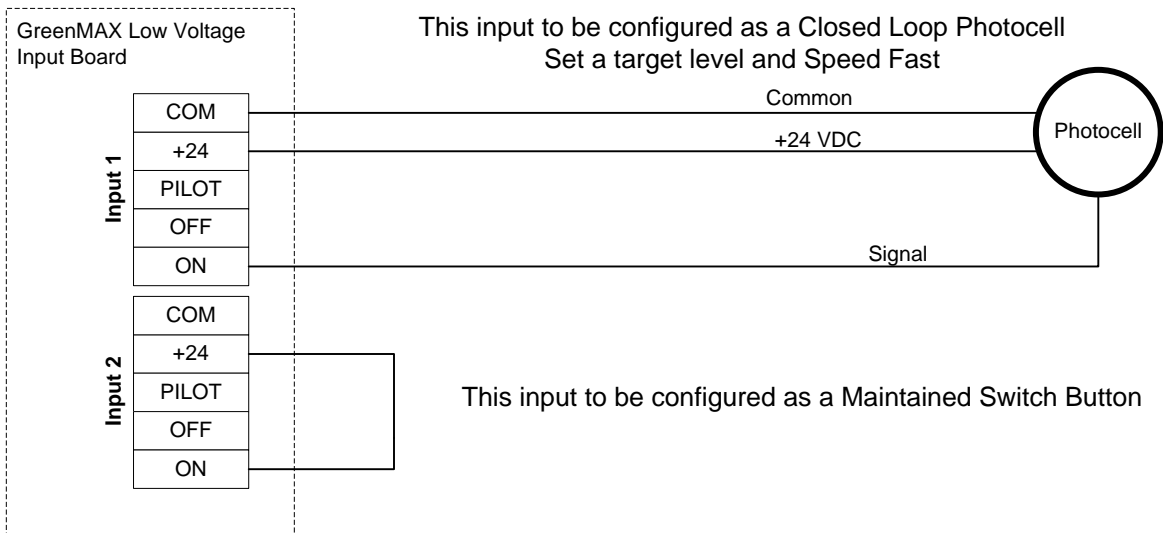

This will require 2 Areas:

Area 1 – Daylight Harvesting with RELAY 1DS and Inputs 1 and 2; running Agenda 1

Agenda 1

8:00AM B10 (start Daylighting)

5:00PM B7 off (turn OFF lights)



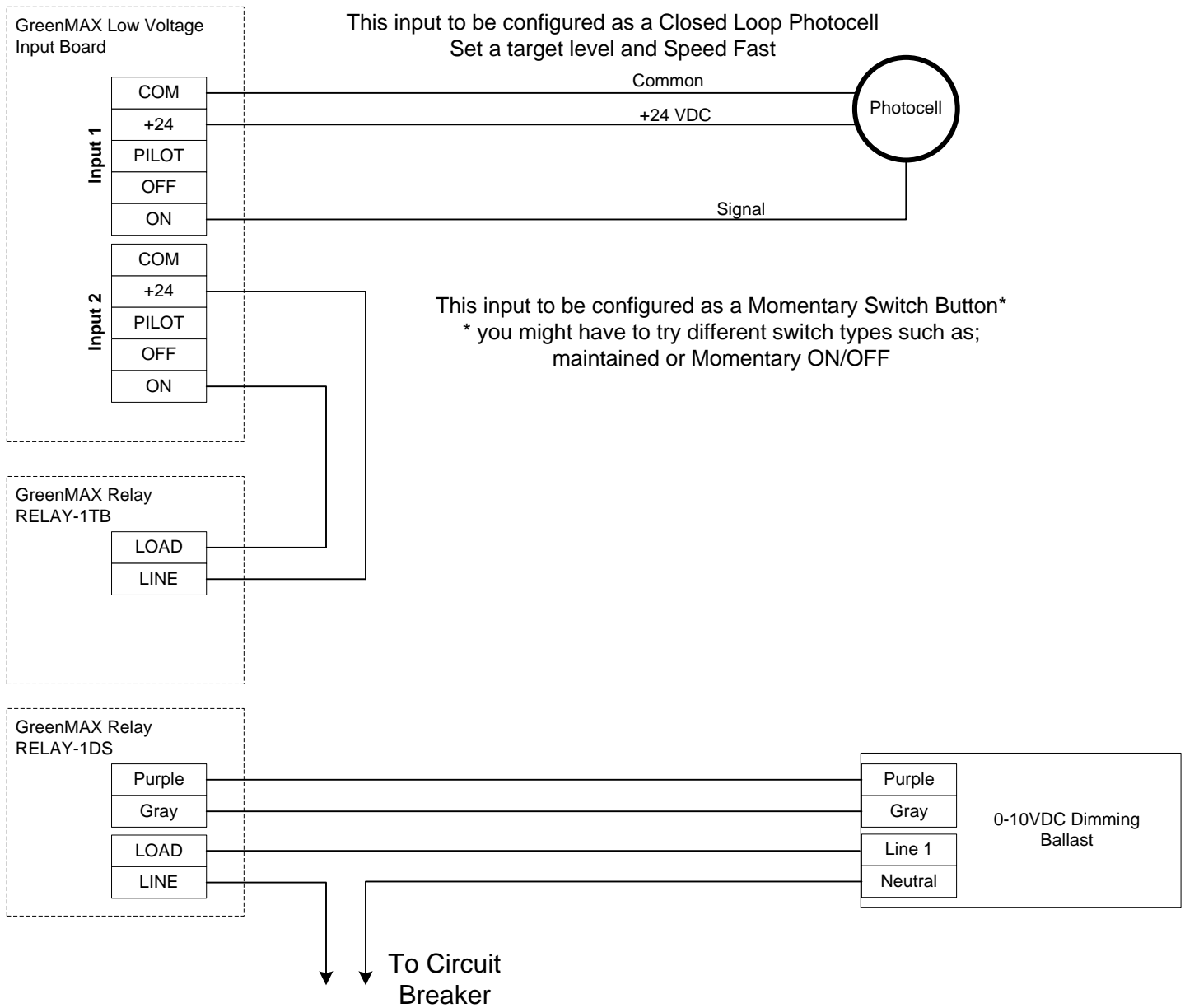

This will require 2 Areas:

Area 1 – Daylight Harvesting with RELAY 1DS and Inputs 1 and 2; running Agenda 1

Area 2 – Button Press control with RELAY 1TB; running Agenda 2

**Agenda 1**

8:00AM B10 (start Daylighting)  
 5:00PM B7 off (turn OFF lights)

**Agenda 2**

8:01AM B6 ON (makes a button press)  
 5:00PM B7 off (releases button press)

These agendas are staggered by one minute with daylighting starting first.



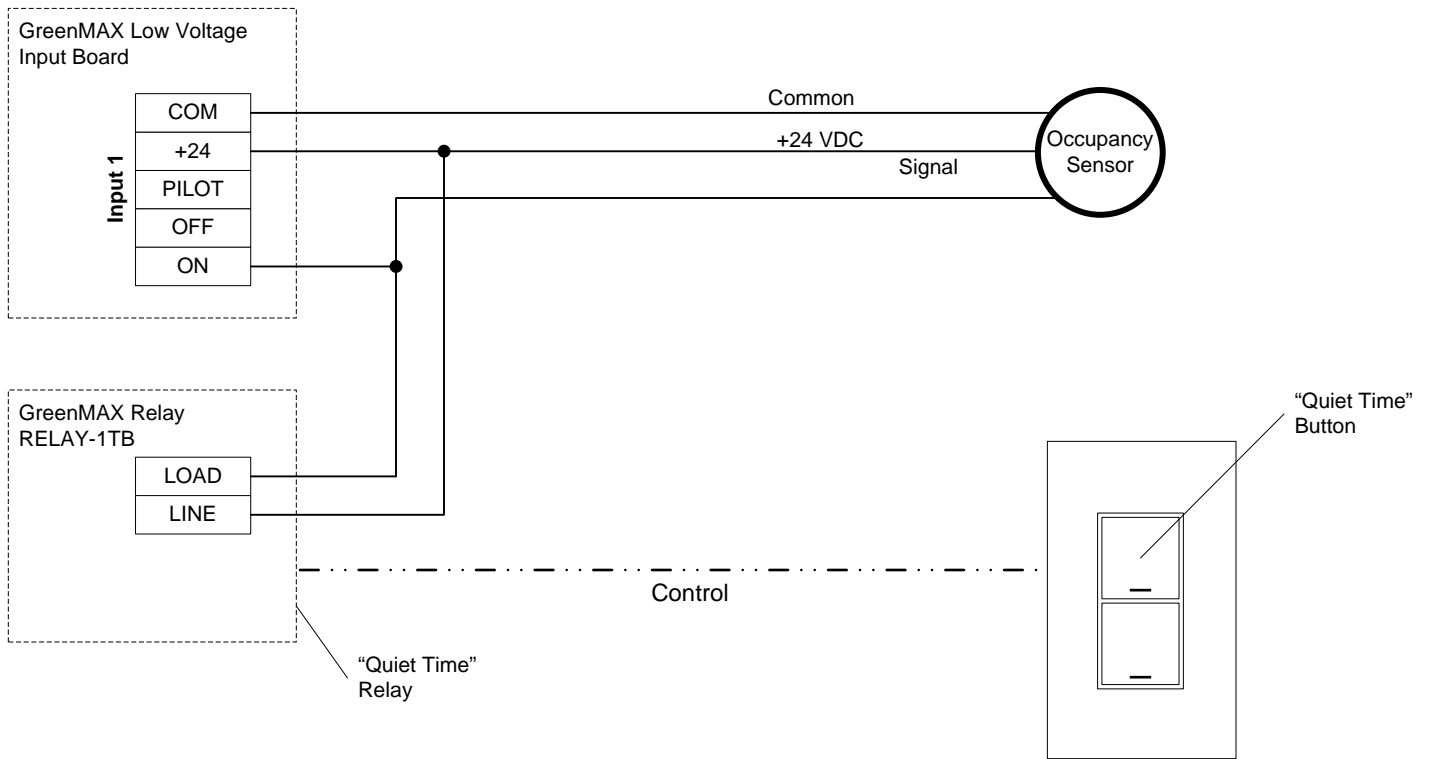

**Scheduling Items:**

The Quiet Time button will be programmed as a Timed Switch with a 2 hour delay. The relay will hold the occupied signal (On) of the occupancy sensor signal. This will prevent the Off signal from occupancy sensor from controlling the lights. At the end of the delay time, the relay will open and return the control to the occupancy sensor.





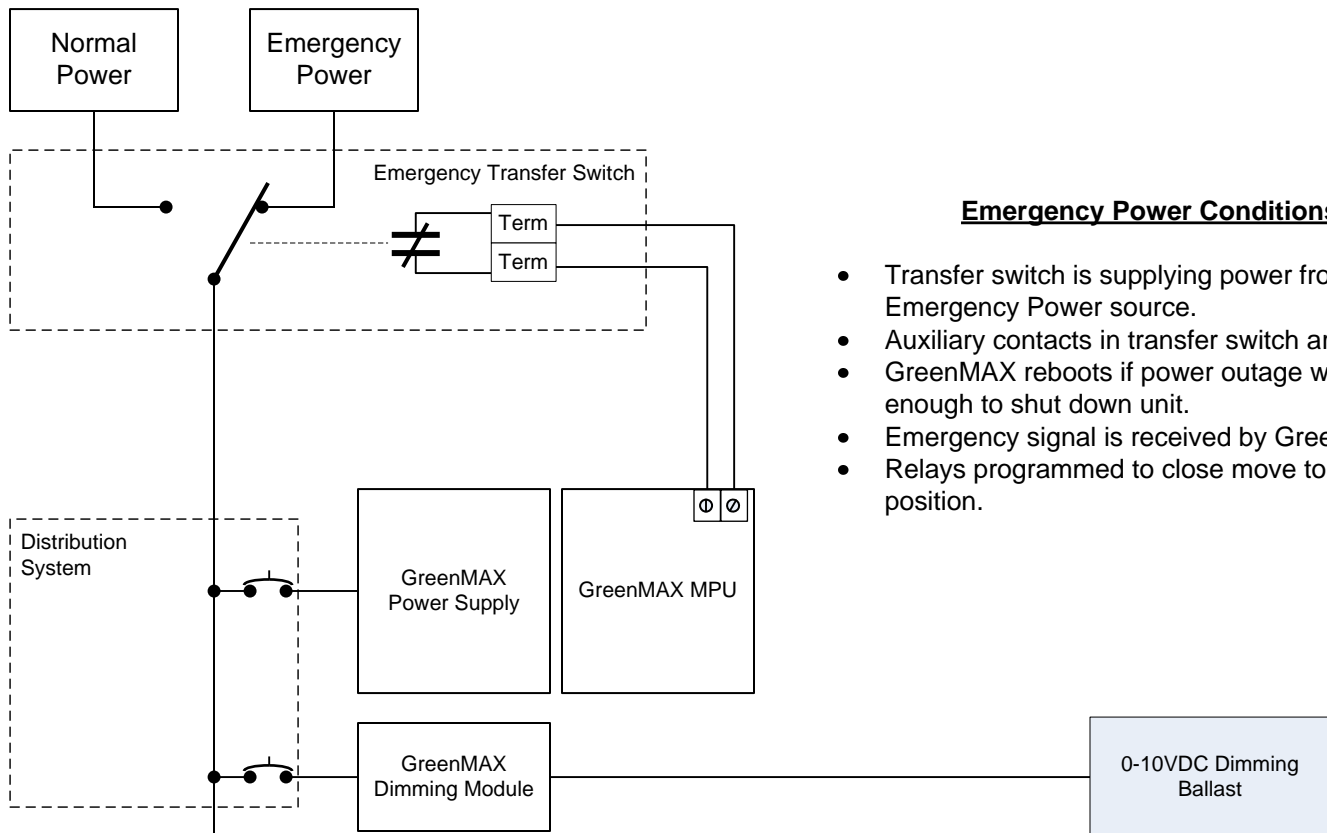
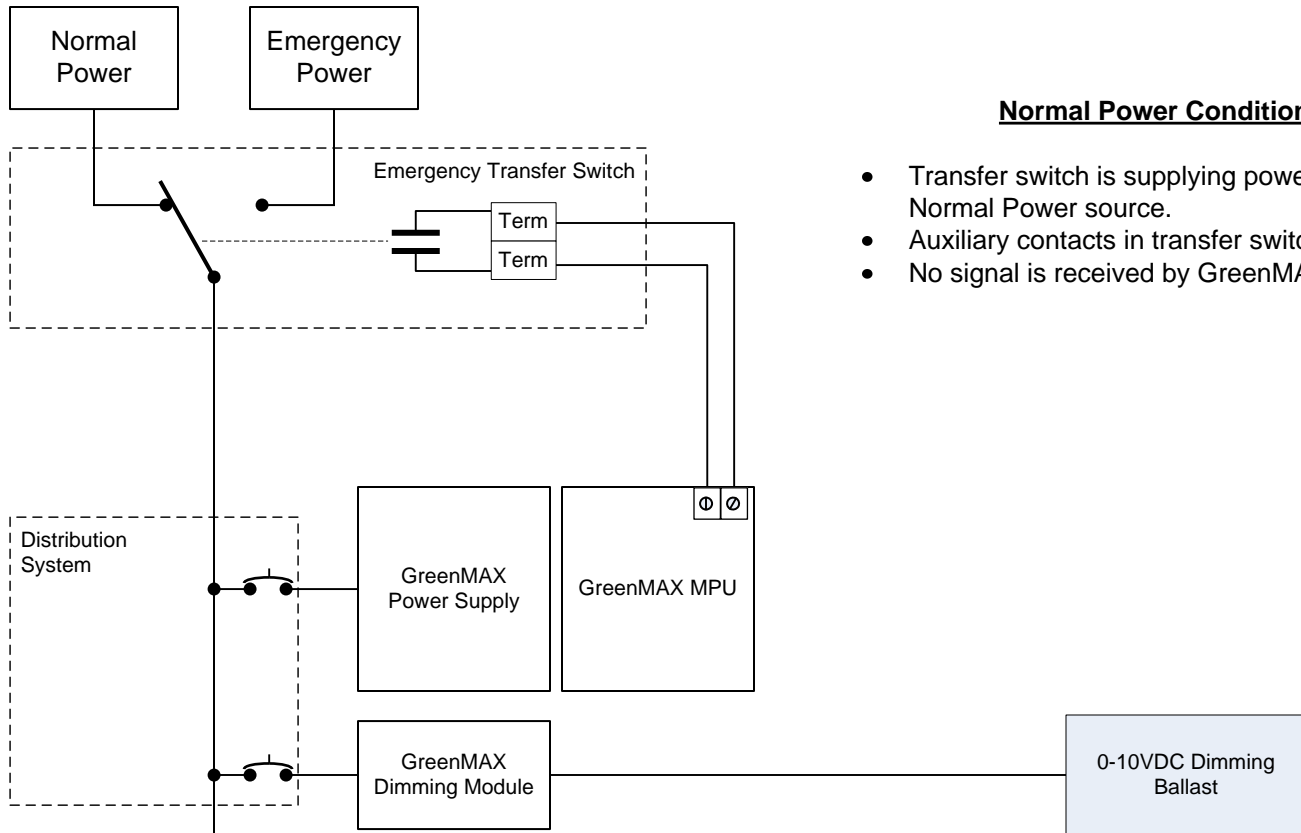



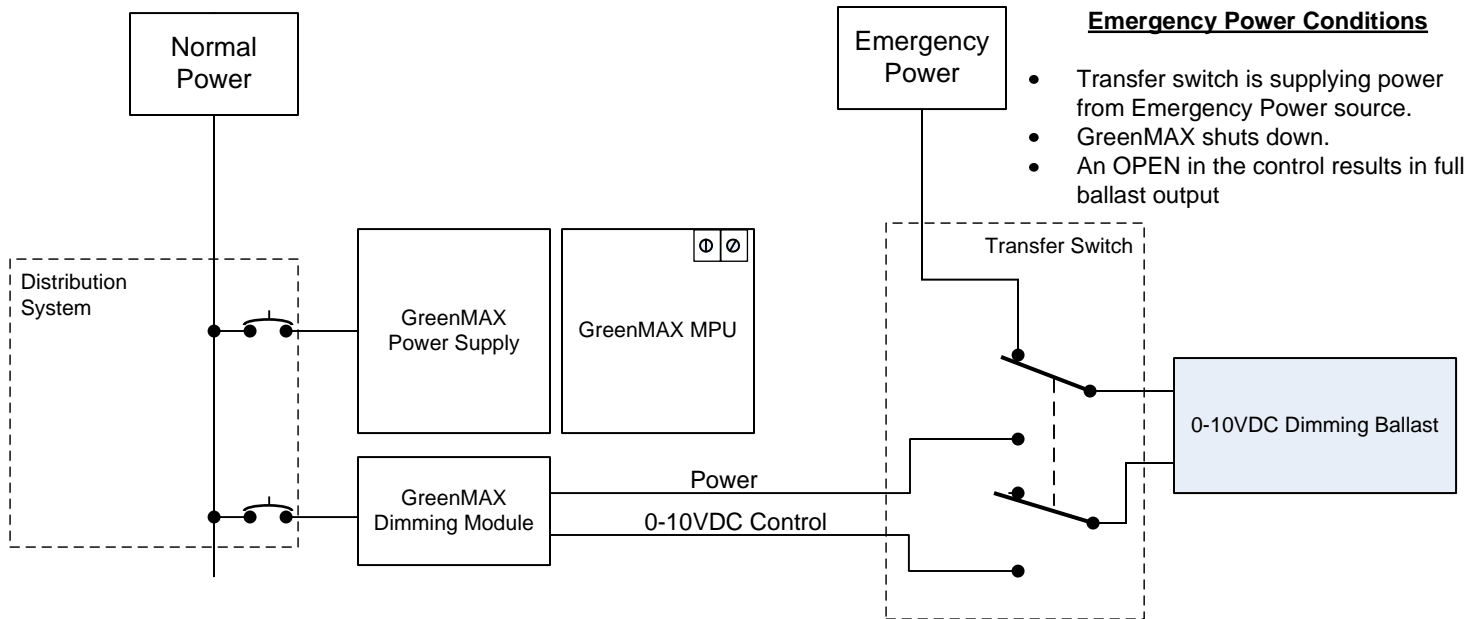
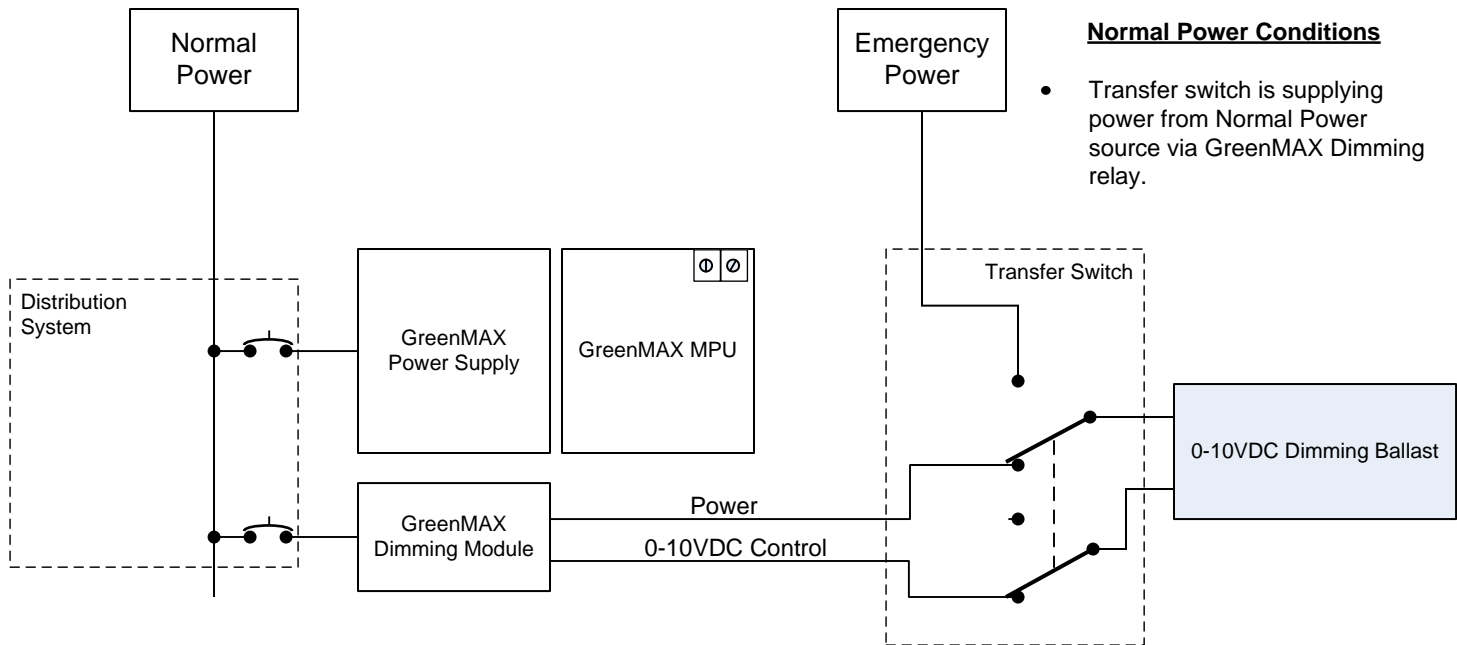



WIRING DIAGRAM

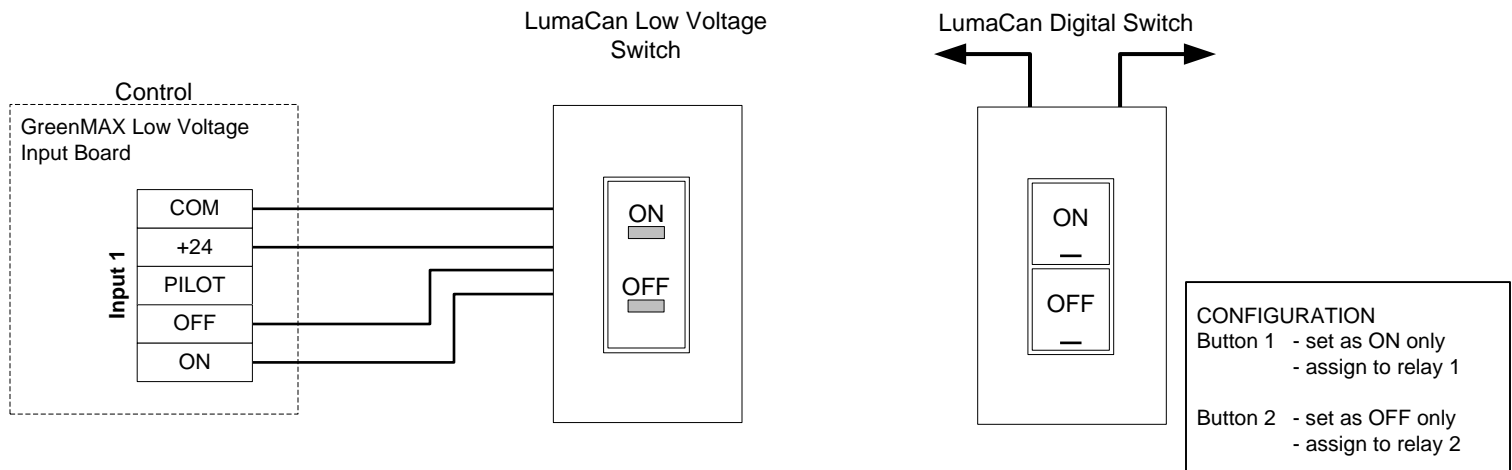
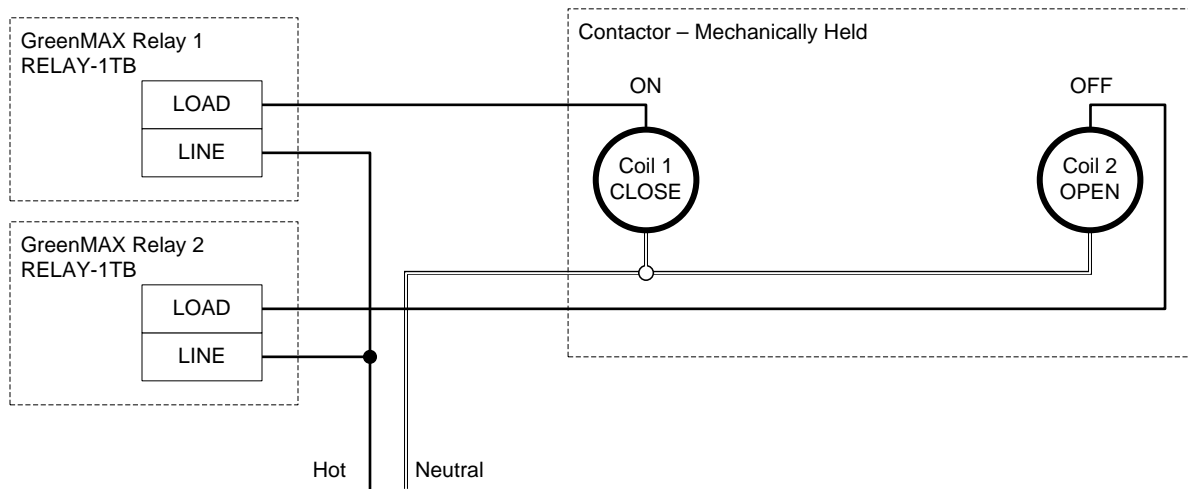

CONFIGURATION DETAILS

<b>Relay Details</b>		<b>Description</b>	
Number: 1		Relay 01	
Channel: 1			
Type: 1TB			
Ignore <input type="checkbox"/> Blink Warn Enabled BW Time: 0.5 Sec. BW Delay: 1 Min. BW Ovrd: 4 Min.		<input checked="" type="checkbox"/> Pulsed Relay <input checked="" type="checkbox"/> Normally Open <input checked="" type="checkbox"/> On: 5.0 Sec <input type="checkbox"/> Off: [ ] Sec Emergency: Ignore	
Prev	Next	Test	OK Cancel

<b>Description</b>	
Relay 02	
<input checked="" type="checkbox"/> Pulsed Relay <input checked="" type="checkbox"/> Normally Open <input type="checkbox"/> On: [ ] Sec <input checked="" type="checkbox"/> Off: 5.0 Sec Emergency: Ignore	
OK	Cancel

**RELAY CONFIGURATION**  
 After entering the configuration details shown, cycle the Normal/Override switch to push changes down to the relay. If this step is missed, no changes will take effect.



FUNCTIONAL DIAGRAM

**Behavior B6 - ON**

**Behavior B7 - OFF**

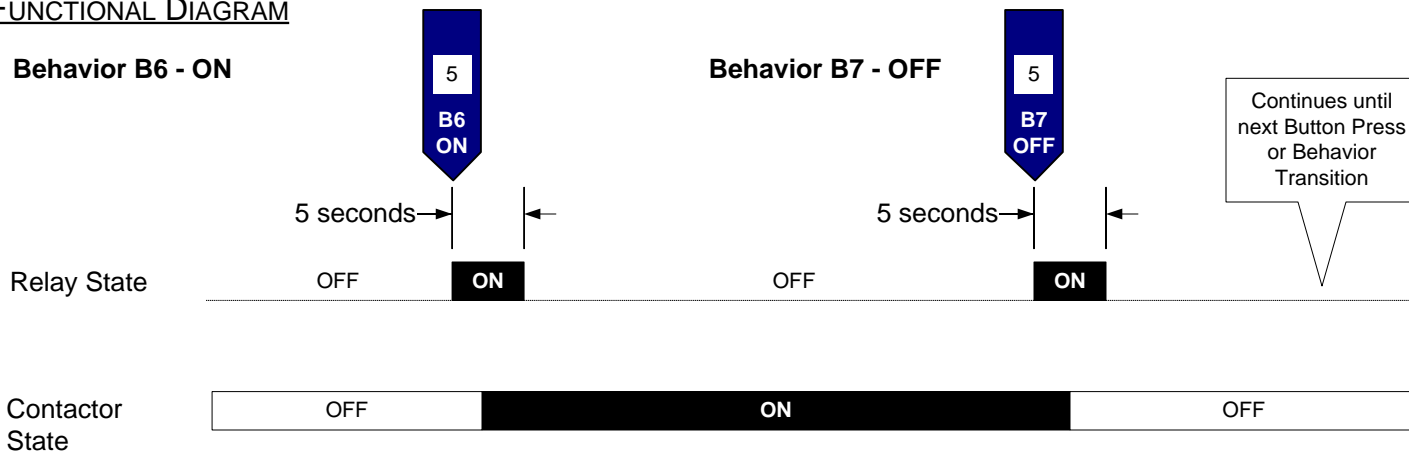

FUNCTIONAL DIAGRAM

**Behavior B4 – Switch Only**

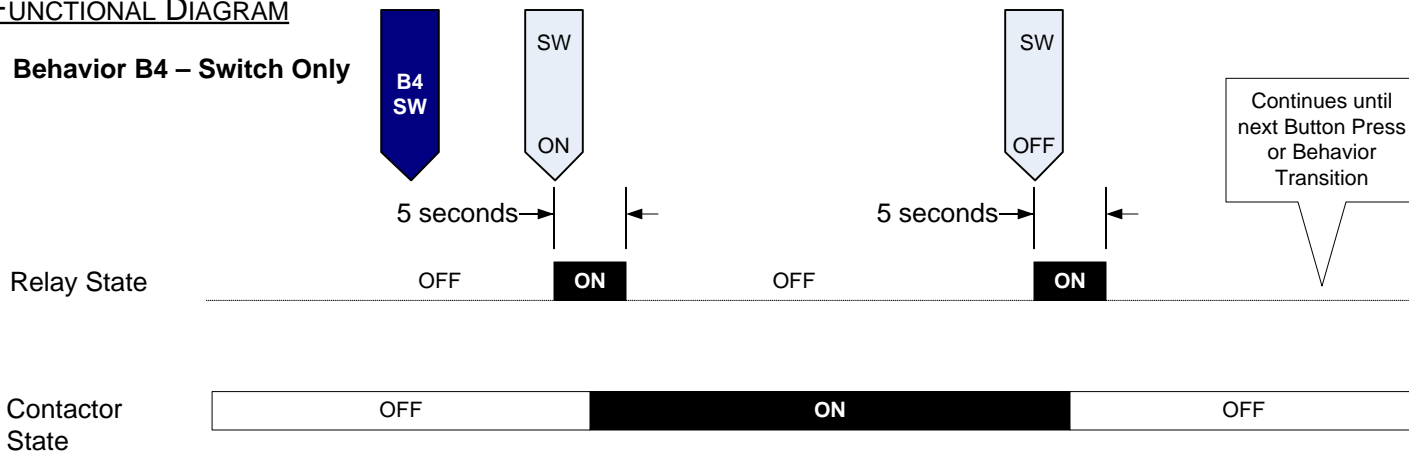





WIRING DIAGRAM

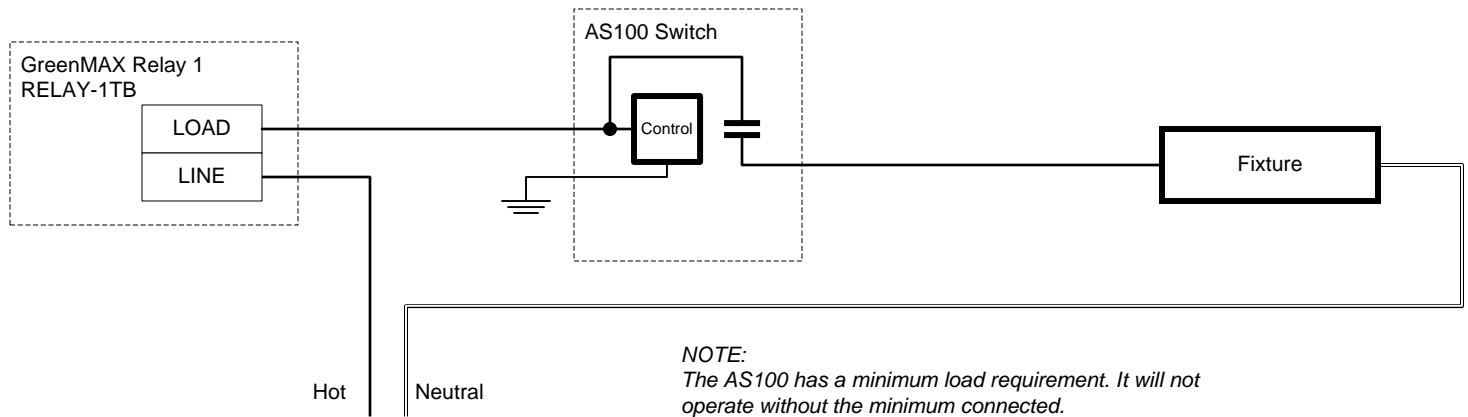

**NOTE:**  
 The AS100 has a minimum load requirement. It will not operate without the minimum connected.

CONFIGURATION DETAILS

<b>Relay Details</b>		<b>Description</b>	
Number: 1		Relay 01	
Channel: 1			
Type: 1TB			
<input type="checkbox"/> Ignore <input type="checkbox"/> Blink Warn Enabled		<input checked="" type="checkbox"/> Pulsed Relay <input type="checkbox"/> Normally Open	
BW Time: 0.5 Sec.		<input type="checkbox"/> On: [ ] Sec	
BW Delay: 1 Min.		<input checked="" type="checkbox"/> Off: 5.0 Sec	
BW Ovr: 4 Min.		Emergency: Ignore	
[ Prev ] [ Next ] [ Test ]		[ OK ] [ Cancel ]	

**PULSED RELAY**

When this box is checked the relay will:

- Respond to a Behavior B7 OFF with a short OFF pulse. The duration of the pulse is determined by the value in the OFF field.
- Respond to a Behavior B6 ON with a short OFF pulse. The duration of the pulse is determined by the value in the ON field.
- The relay will return to the closed position and maintain that position until the next scheduled Behavior B6 or B7.

**ON PULSE LENGTH**

AS100 NORMAL OPERATING MODE

3 Sec Turn ON

**OFF PULSE LENGTH**

AS100 NORMAL OPERATING MODE

1-2 Sec Delay OFF Initiates 5-minute delay before shutting load Off.  
 5 Sec Turn OFF

**NOTE:**  
 These settings will not be applied until the Normal/Override switch is cycled.

FUNCTIONAL DIAGRAM

**Behavior B7 - OFF**

**Behavior B6 - ON**

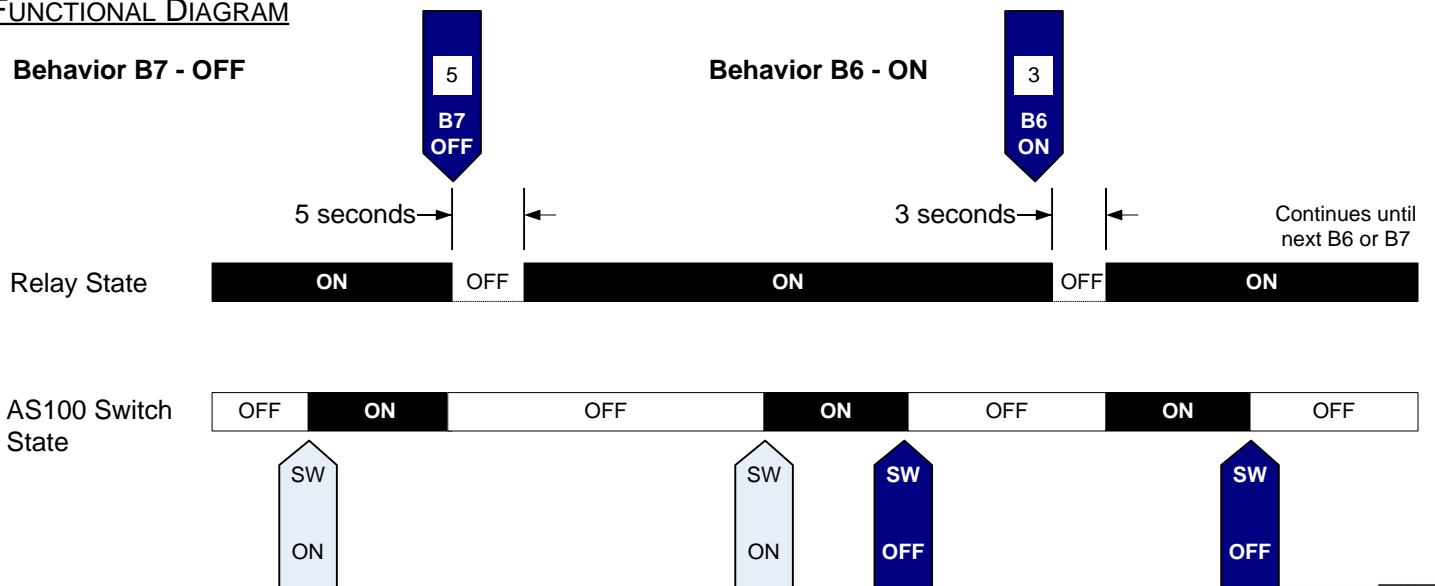



WIRING DIAGRAM

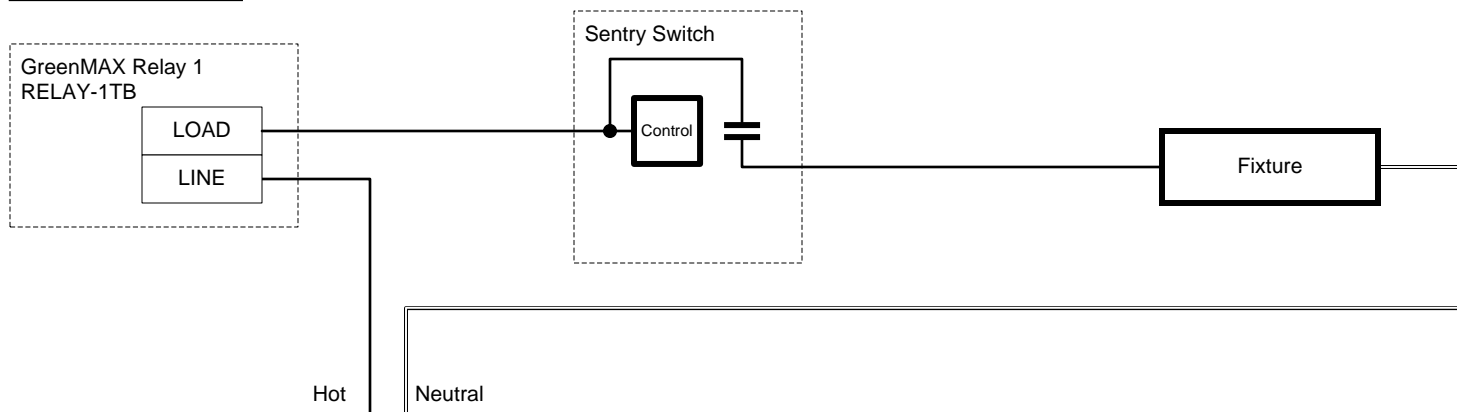

CONFIGURATION DETAILS

<b>Relay Details</b>		<b>Description</b>	
Number: 1		Relay 01	
Channel: 1			
Type: 1TB			
<b>Ignore</b>		<input checked="" type="checkbox"/> Pulsed Relay	
<input type="checkbox"/> Blink Warn Enabled		<input type="checkbox"/> Normally Open	
BW Time: 0.5 Sec.		<input type="checkbox"/> On: [ ] Sec	
BW Delay: 1 Min.		<input checked="" type="checkbox"/> Off: 5.0 Sec	
BW Ovr: 4 Min.		Emergency	
		Ignore	
Prev	Next	Test	OK Cancel

**PULSED RELAY**

When this box is checked the relay will:

- Respond to a Behavior B7 OFF with a short OFF pulse. The duration of the pulse is determined by the value in the OFF field.
- The relay will return to the closed position and maintain that position until the next scheduled Behavior B7.

**OFF PULSE LENGTH**

SENTRY SWITCH NORMAL OPERATING MODE

3 Sec Turn OFF

**NOTE:**

These settings will not be applied until the Normal/Override switch is cycled.

FUNCTIONAL DIAGRAM

**Behavior B7 - OFF**

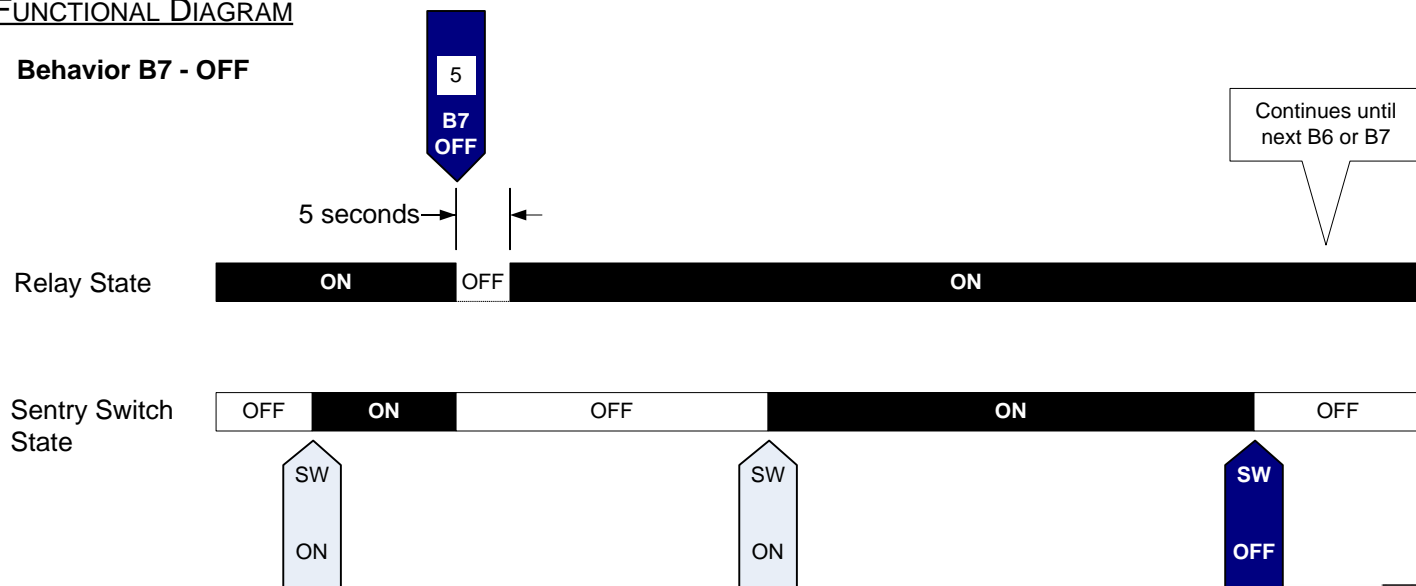

Continues until next B6 or B7



WIRING DIAGRAM

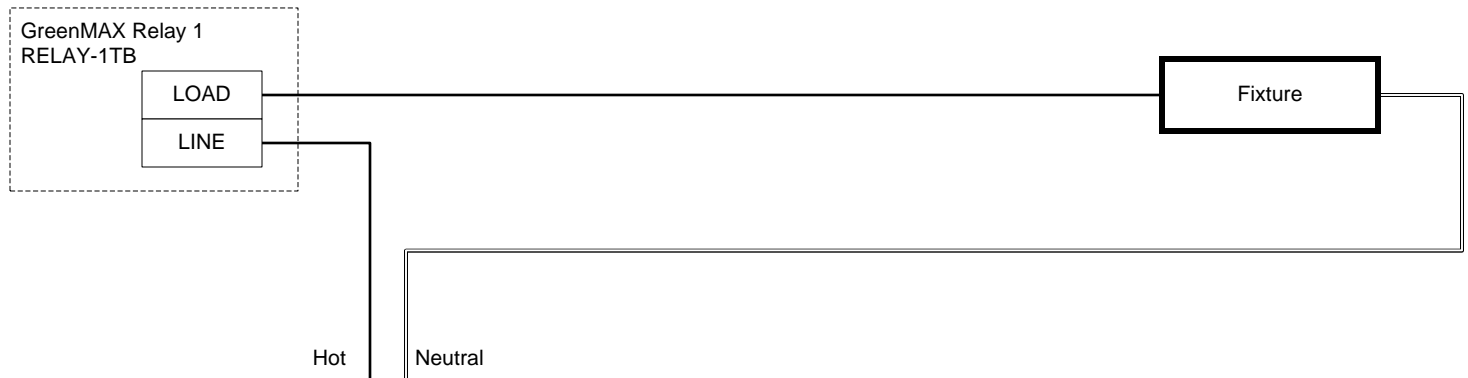

CONFIGURATION DETAILS

**Agenda Behavior Transition Detail**

Transition to behavior: Behavior 5

Absolute Time 5:00 PM

Offset N/A N/A N/A

Swt Delay N/A BW Time 1

Occ Delay N/A BW Delay 5 min

Ignore PC Delay N/A BW Ovr 25 min

OK Cancel

**NOTE:**  
 These settings associated with a Behavior Transition will supersede any of the similar settings found in the System Defaults or Relay Detail Screens.

- BEHAVIOR TRANSITION TIME**

The exact time that the Blink Warn sequence will start, the Blink will signify the start.

  - Can also be scheduled relative to Sunset or Sunrise offset times.
- BW TIME**

Set for the length of the OFF Blink.

  - This is intended to warn any occupants of the affected space that the lights will be turning OFF.
  - The relay will turn ON once the Blink duration has expired.
- BW DELAY**

Set for the length of time the relay should be ON after the OFF Blink.

  - This is intended to allow occupants of the affected space to interrupt the Blink Warn sequence and keep the lights on for the Over-ride duration.
  - A button press will interrupt the sequence.
  - If no button press is detected during this period, the relay will turn OFF.
- BW OVER-RIDE**

Set for the length of time the relay should be ON after a button press.

  - The relay will remain ON for this duration. A button press will turn the relay OFF and stop all timing functions.
  - At the end of this period, another complete Blink Warn sequence will start.



**Scenario 1 - Behavior B5 – Blink Warn**

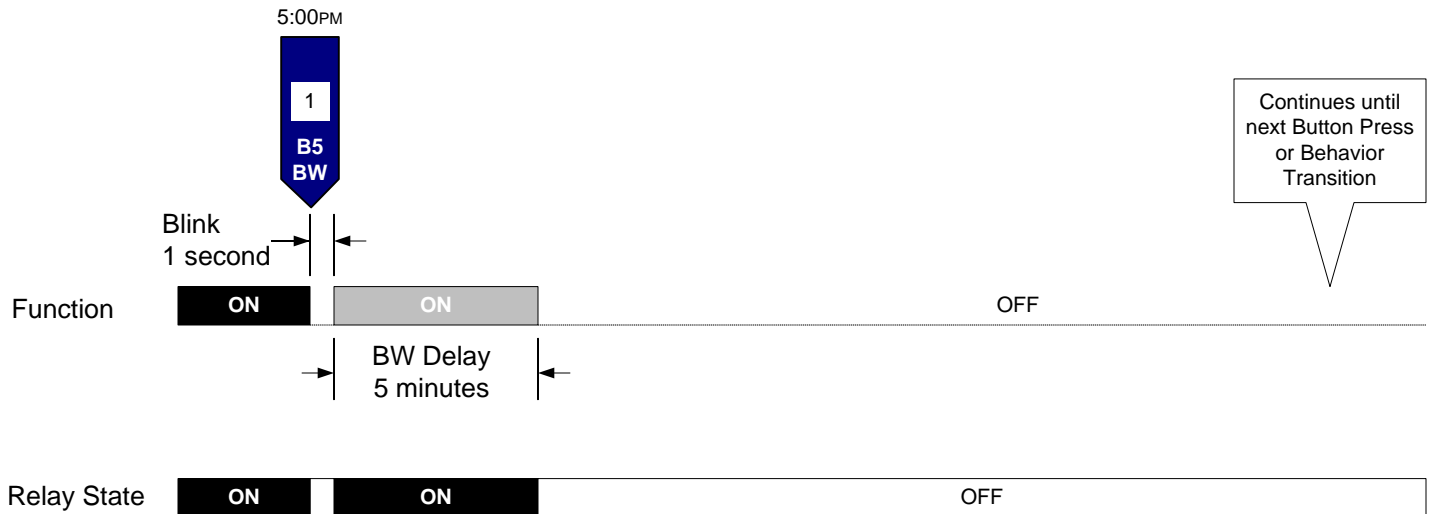

**Scenario 2 - Behavior B5 – Blink Warn**

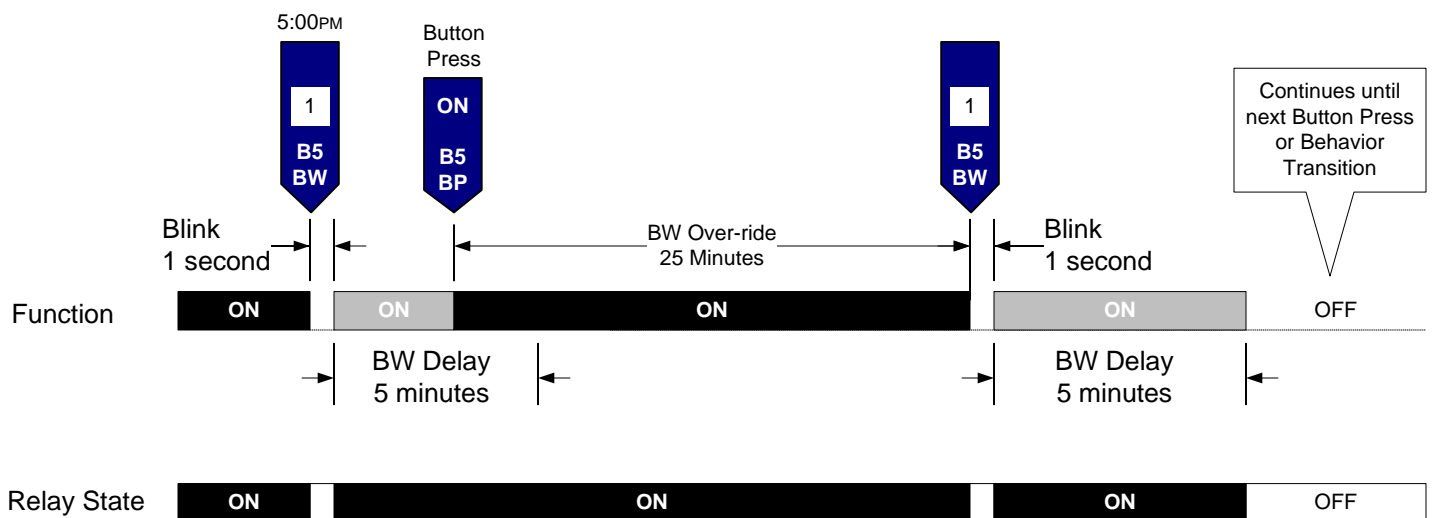

**Scenario 3 - Behavior B5 – Blink Warn**

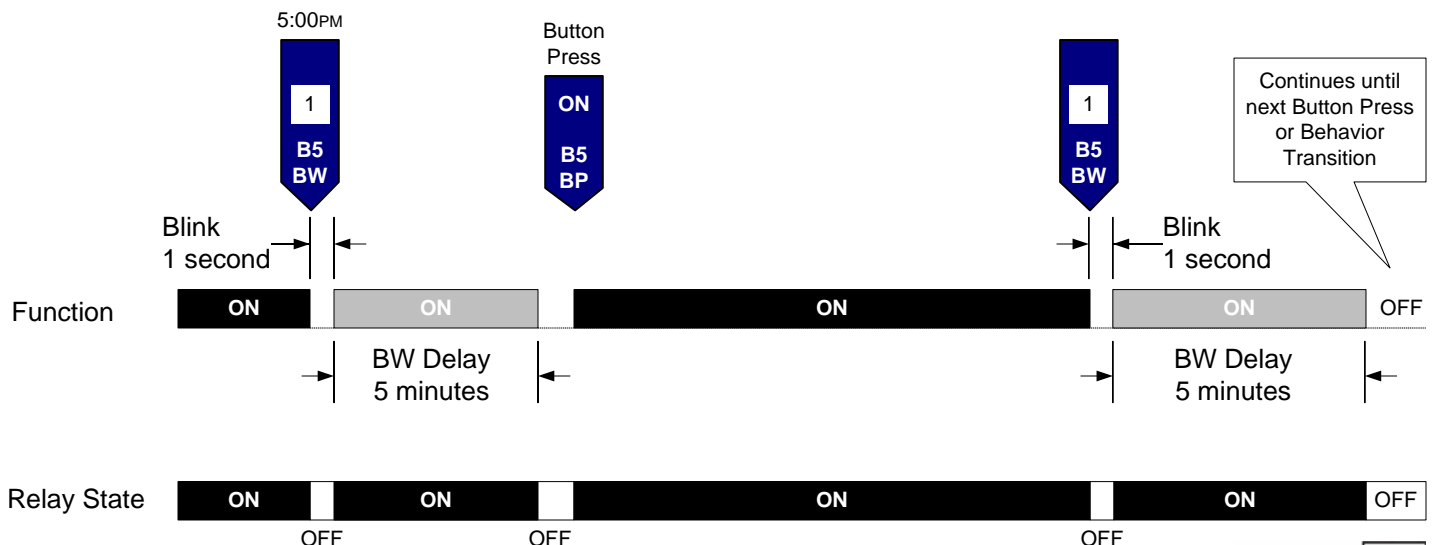





CONFIGURATION DETAILS

**Digital Switch Button Details**

Type: Momentary DS Button      Button #: 1

Id: \_\_\_\_\_ Initial Level: 50%  
 Delay: N/A      Ignore: \_\_\_\_\_  
 Override: N/A

Description: \_\_\_\_\_

Relay / Group
Relay 1

OK    Cancel

**DELAY**

To initialize the timed switch functionality, adjust the DELAY to a value other than N/A. Once this value is changed, the switch will always be in timed switch mode and will require a value.

- This is value represents the default value for the switch.
- A value of INF (infinite) will prevent the switch delay timer from timing out. The switch will function as a normal switch.
- His value will be over-written by the Delay value of the Behavior Transition

**Agenda Behavior Transition Detail**

Transition to behavior: Behavior 4

Absolute Time      5:00 PM  
 Offset      N/A      N/A      N/A

Swt Delay: 30 min      BW Time: N/A  
 Occ Delay: N/A      BW Delay: N/A  
 Ignore: \_\_\_\_\_  
 PC Delay: N/A      BW Ovr: N/A

OK    Cancel

**BEHAVIOR TRANSITION TIME**

The exact time that the Blink Warn sequence will start, the Blink will signify the start.

- Can also be scheduled relative to Sunset or Sunrise offset times.

**SWT DELAY (SWITCH DELAY)**

Set for the length of time the relay should be ON after a button press.

- The relay will remain ON for this duration. A button press will turn the relay OFF and stop all timing functions.
- At the end of this period the relay will turn OFF

**NOTE:**  
 Both of these screens must be configured to provide the Timed Switch functionality. The Timed Switch will work with any Behavior that contains a switch.

FUNCTIONAL DIAGRAM

**Behavior B4 – with Off Delay – Timed Switch**

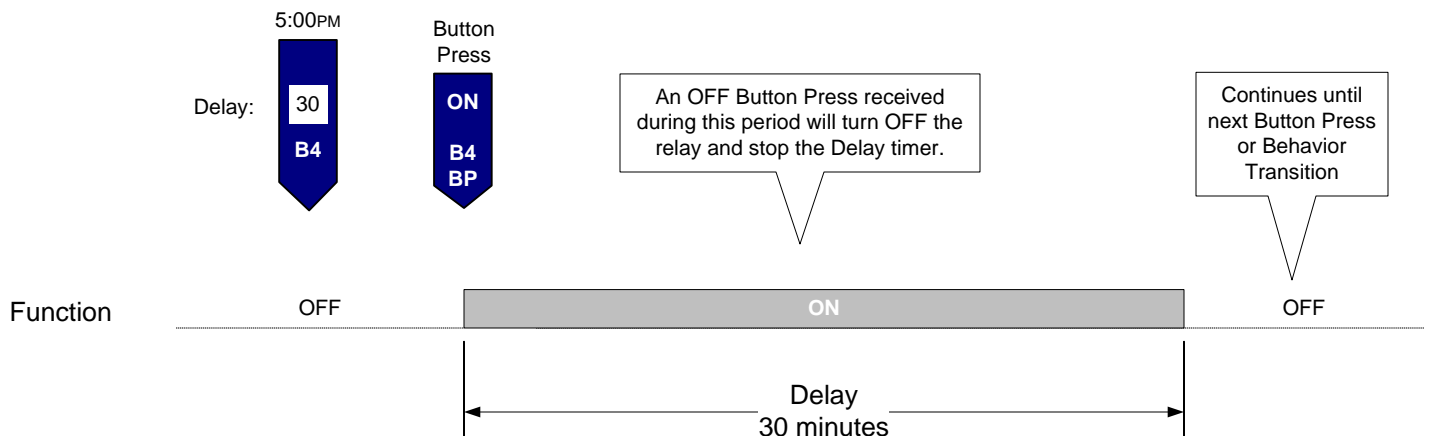



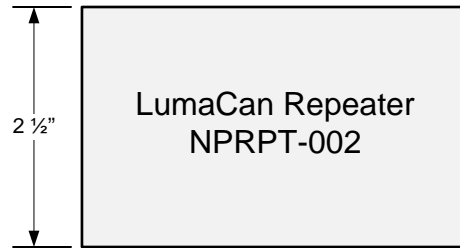

Top View

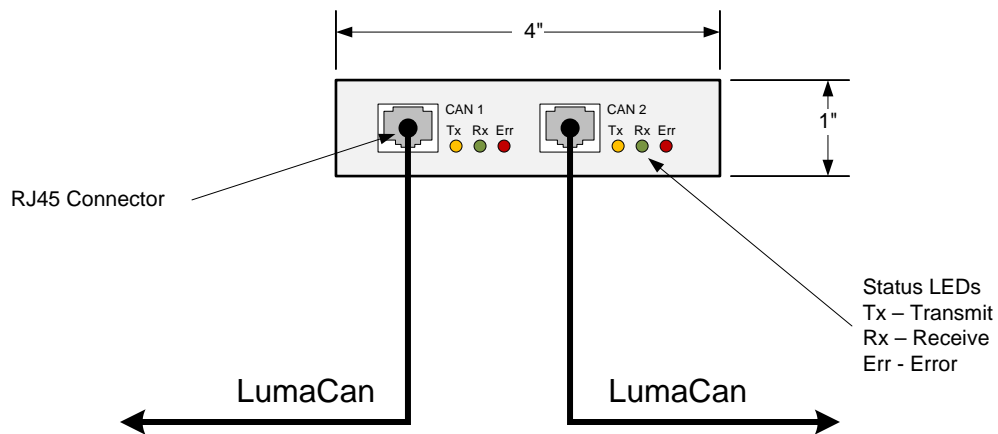

Front View  
with  
Connections

**NOTES:**

- Surface top and bottom is smooth.
- Mounted using two sided tape.
- Derives its power from the LumaCan.
- Draws 50mA at +24VDC when connected.
- Can be powered by either CAN 1 or CAN 2.



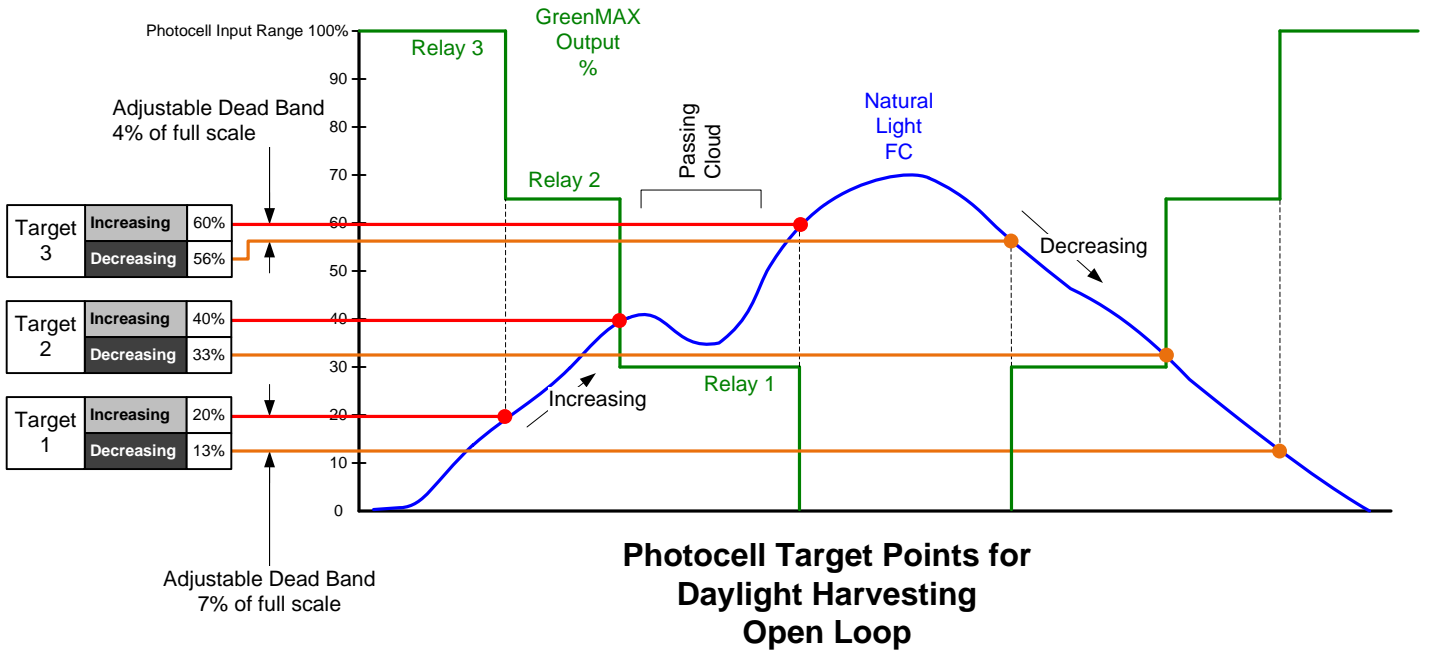

**Photocell Target Points for Daylight Harvesting Open Loop**



# GreenMAX Programming Manual

V2.14

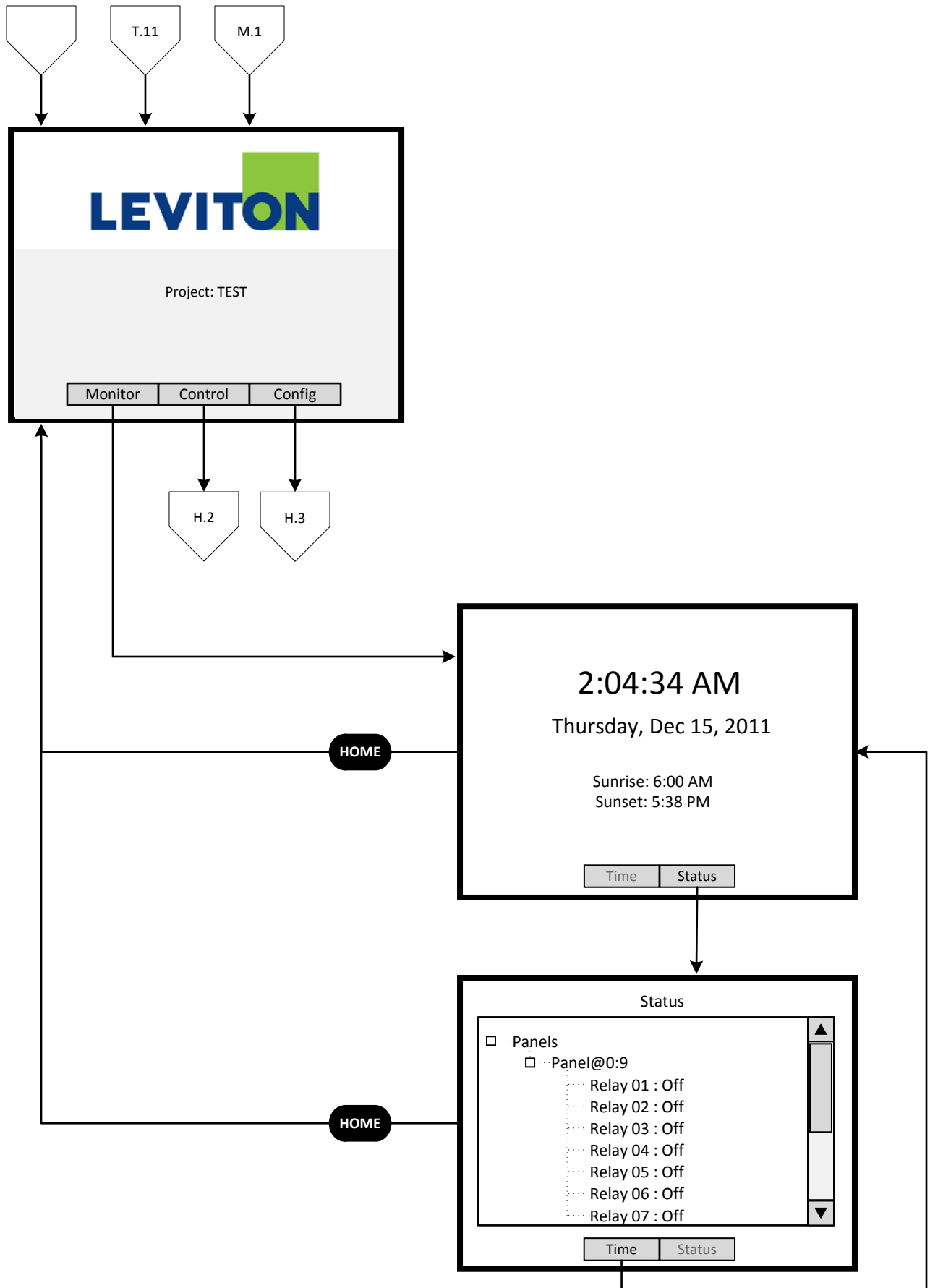



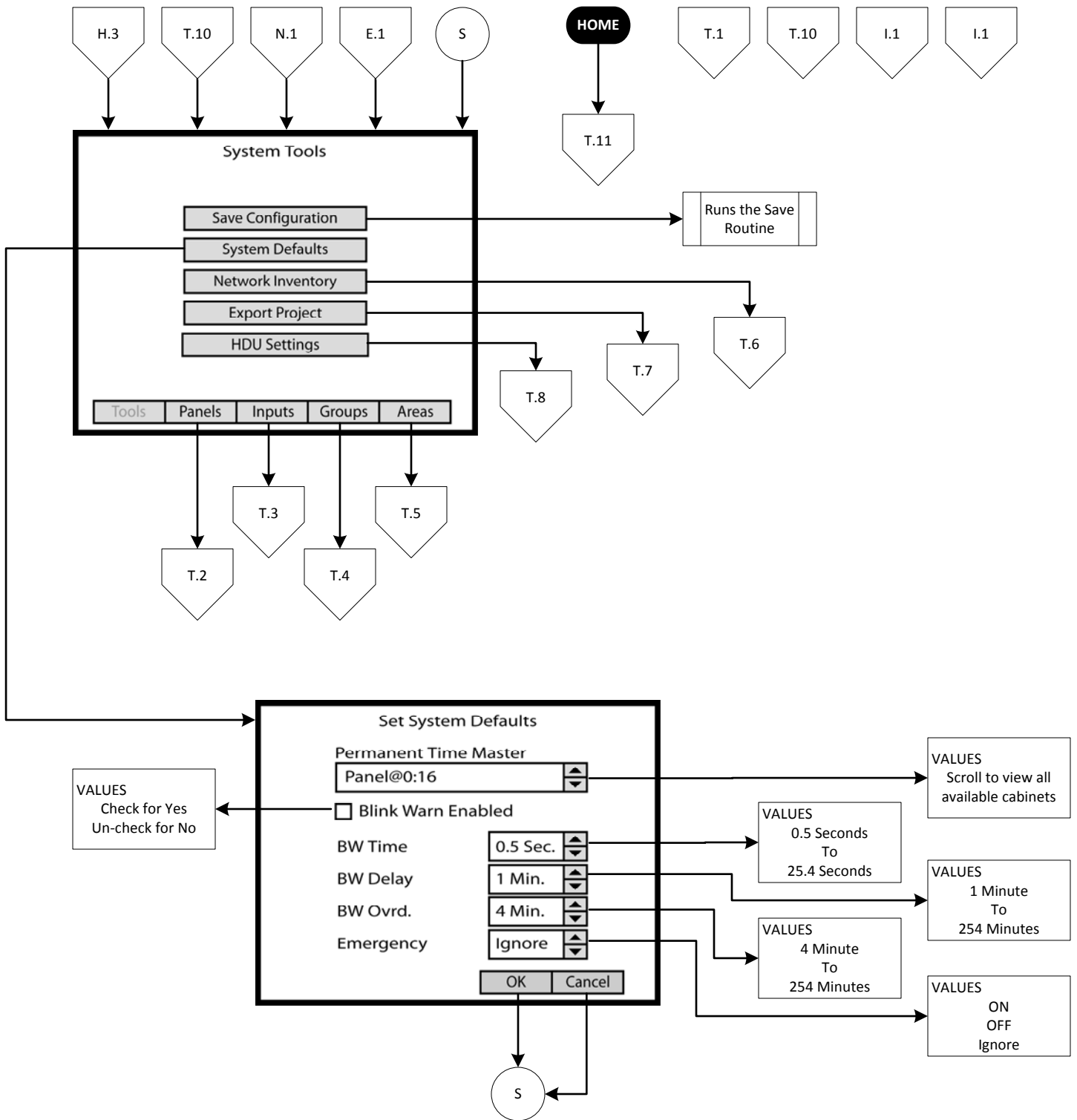

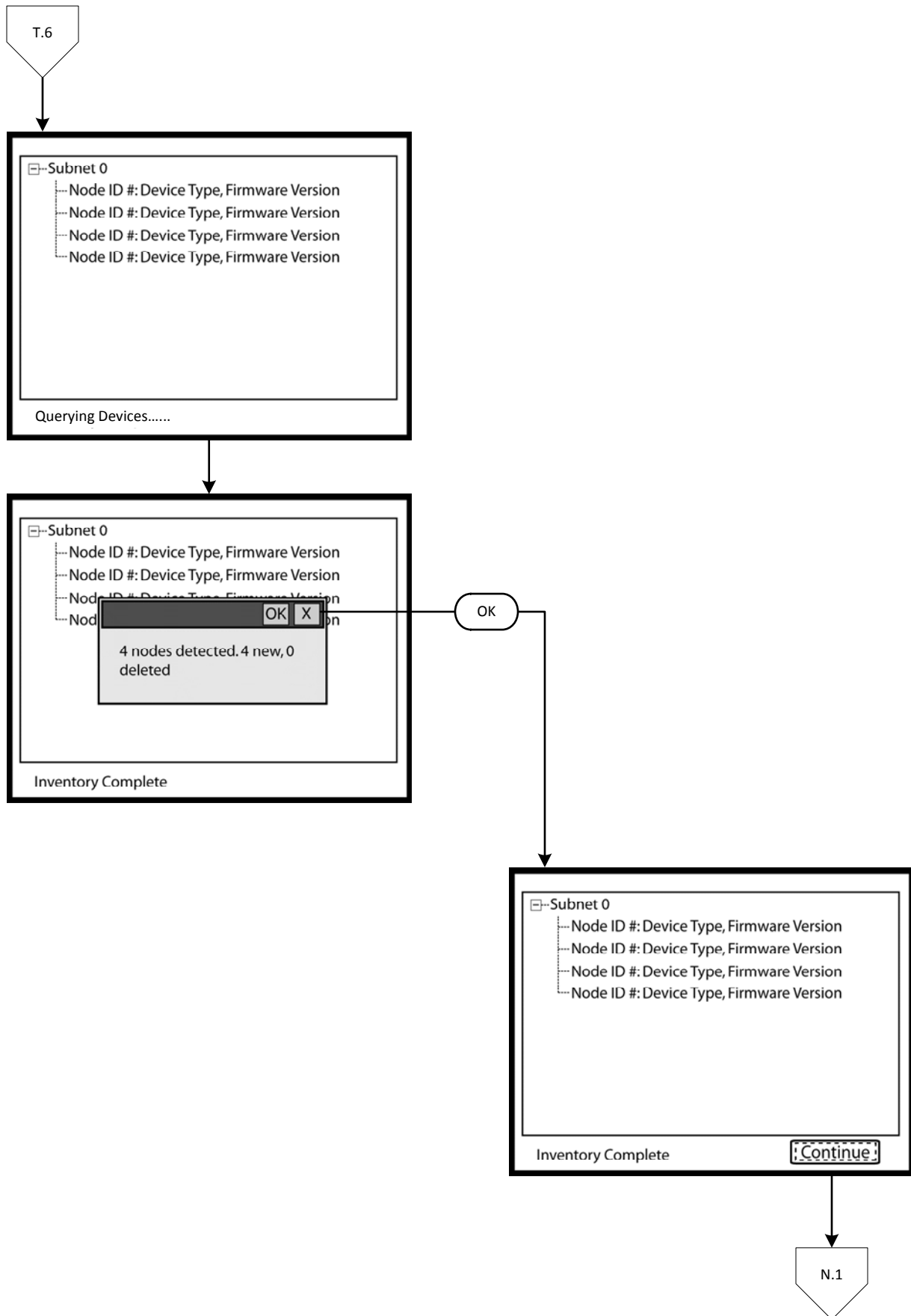

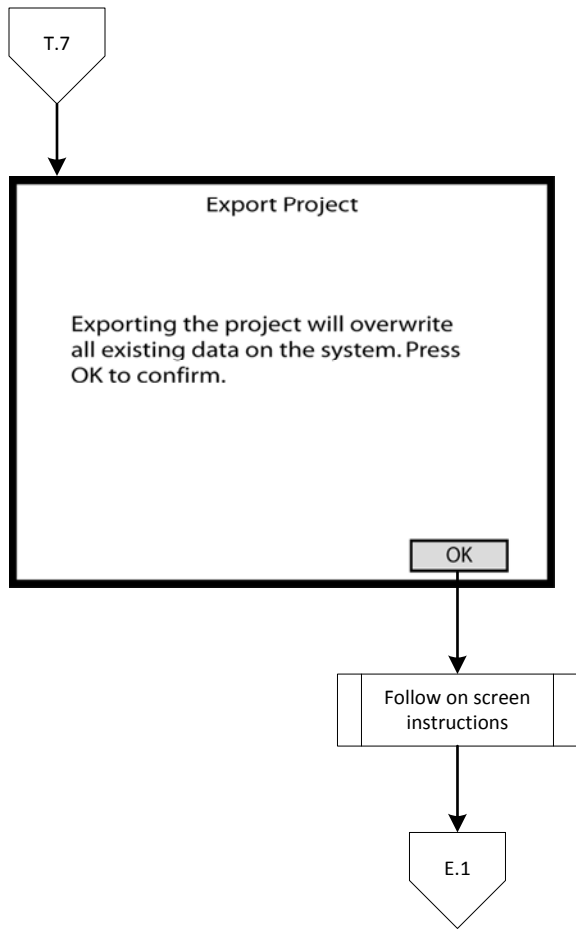

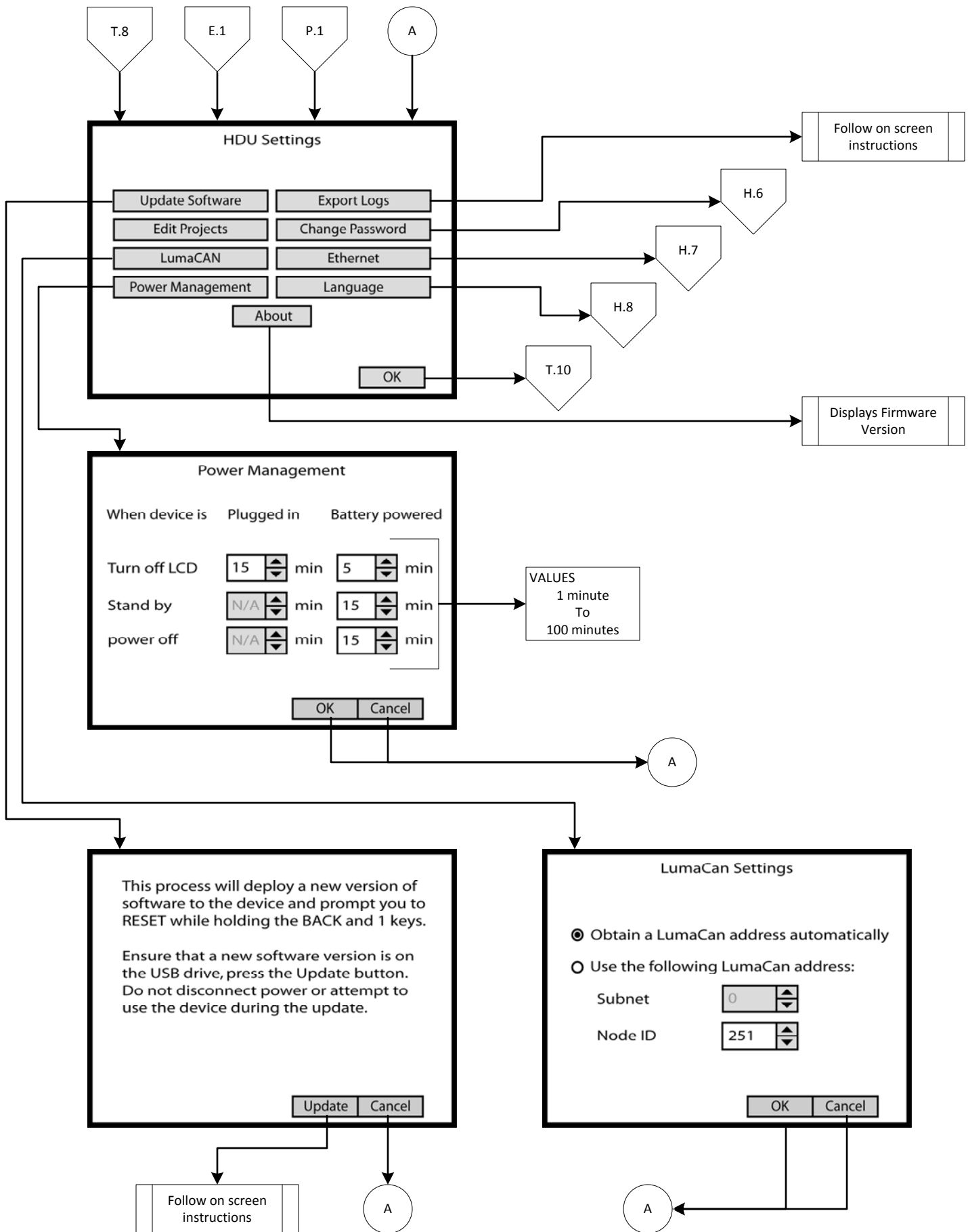

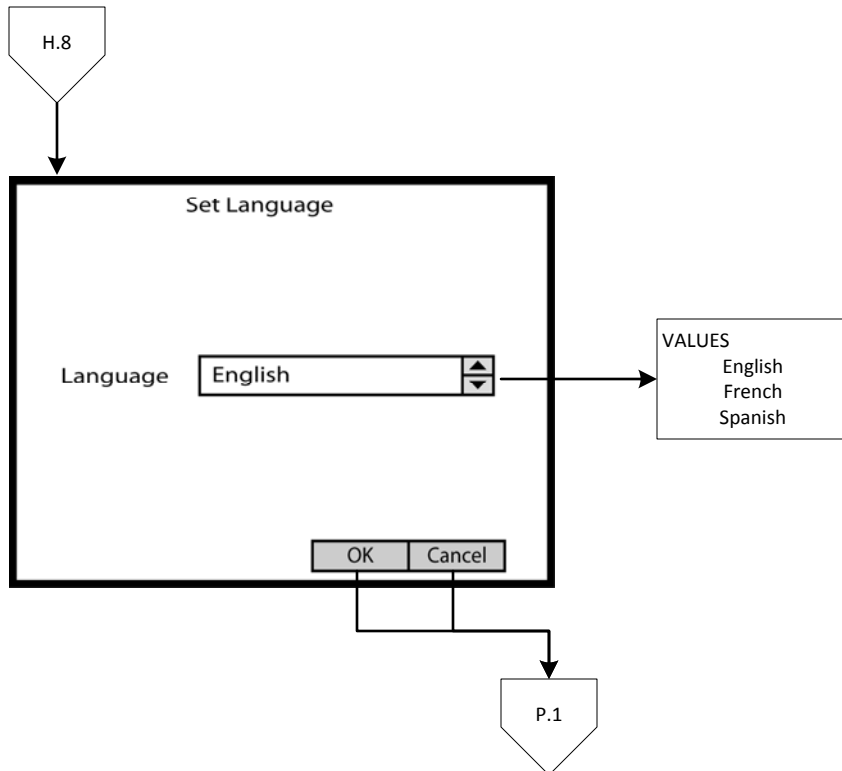
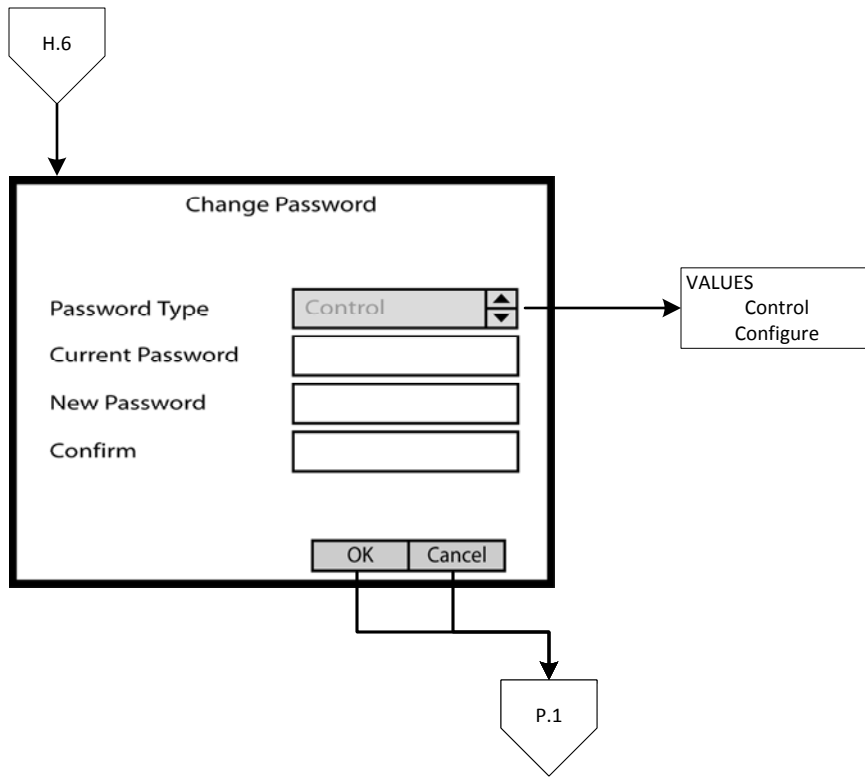

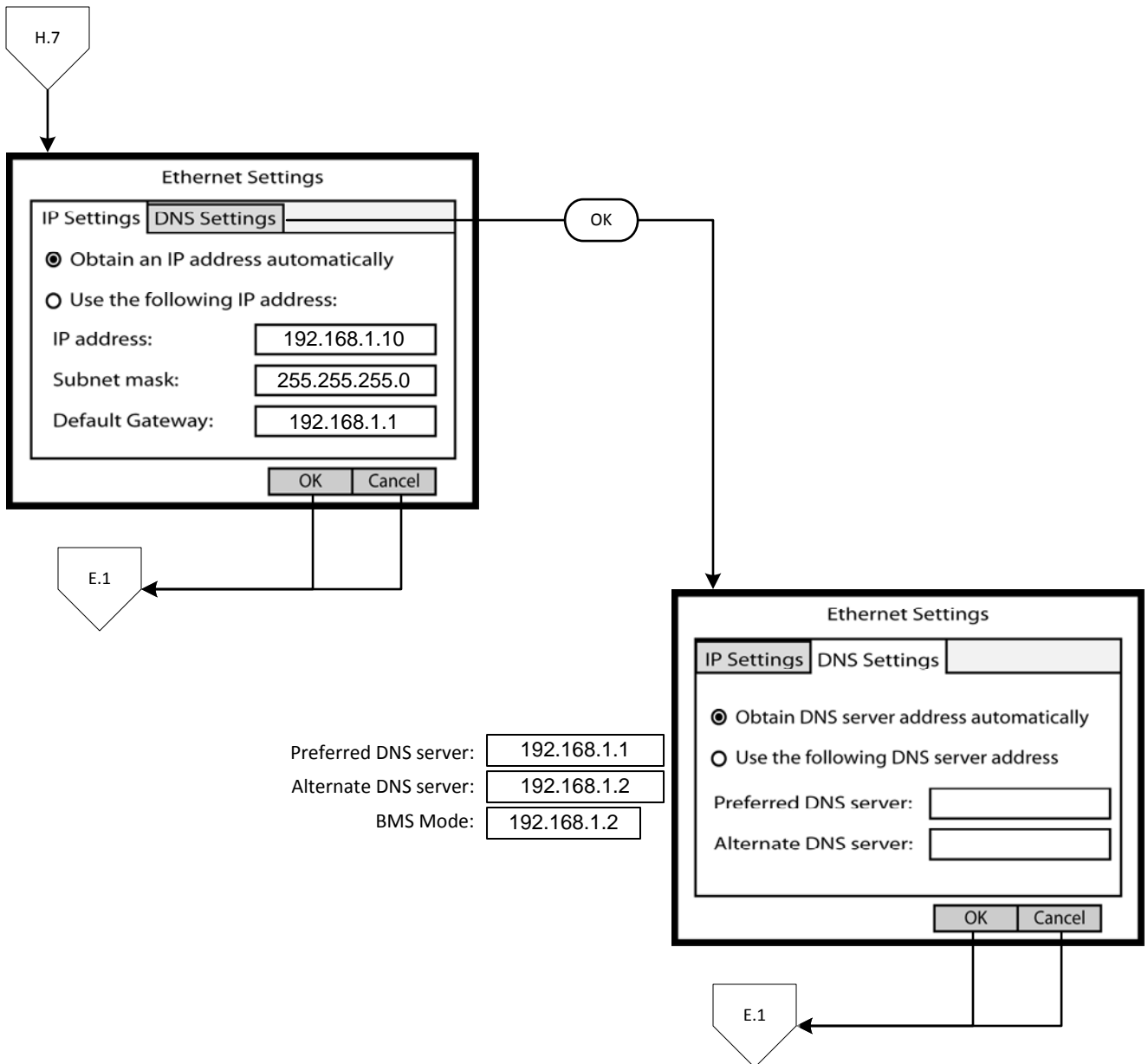

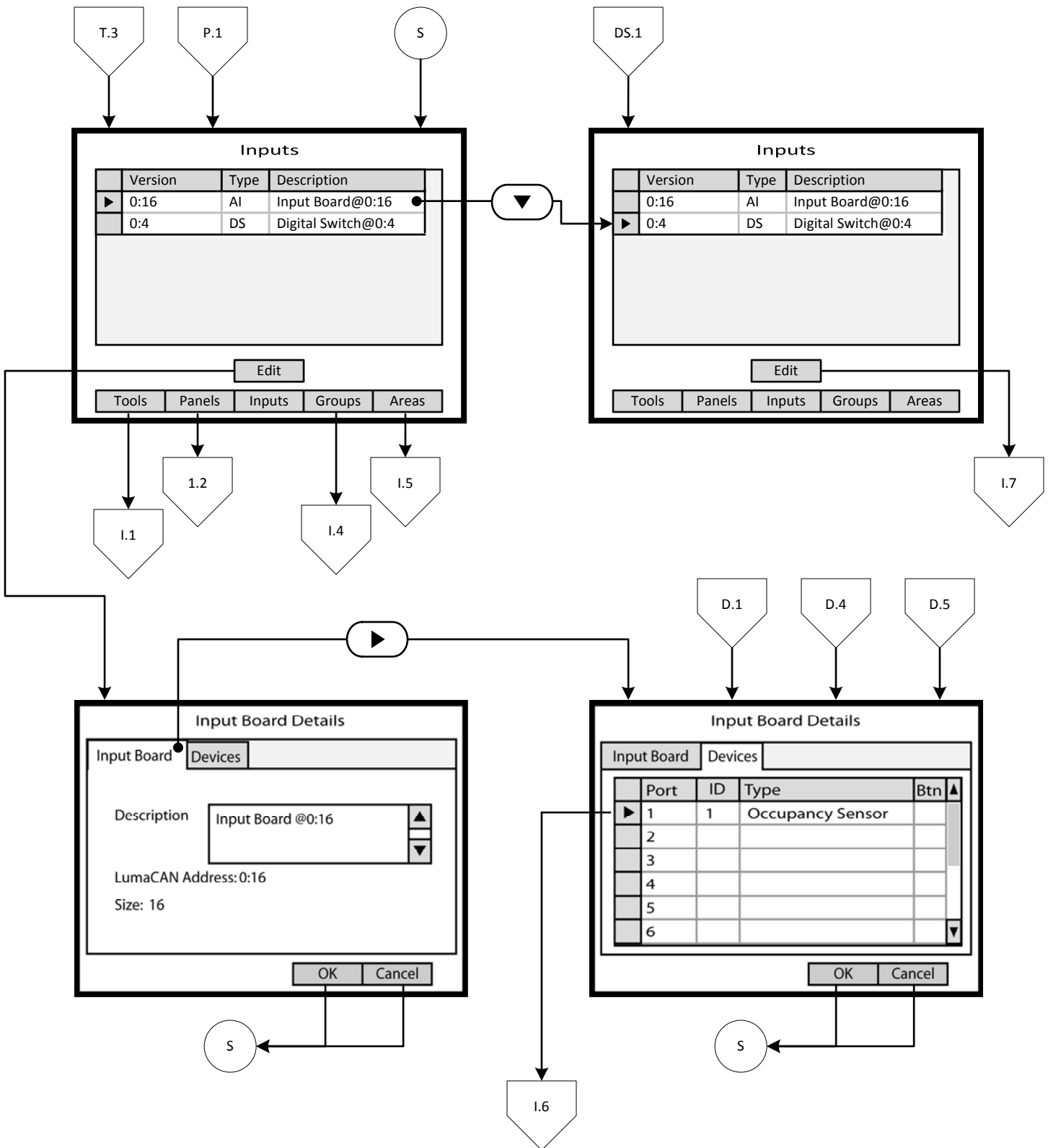

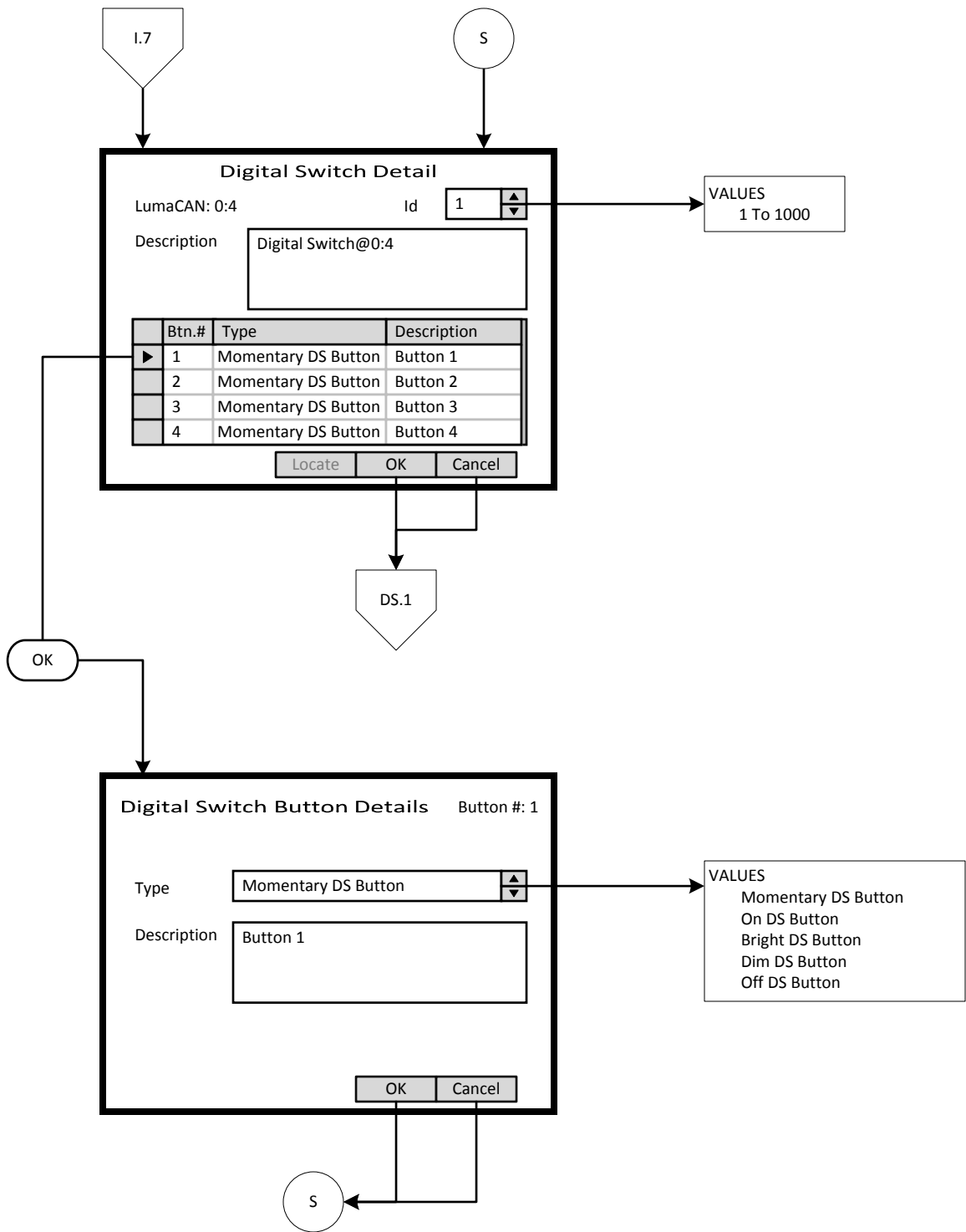



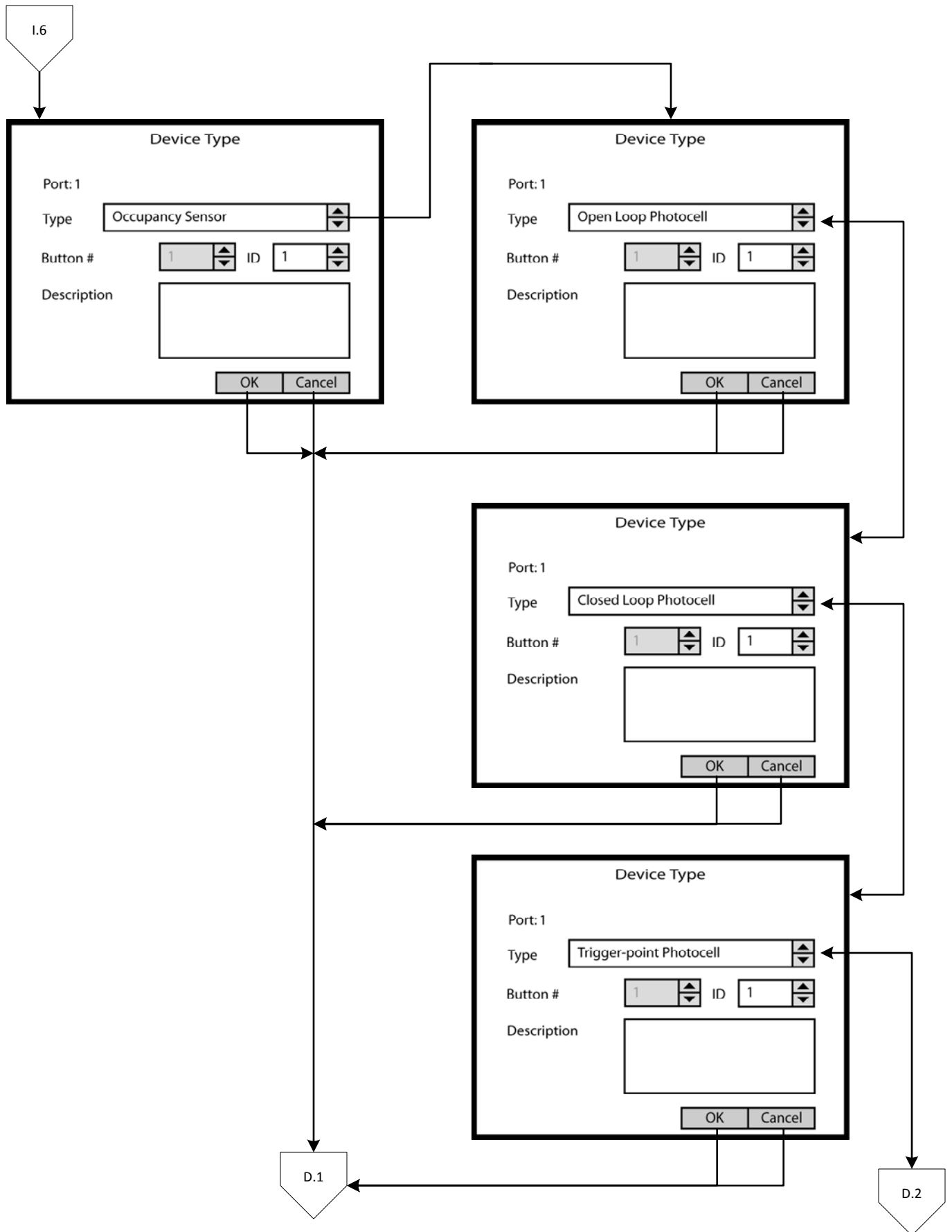

D.2

Device Type

Port: 1

Type

Button #  ID

Description

OK Cancel

Device Type

Port: 1

Type

Button #  ID

Description

OK Cancel

Device Type

Port: 1

Type

Button #  ID

Description

OK Cancel

Device Type

Port: 1

Type

Button #  ID

Description

OK Cancel

Device Type

Port: 1

Type

Button #  ID

Description

OK Cancel

Device Type

Port: 1

Type

Button #  ID

Description

OK Cancel

D.4

D.3

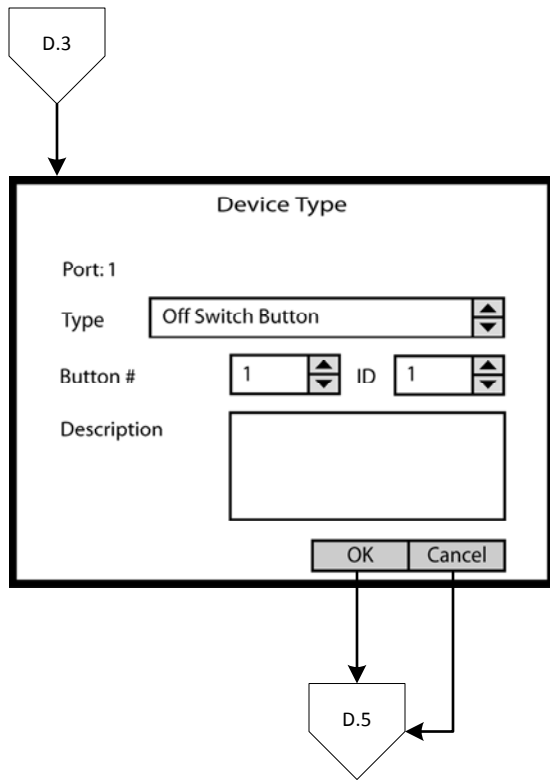

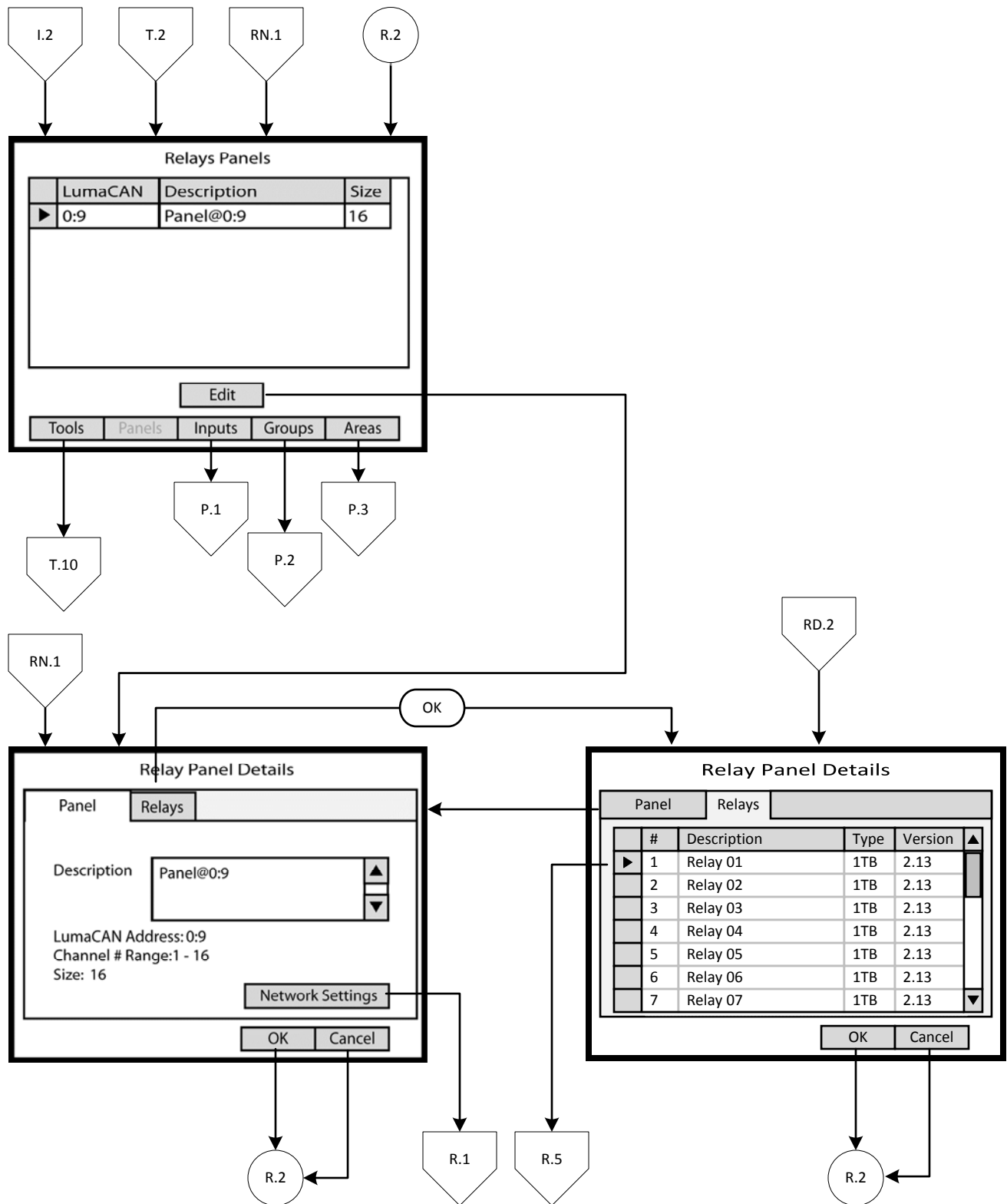

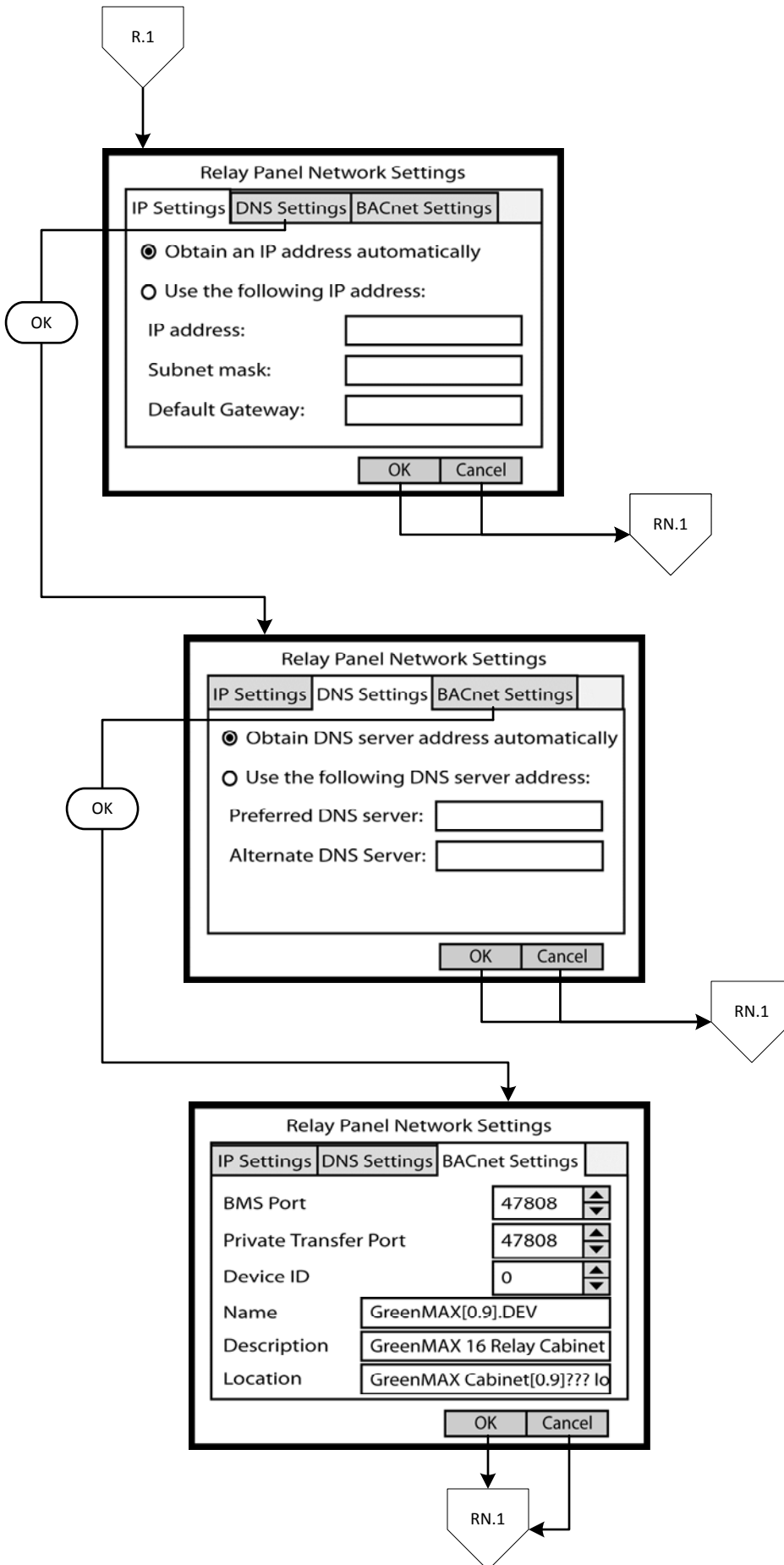

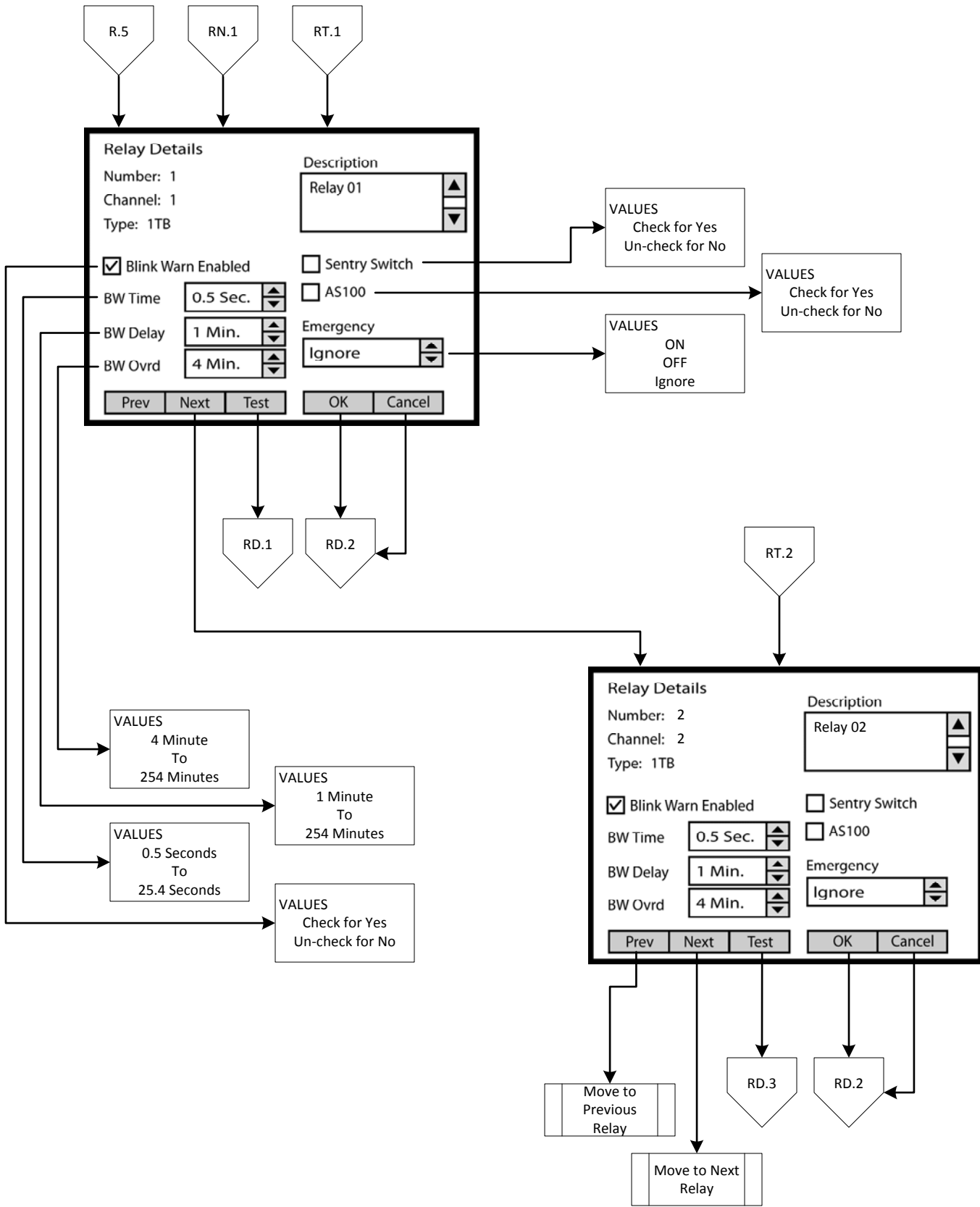

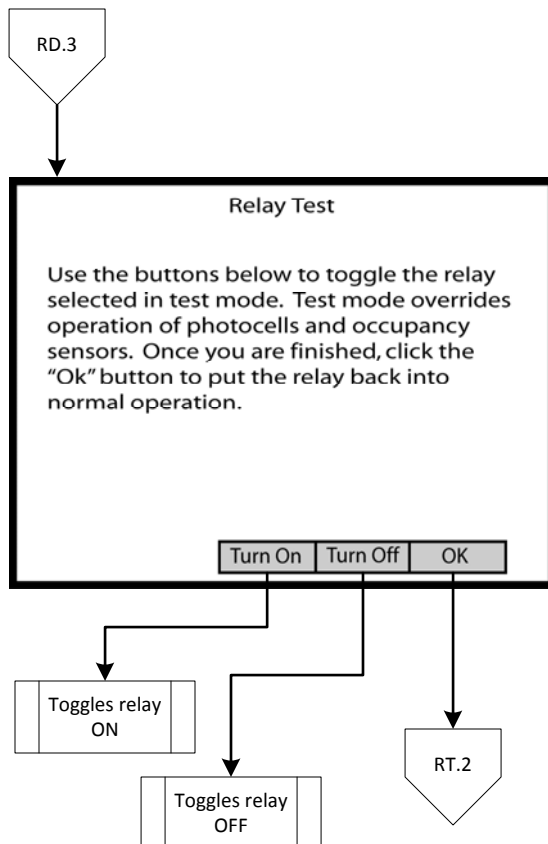
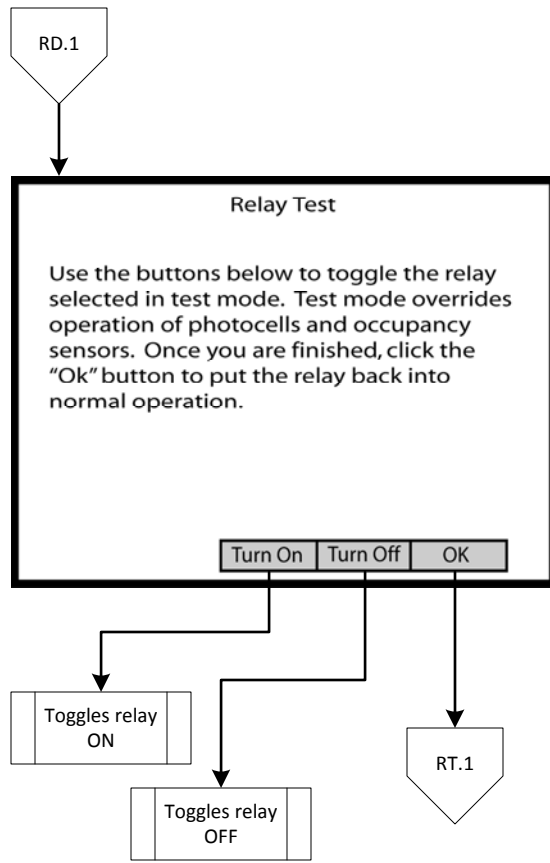

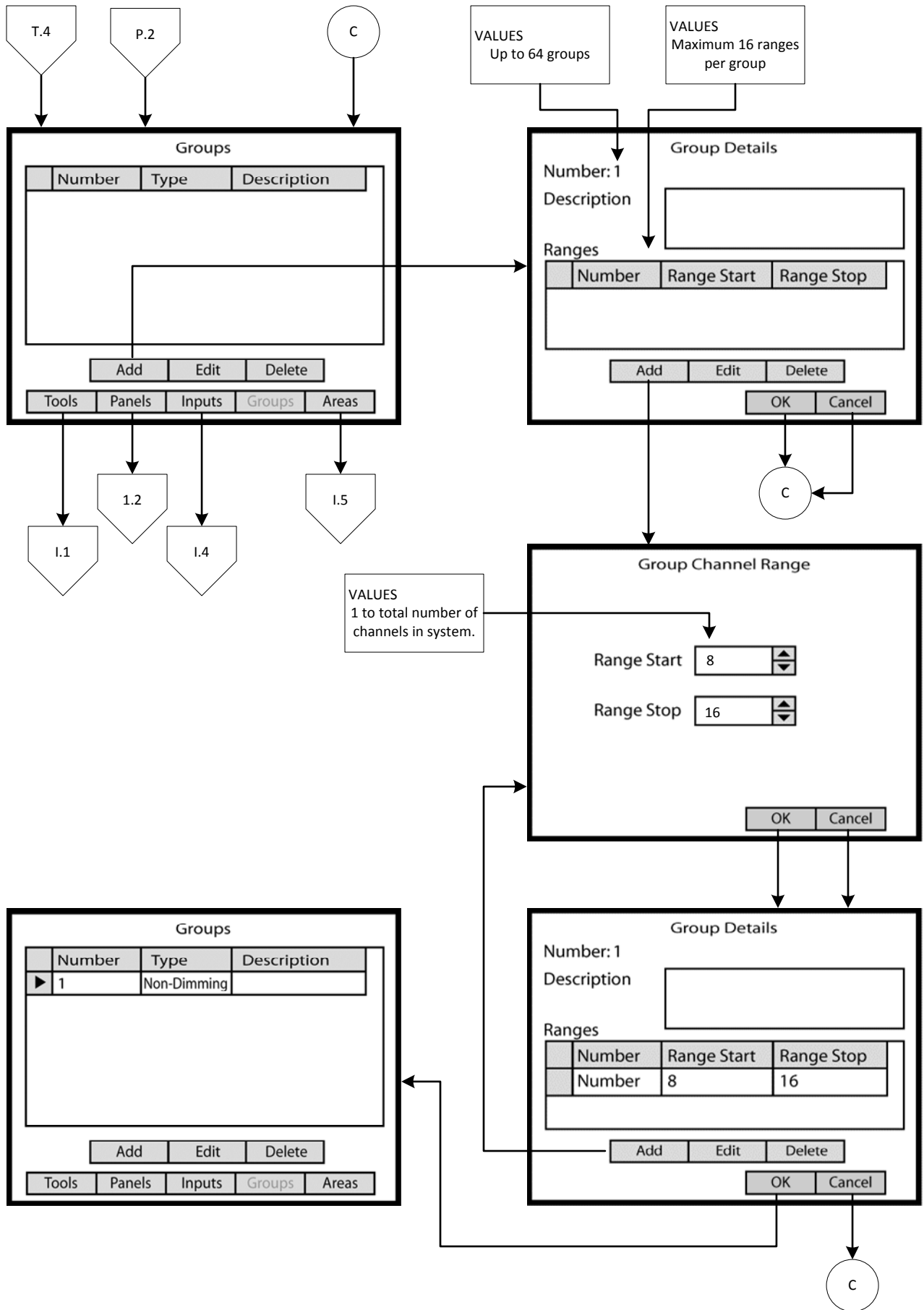



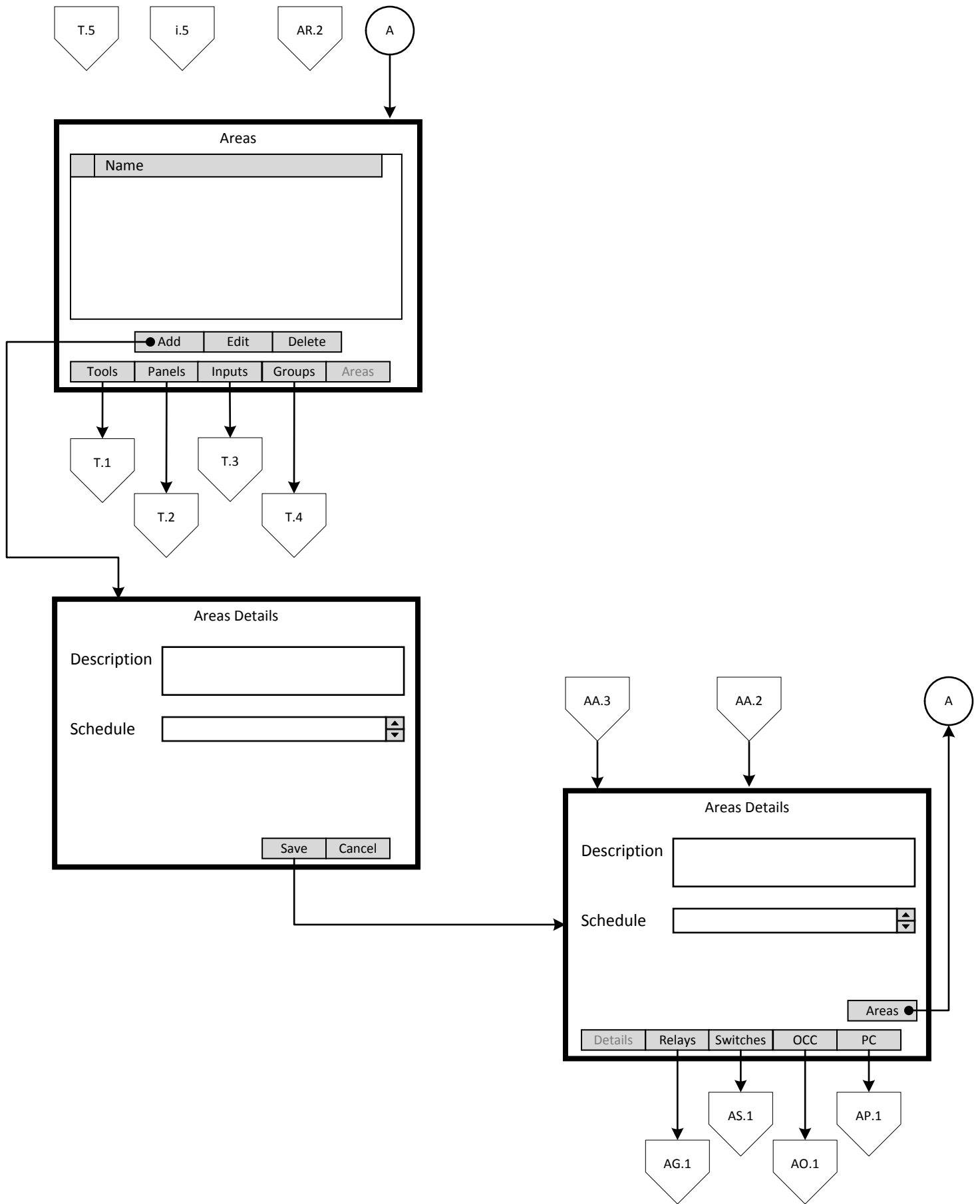

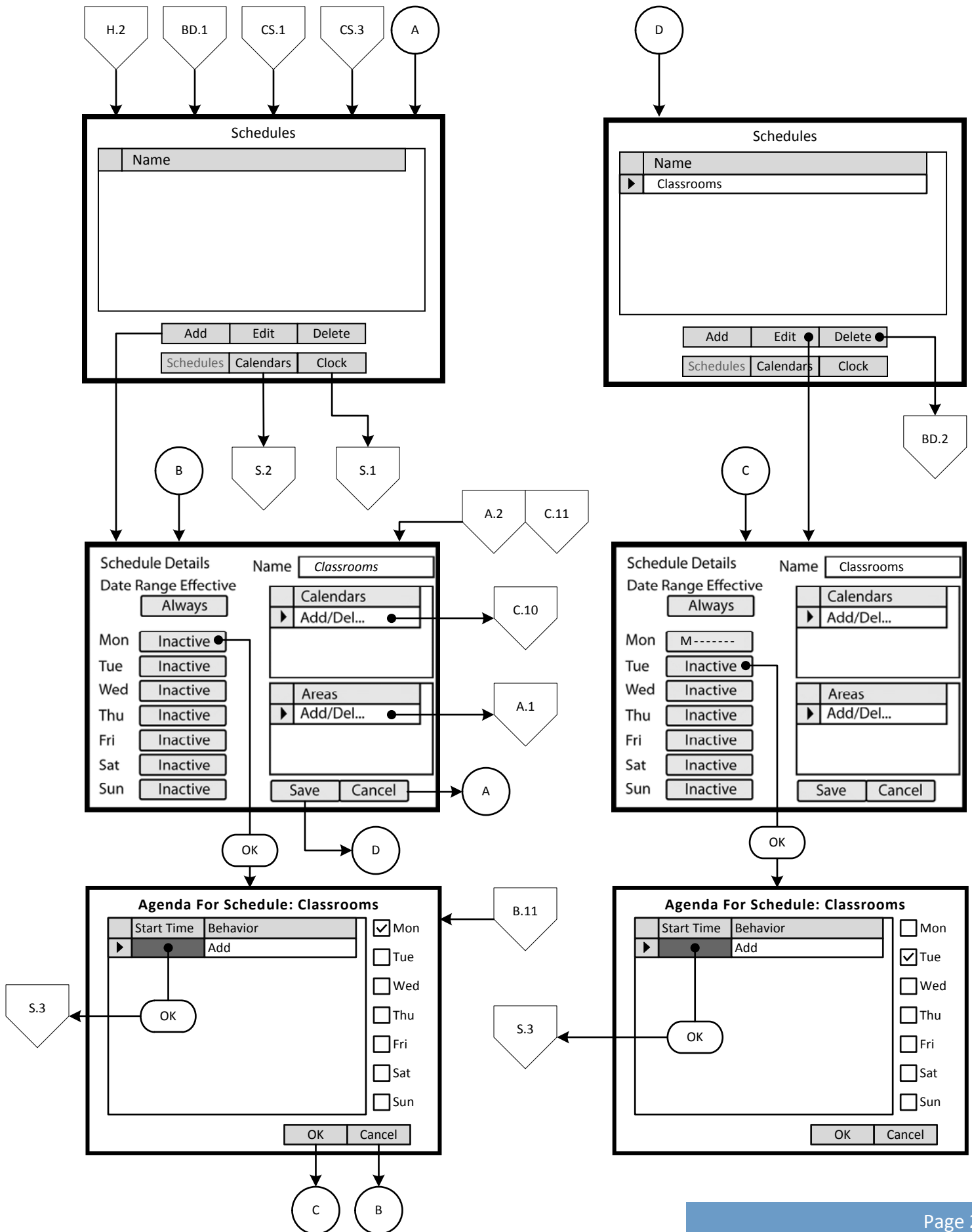

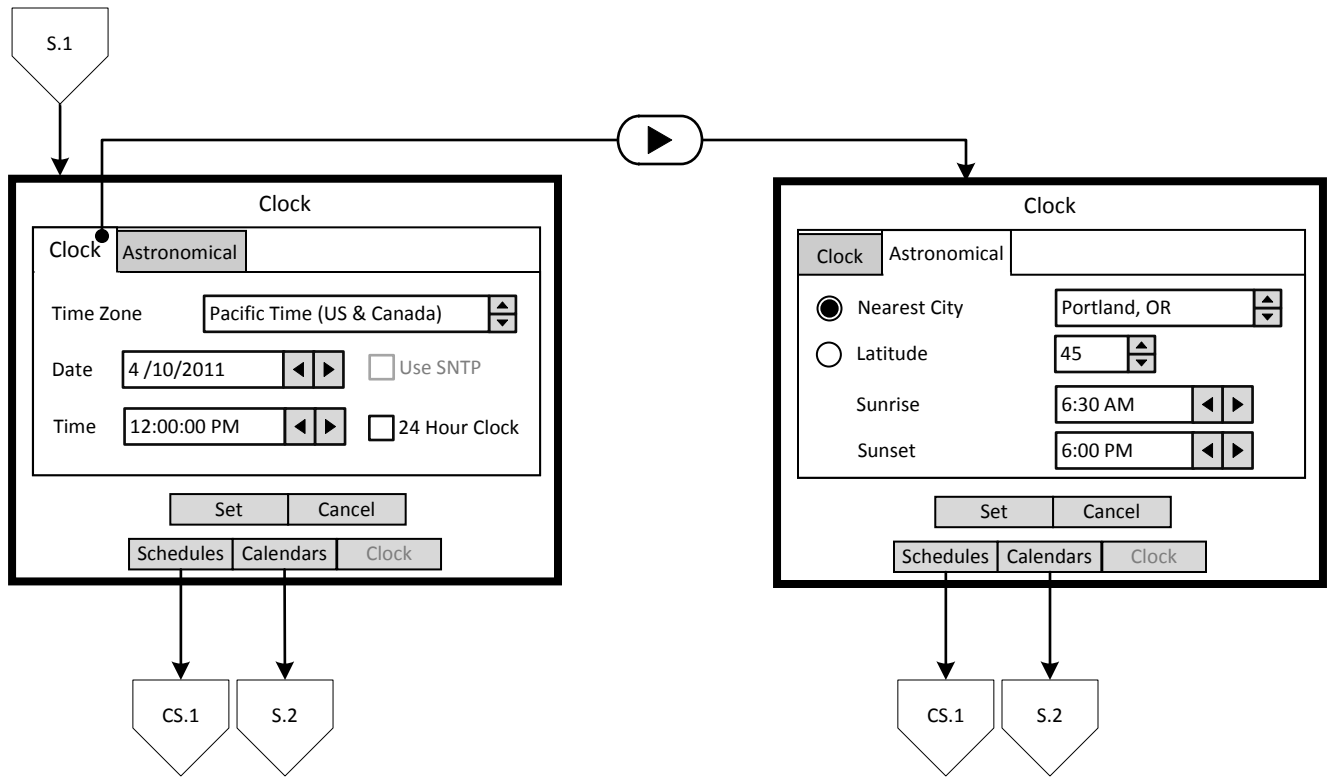

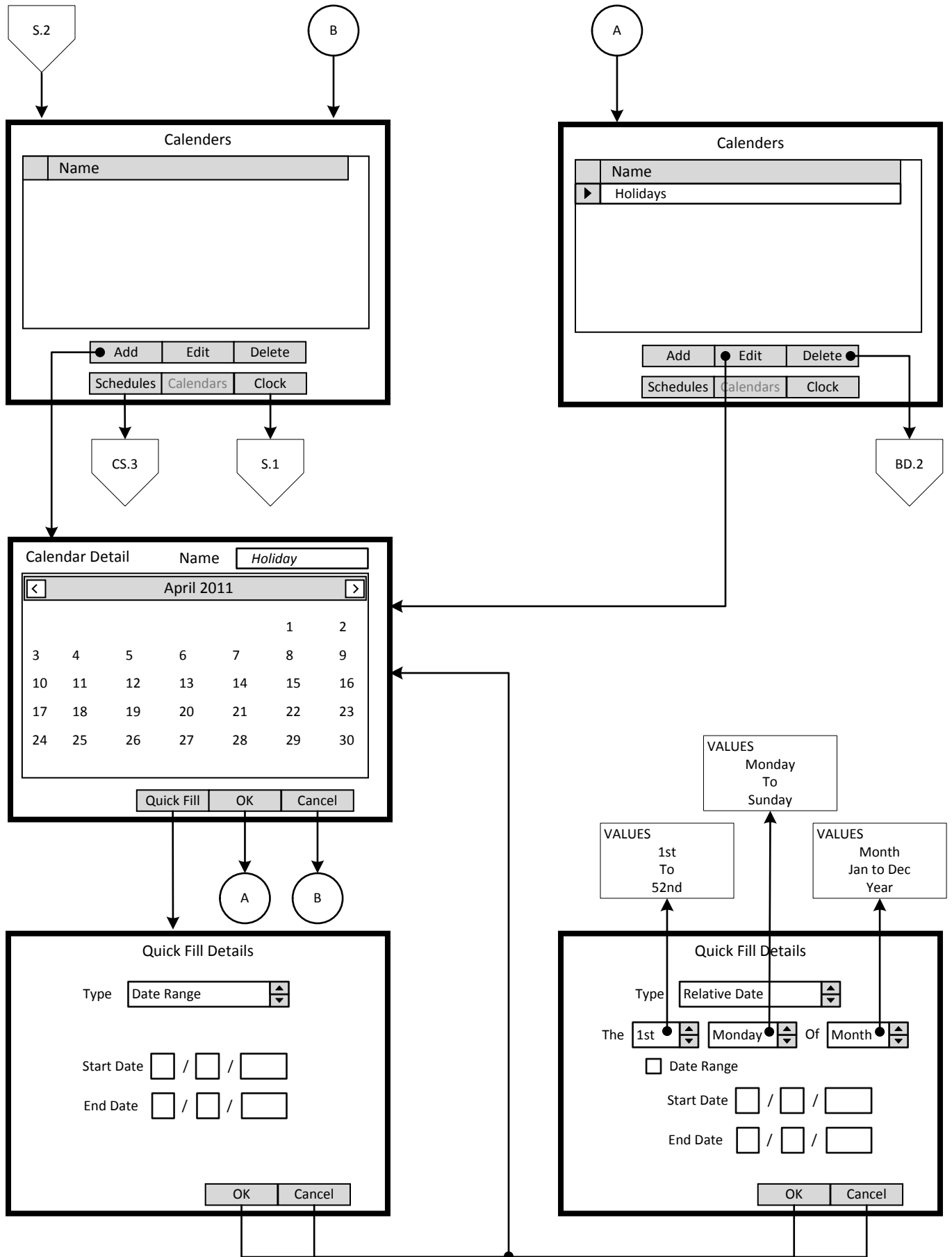

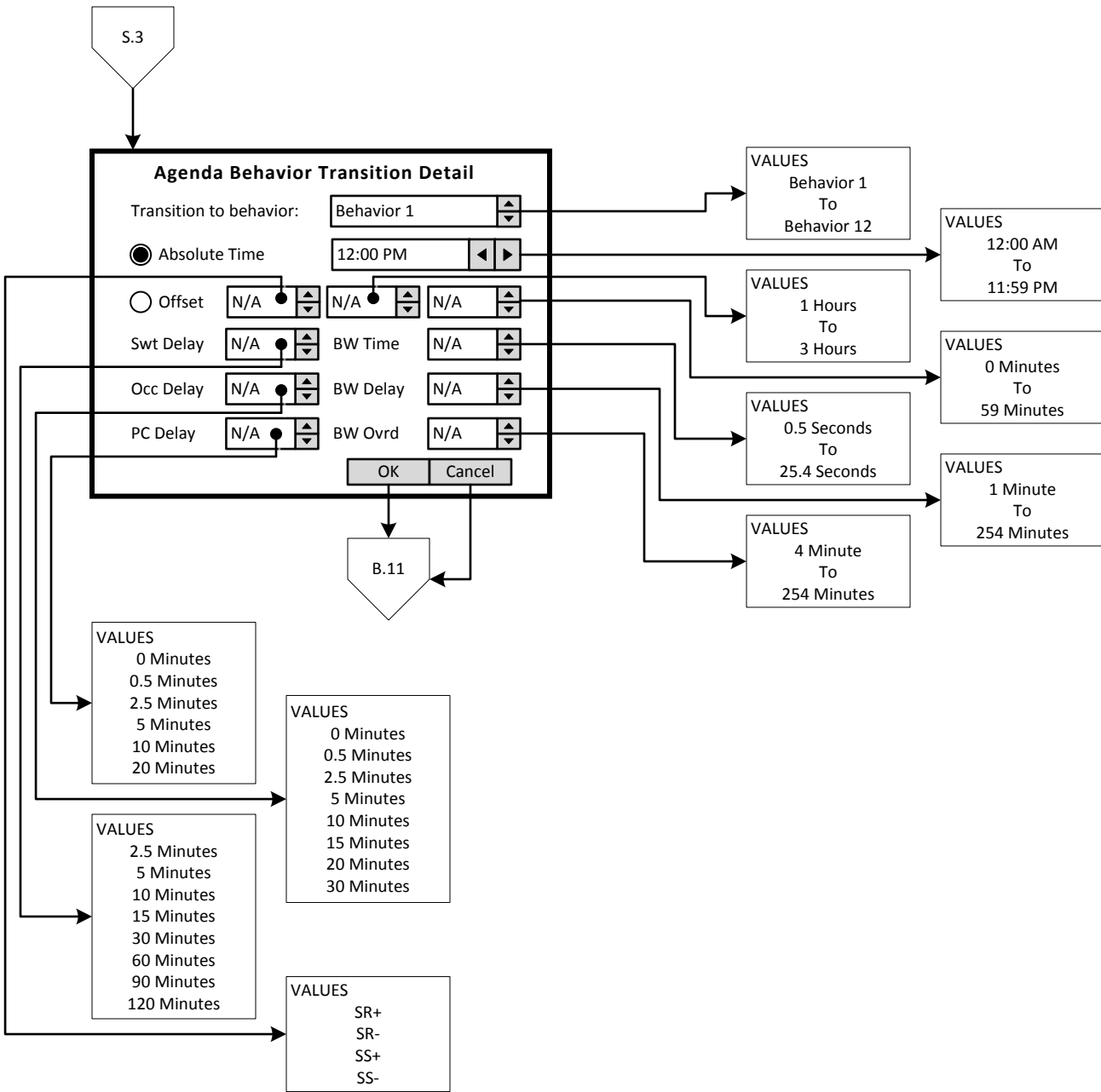

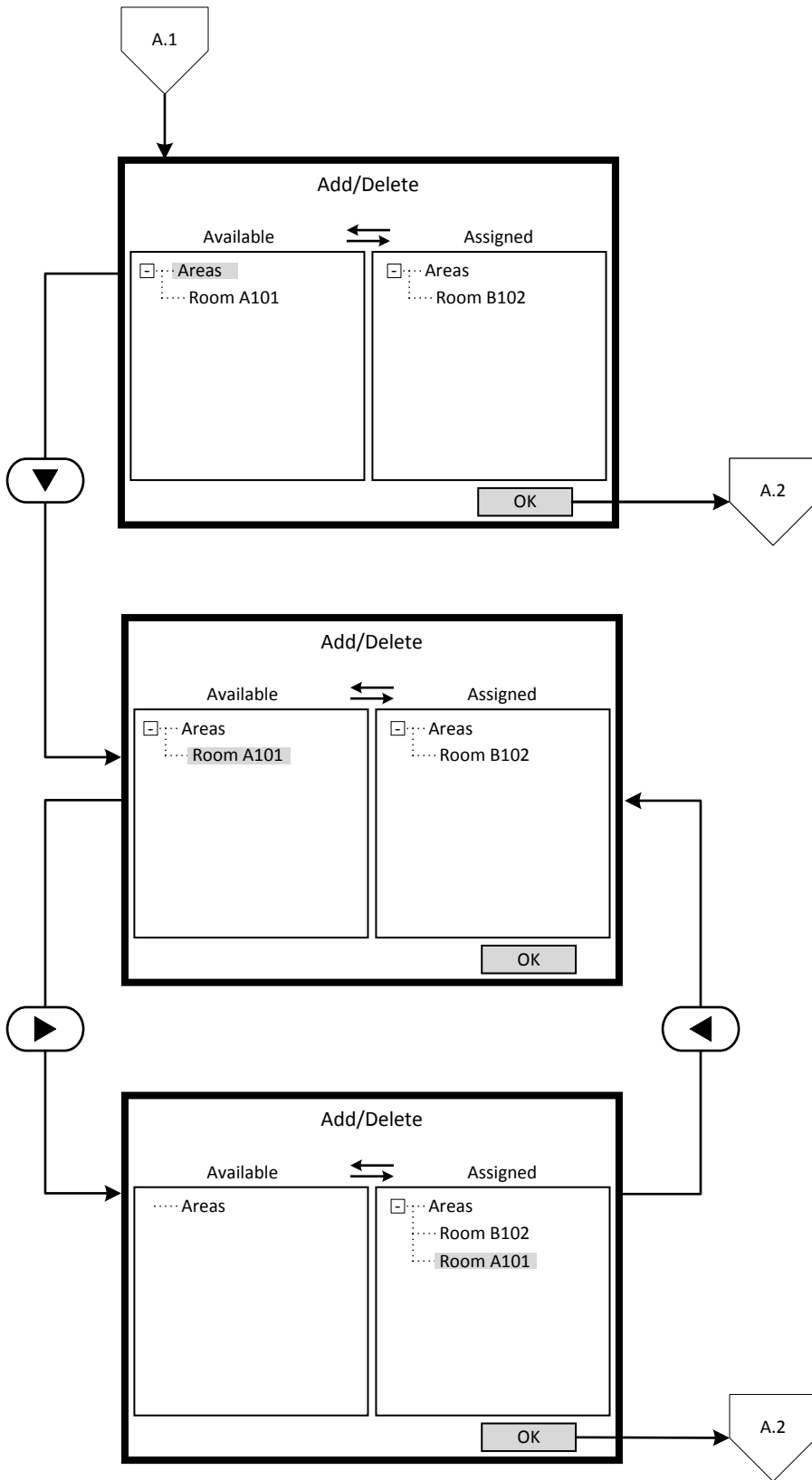

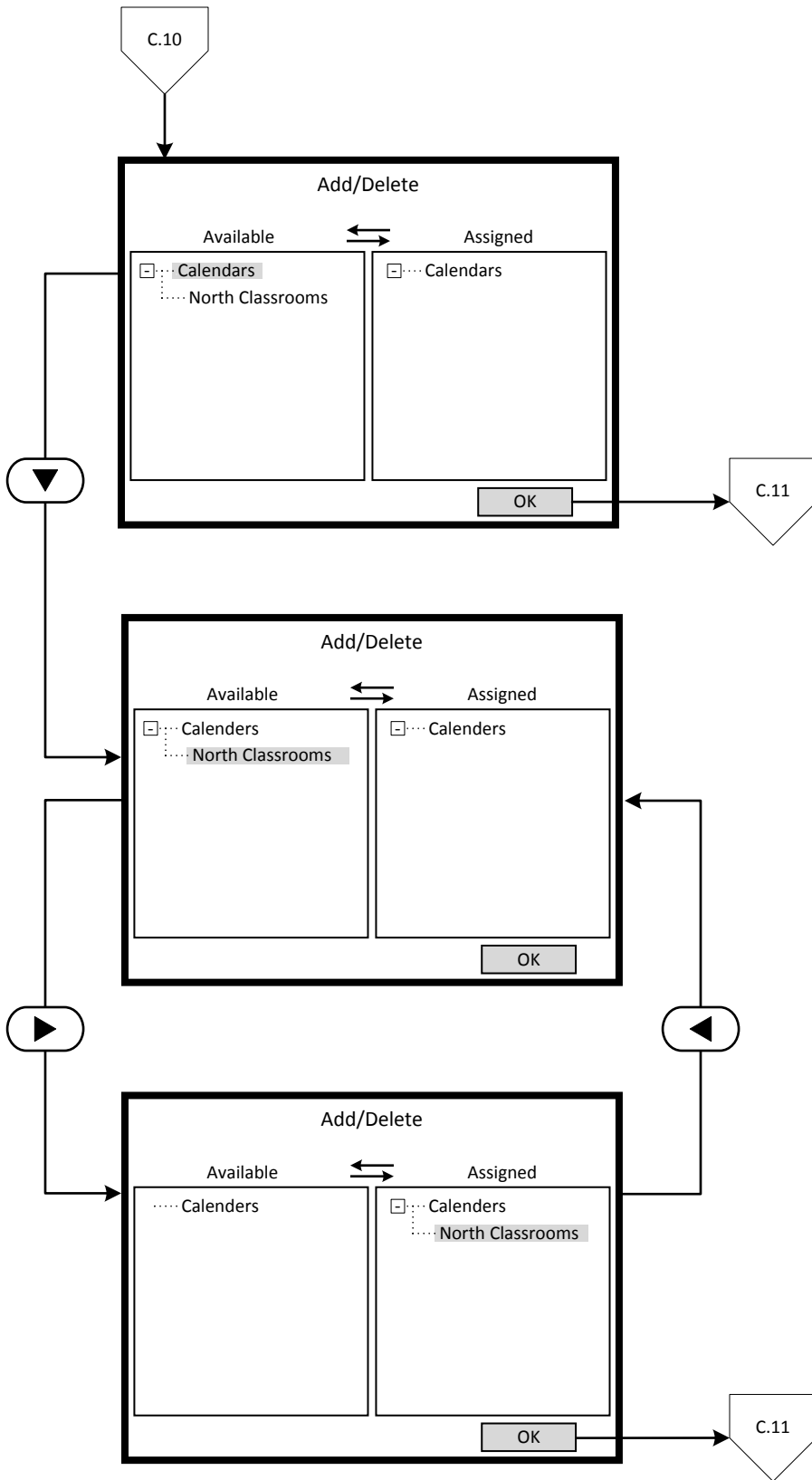

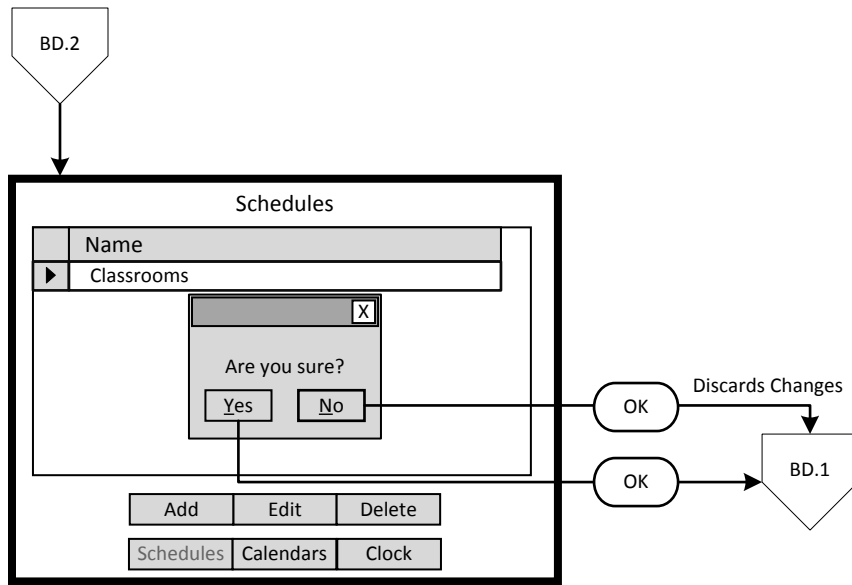



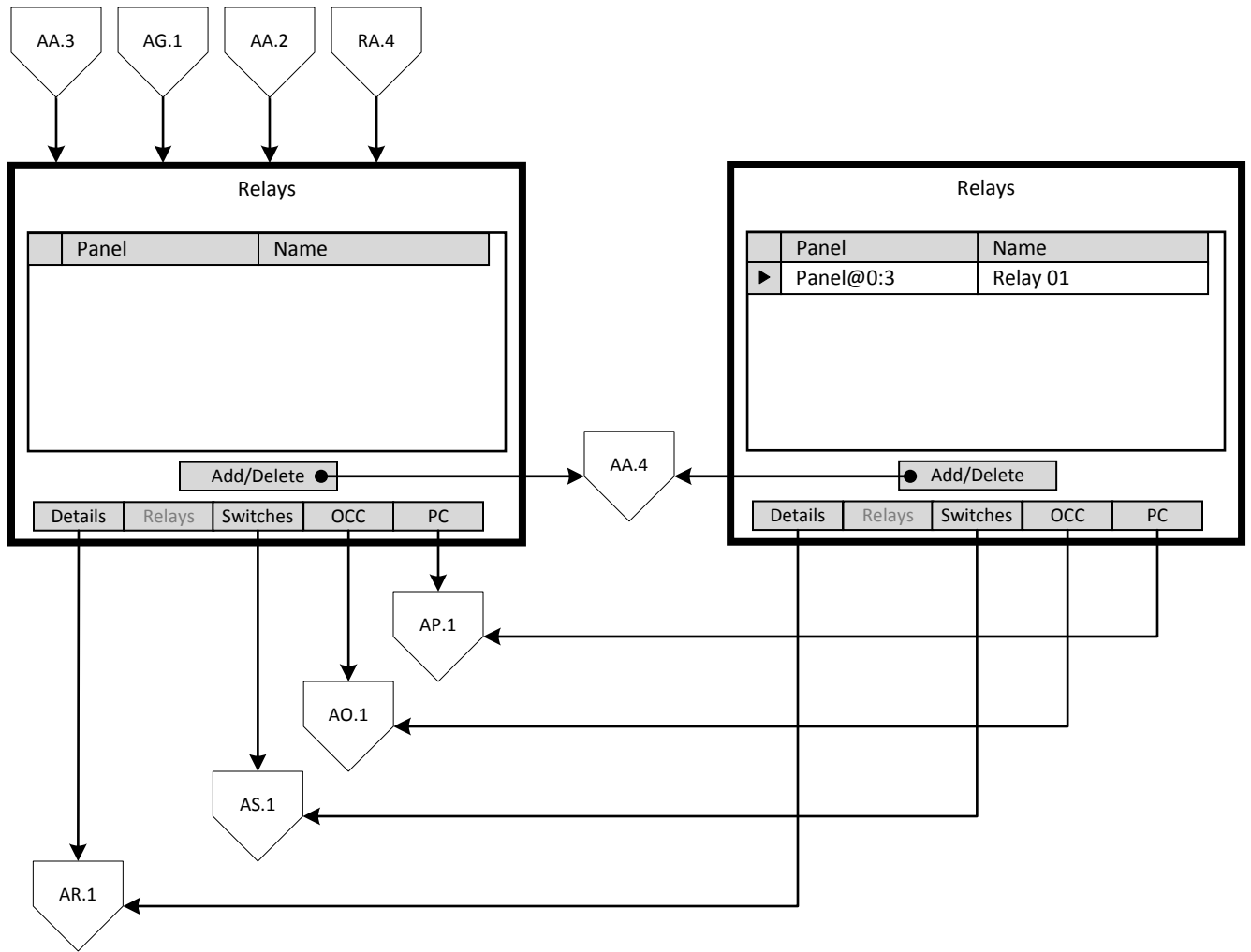

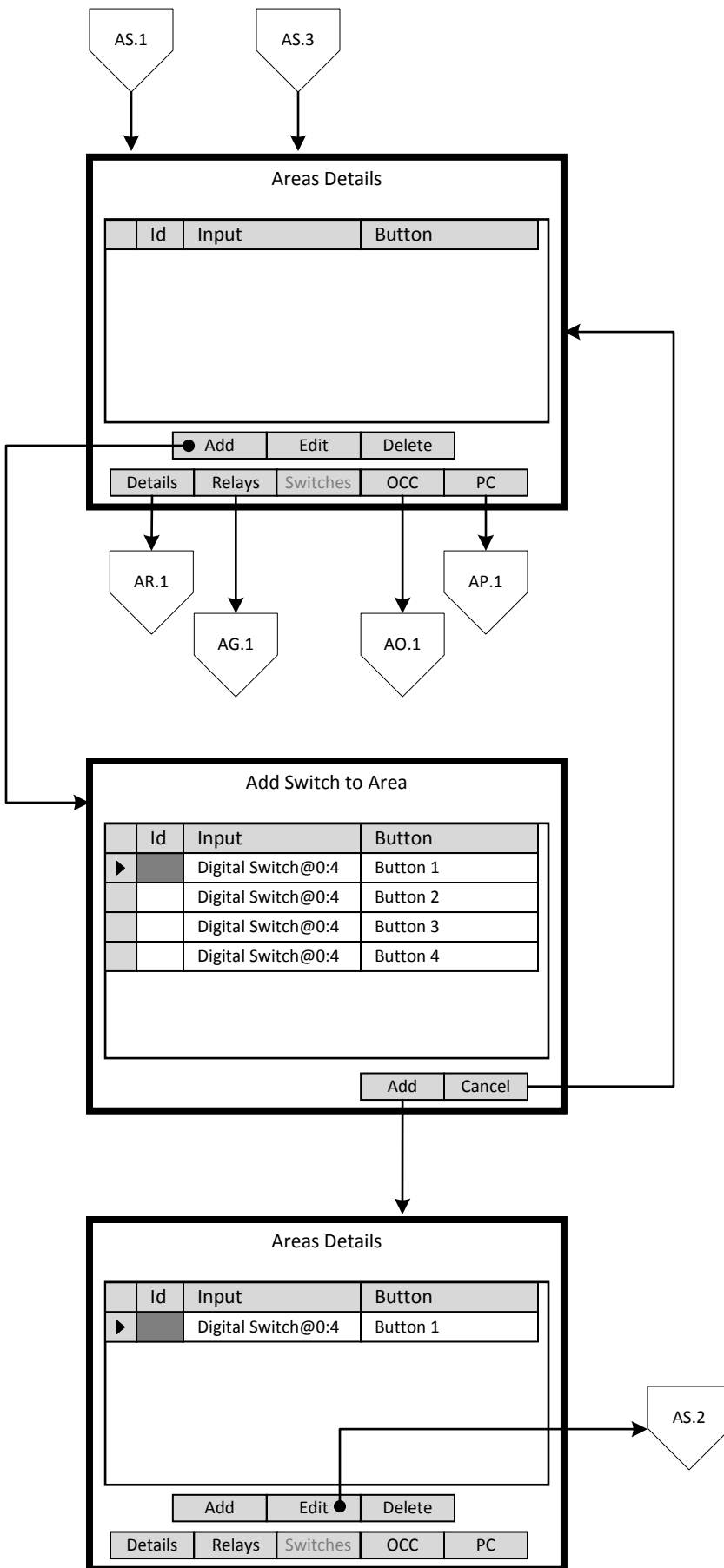

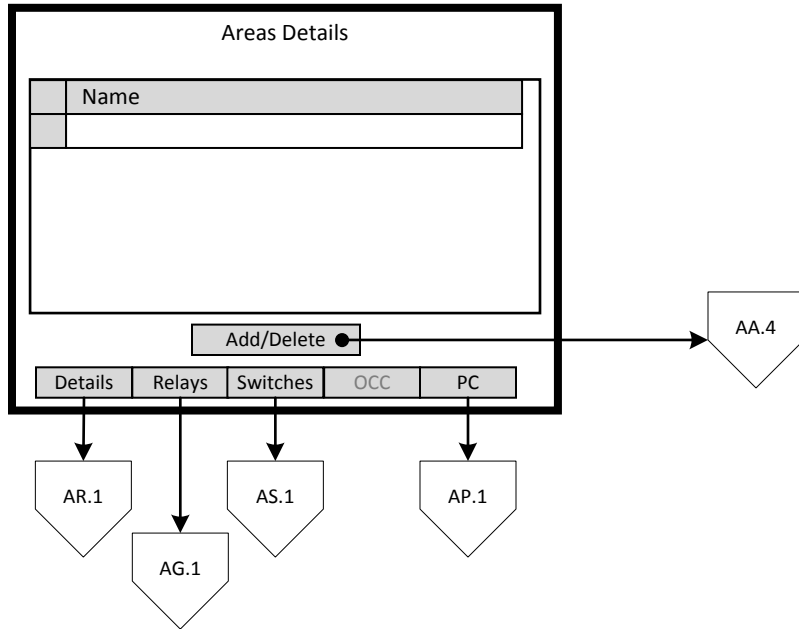
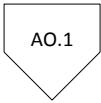

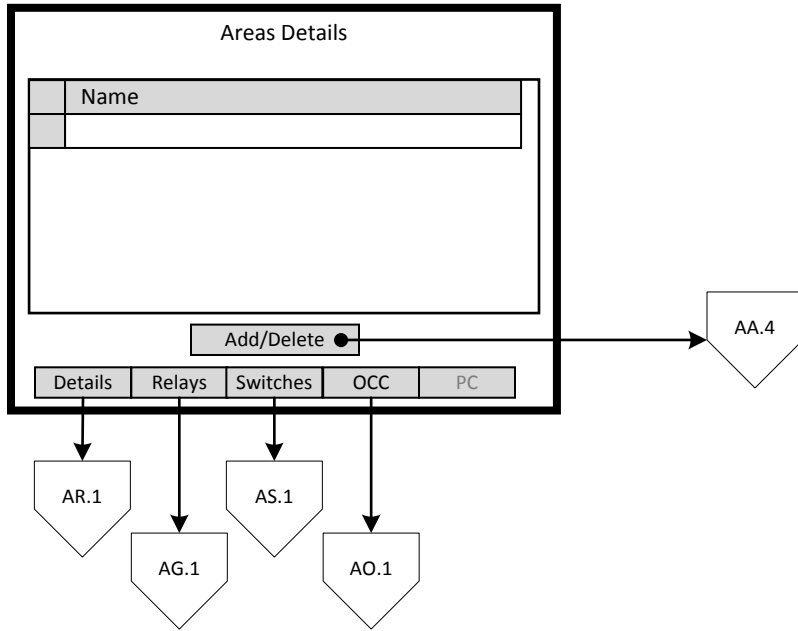
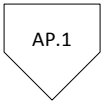

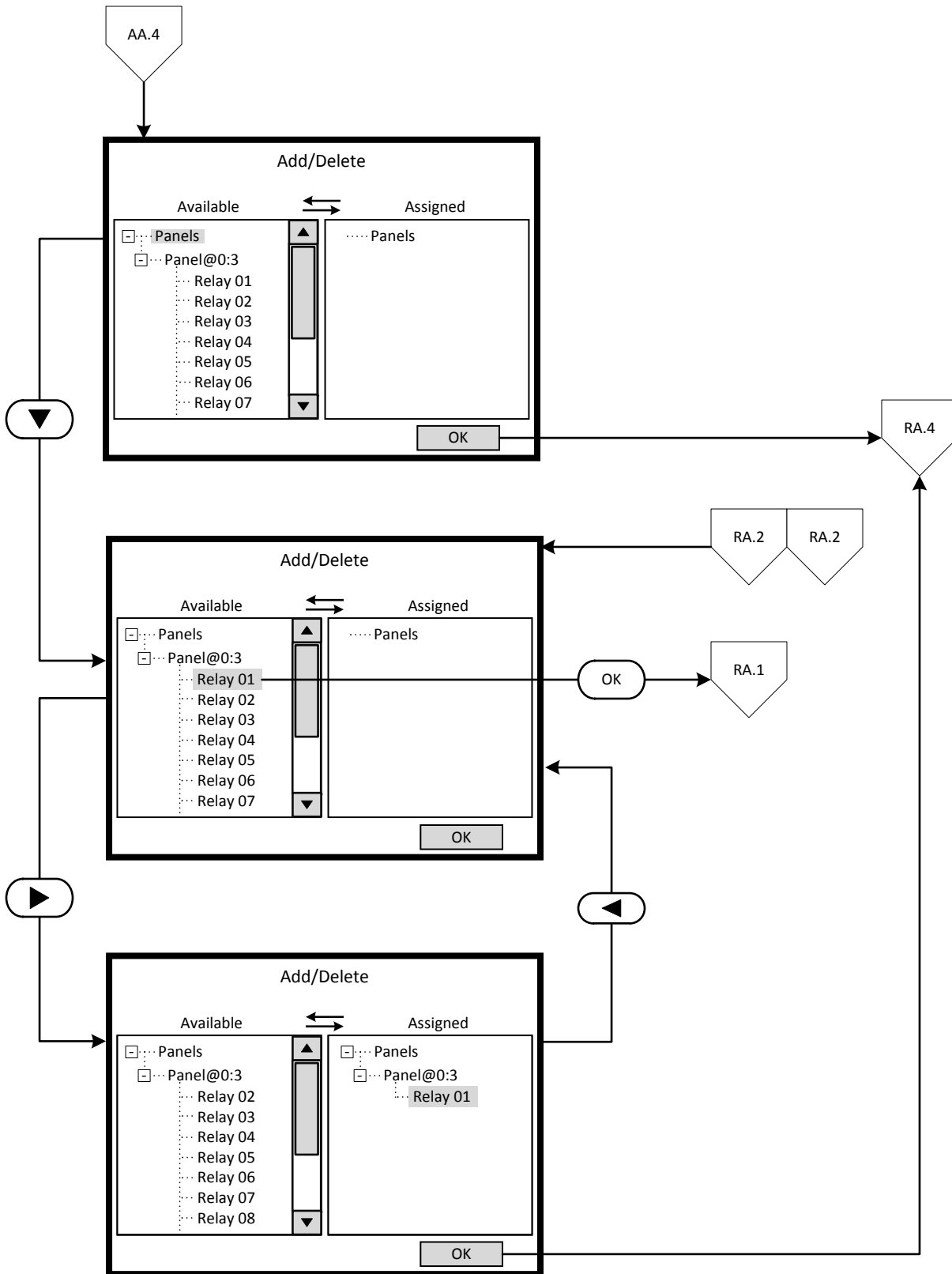

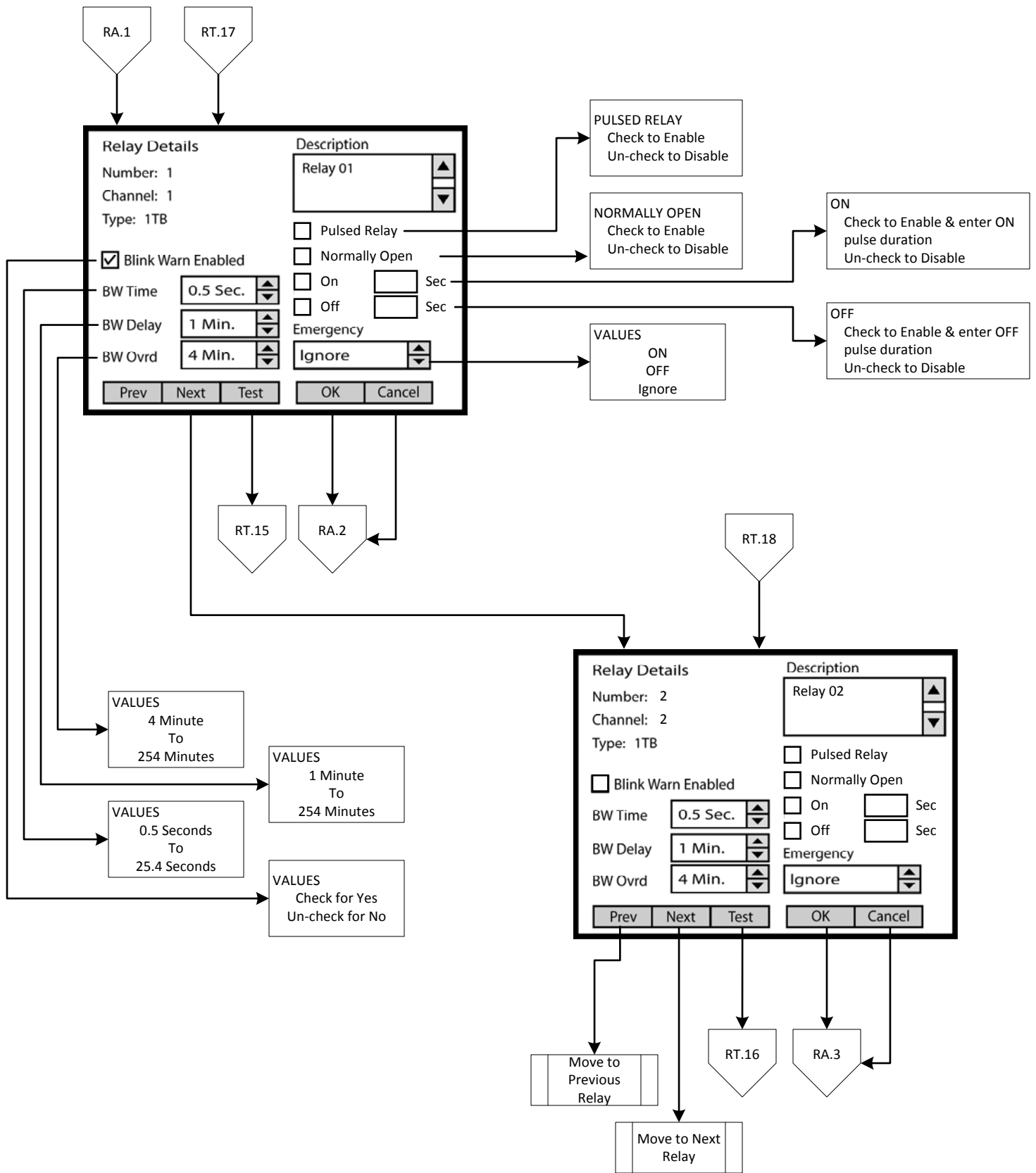

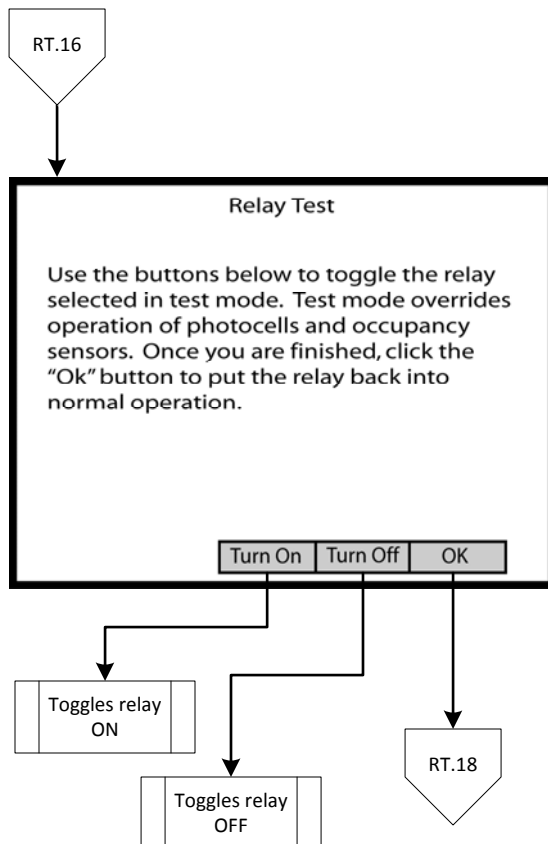
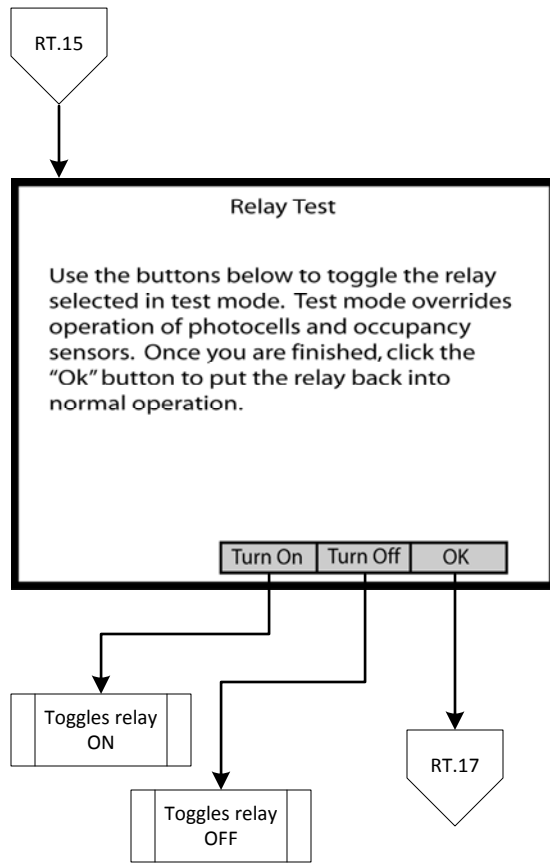

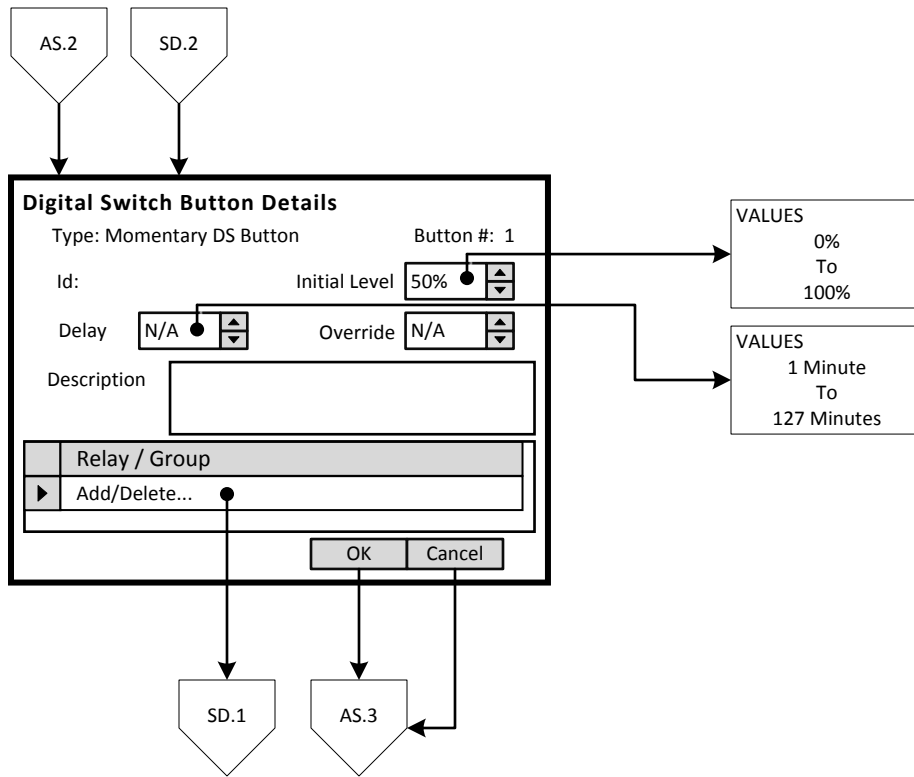



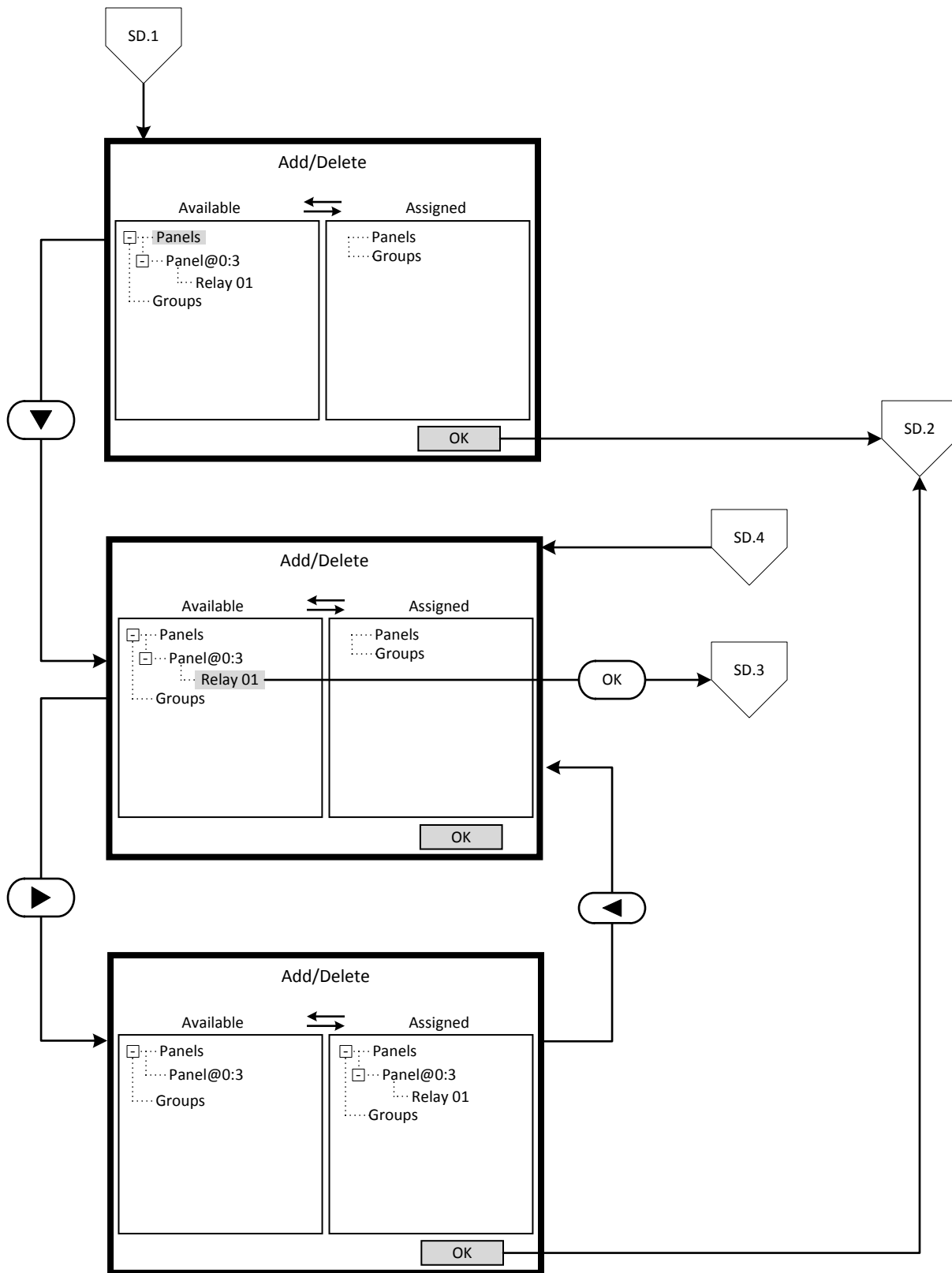

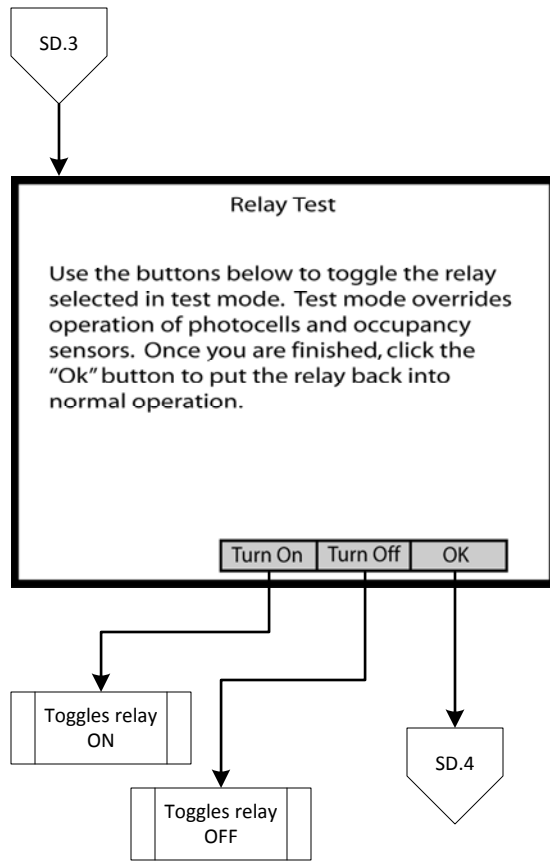

## Programming Concepts

The main phases of programming the GreenMAX are:

- Build Schedules
- Populate Low Voltage Inputs
- Configure Digital Switches
- Build Areas

### Overview of Schedules

Programming operation of the GreenMAX is based on running Schedules. A Schedule can be considered a default seven (7) day pattern of operation

The implementation of the features and functions of GreenMAX is driven by the Scheduling System. This powerful tool provides control of the interaction between system input devices and their associated relays. The list of input devices include occupancy sensors, photocells, and switches.

The main building blocks of programming the Scheduling System:

- Agendas
- Behaviors
- Exception Calendars
- Schedules
- Astronomical Clock
- Time/Date Clock

## Definitions

Agenda	A pattern of Behaviors or list of Behavior Transitions that cover a 24 hour period. Each Agenda provides a maximum of 24 transitions for that period. Time between Transitions can be as short as one minute apart.
Behavior	A predefined control scheme that, when applied to an Area, establishes the interactive priorities among the input devices in that Area. Certain behaviors can change device settings at the time of Transition. The system will stay in the last Behavior until the next Transition is triggered.
Behavior Transition	A point in time that an Agenda triggers an operational change to new Behavior. The transition will only occur in an Area that is assigned to the schedule.
Exceptions Calendar	This is a list of dates that requires specific Agenda that is a departure from the scheduled default Agenda. For example, a list of Holidays that require a unique Agenda.
Schedule	This is a series of seven Agendas corresponding with the days of the week. It is the fundamental or default week that will routinely function. Agendas for dates listed on the Exceptions Calendar will override the default Agenda for that day.
Low Voltage Inputs	Devices that interface with the controlled environment to detect the presence or absence of conditions or people. Devices include occupancy sensors, photocells, low voltage switches, and contact closures. These devices connect to a port on the Low Voltage input card and operate at +24vdc. The input signals from the devices are measured at 0 to +10vdc and can be analog or binary.
Analog Input	This is a signal from a device that will vary in voltage directly proportional to devices' measured detection value. For example, a photocell is used to measure the light level in a space. Full range or maximum light level at the photocell will measure +10vdc and conversely no light level will be 0vdc.
Binary Input	This is a signal from a device that will only have two state or measured voltage levels. Typically these values will be +10vdc (full On signal) or 0vdc (Off signal). An occupancy sensor provides this type of signal, On when occupant is present or Off when no occupant is sensed.
Astronomical Clock	This timing feature tracks the Sunset and Sunrise in the Northern hemisphere as it seasonally changes. The times change or update on a weekly basis. This allows Behavior Transitions based on Sunset and Sunrise times. Offsets from these times are also programmable.
Time/Date Clock	This is the main system clock used to coordinate all Behavior Transitions.

## Definitions

Digital Switch	A manual control switch station that connects to the system via the LumaCan network. They are available in one, two, and four button configurations. Each button on the Digital Switch is programmable for a variety of functions and features.
LumaCan	This is the communication network platform that interconnects all components in the system.
Low Voltage Input Board	This board provides the connection of Low Voltage devices to the system. This board is available in two sizes, 8 and 16 independent inputs.

### Programming Exercise: Classroom

This exercise will be used to demonstrate the steps required to program a GreenMAX system. A school has been selected as the setting for this exercise.

The following details apply to this exercise:

- There are multiple classrooms in the school that will operate on the same schedule.
- All exterior lights will operate on their own schedule.

#### Classroom Schedule

##### **Monday to Friday**

8:00am	Teaching Time	Lights will be controlled by their respective devices: Occupancy Sensors – 10 minute delay Photocells – 35 footcandle target Digital Switches – On/Off, no delay, no blink warn	B10
5:00pm	Janitor Mode	Lights will be controlled by: Occupancy Sensors only – 20 minute delay	B5
11:00pm	OFF sweep	Lights will be turned OFF	B7
11:01pm	Security	Lights will be controlled by: Occupancy Sensors only – 1 minute delay	B5

##### **Saturday & Sunday**

8:00am	Janitor Mode	Lights will be controlled by: Occupancy Sensors only – 20 minute delay	B5
11:00pm	OFF sweep	Lights will be turned OFF	B7
11:01pm	Security	Lights will be controlled by: Occupancy Sensors only – 1 minute delay	B5

#### **Exceptions**

April 11 to April 15, each year

11:01pm	Security	Lights will be controlled by: Occupancy Sensors only – 1 minute delay	B5
---------	----------	--	----

#### Exterior Schedule

SS +30m	Turn ON	Lights will be turned ON	B6
SR +30m	Turn OFF	Lights will be turned OFF	B7

Key  
 <Add> On screen button.  
 -Name- Label of on screen entry field  
 NEXT Button on keypad  
 Details Screen Name

**Step 1: Create a Schedule**

Programming operation of the GreenMAX is based on running Schedules. A Schedule can be considered a default seven (7) day pattern of operation.

The following rules apply:

- An Area requires a Schedule to operate.
- Only one Schedule can be assigned to an Area.
- A Schedule can be assigned to multiple Areas.
- Schedules reside in the GreenMAX system and can be accessed through the Handheld Display Unit (HDU).

**Step 1.1**

To create a Schedule, enter the <Control> section of the Handheld Display Unit (HDU) software.

Understanding the Screen

There are three sections of the HDU software. The sections under the buttons are:

- <Monitor> - Used to check the system time/date, relay status
- <Control> - Access Scheduling
- <Config> - Configuration of system including set-up of Areas

**Step 1.2**

The first <Control> HDU screen lists the existing Schedules available in your GreenMAX System. The screen shown indicates that there are no Schedules available or created.

By navigating to <Add> and pressing OK, this will initiate the creation of a Schedule.

Other Options

To modify an existing Schedule, highlight the appropriate Schedule on the list. Navigate to <Edit> and press OK, to initiate the modification of the selected Schedule.

To delete an existing Schedule, highlight the appropriate Schedule on the list. Navigate to <Delete> and press OK, to erase the selected Schedule.

**Step 1.3**

The screen is entered with the -Name- field highlighted. Enter the desired name of your Schedule using the alpha numeric keypad of the HDU. When complete, press the NEXT button on the navigation keypad. The cursor will advance to the <Monday> button.

Understanding the Screen

The label value of "Inactive" shown on the <Monday> button indicates that there is currently no Behavior transitions programmed for this day. The same is true for all days, Monday through Sunday, of this schedule.

There are no Exception Calendars associated with this Schedule.

This Schedule has not been assigned to any Areas.

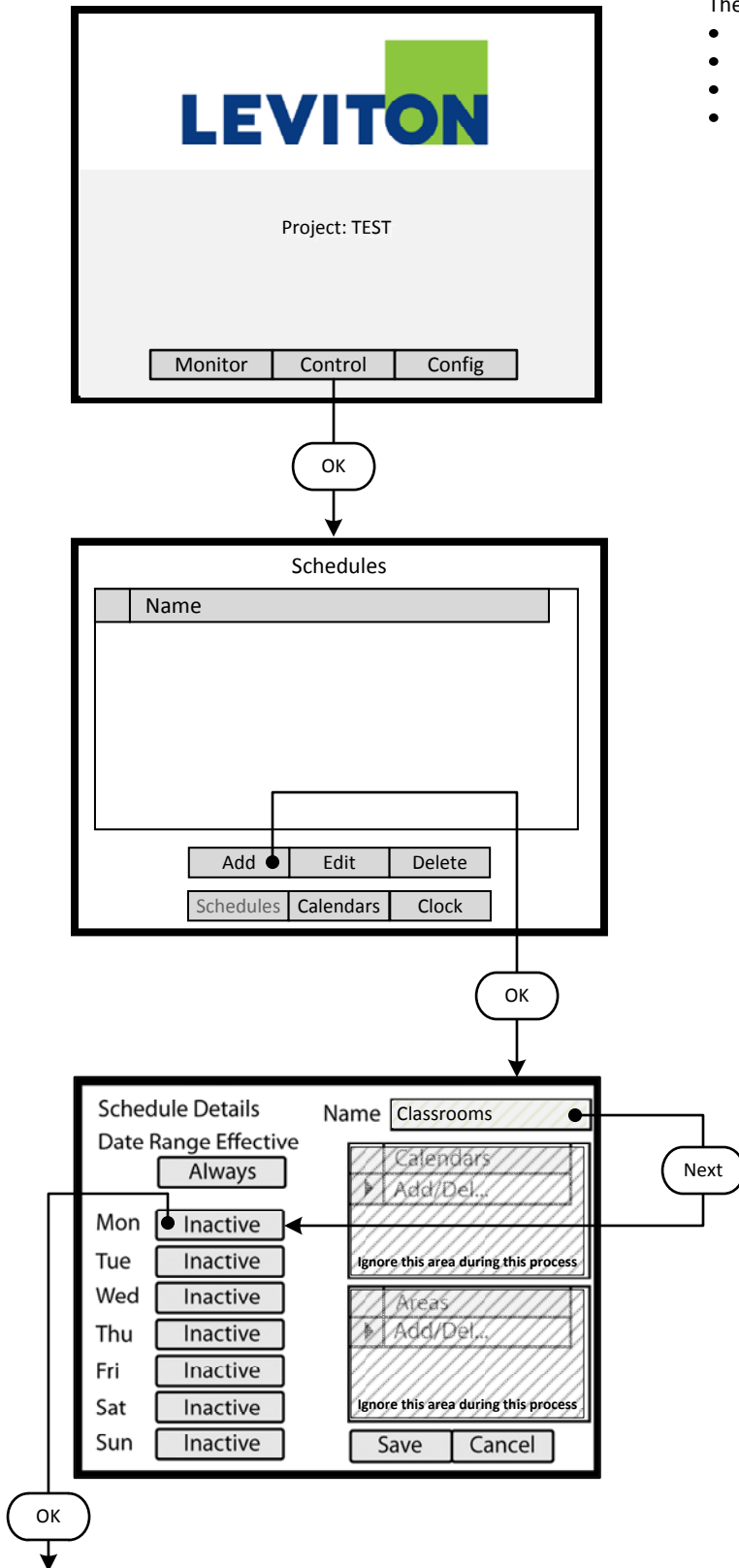

- Key
- <Add> On screen button.
- Name- Label of onscreen entry field
- NEXT Button on keypad
- Details Screen Name

**Agenda For Schedule: Classrooms**

Start Time	Behavior	
▶	●	Add

Mon  
 Tue  
 Wed  
 Thu  
 Fri  
 Sat  
 Sun

OK

**Agenda Behavior Transition Detail**

Transition to behavior: Behavior 1

Absolute Time 12:00 PM

Offset N/A N/A N/A

Swt Delay N/A BW Time N/A

Occ Delay N/A BW Delay N/A

PC Delay N/A BW Ovrld N/A

Next

Next

**Agenda Behavior Transition Detail**

Transition to behavior: Behavior 10

Absolute Time 8:00 AM

Offset N/A N/A N/A

Swt Delay N/A BW Time N/A

Occ Delay 10 BW Delay N/A

PC Delay N/A BW Ovrld N/A

Next

**Step 1.4**

The screen is entered at the first line of the Agenda. There are a total of 24 Behavior Transition times available per day. Clicking OK will advance to the Behavior Transition Detail screen.

Understanding the Screen

*This Agenda only applies to Monday, as shown here.*

<OK> - Will save the settings or changes

<Cancel> - Will discard the changes

**Step 1.5**

The Behavior Transition Detail screen is entered at the Behavior selection box. Use the UP or DOWN arrows to choose the desired Behavior. Consultate the Behavior chart in the Manual for descriptions. For this example change to Behavior 10.

Understanding the Screen

<Offset> provides access to Sunrise and Sunset settings for Astronomical clock times.

-BW Time-, -BW Delay-, -BW Ovrld- - These are the Blinkwarn settings that apply to this Behavior Transition only. They will override the Global Blinkwarn Settings set in the System Settings section.

**Step 1.6**

Use a combination of the UP and DOWN arrows as well as the NEXT button to change the time to 8:00 AM. When complete, use the NEXT button to navigate to the -Occ Delay- field. Adjust this setting to 10 minutes.

Understanding the Screen

-Swt Delay- is used if the switch in the associated Area is to function as a Timed Off switch. This is the amount of time the lights will stay On after a button press, and before they will turn Off.

-Occ Delay- This is the amount of time the lights will stay On after the occupancy sensor does not detect occupancy and before they will turn Off.

-PC Delay- This is the amount of time the lights will stay On after the photocell trigger point is exceeded and before they will turn Off.

- Key
- <Add> On screen button.
- Name- Label of onscreen entry field
- NEXT Button on keypad
- Details Screen Name

**Agenda For Schedule: Classrooms**

Start Time	Behavior	
8:00 AM	Behavior 10	<input checked="" type="checkbox"/> Mon
	Add	<input type="checkbox"/> Tue
		<input type="checkbox"/> Wed
		<input type="checkbox"/> Thu
		<input type="checkbox"/> Fri
		<input type="checkbox"/> Sat
		<input type="checkbox"/> Sun

OK Cancel

OK

**Agenda Behavior Transition Detail**

Transition to behavior: Behavior 1

Absolute Time 12:00 PM

Offset N/A N/A N/A

Swt Delay N/A BW Time N/A

Occ Delay N/A BW Delay N/A

PC Delay N/A BW Ovrđ N/A

OK Cancel

Next

Next

**Agenda Behavior Transition Detail**

Transition to behavior: Behavior 5

Absolute Time 5:00 PM

Offset N/A N/A N/A

Swt Delay N/A BW Time N/A

Occ Delay 20 BW Delay N/A

PC Delay N/A BW Ovrđ N/A

OK Cancel

Next

Next

**Step 1.7**

Navigate to the Add line of the list, in this case the second line. Click OK to advance to the Behavior Transition Detail screen.

Understanding the Screen

*This Agenda only applies to Monday, as shown here. A transition to Behavior 10 will occur Monday at 8:00 AM.*

**Step 1.8**

The Behavior Transition Detail screen is entered at the Behavior selection box. Use the UP or DOWN arrows to choose the desired Behavior. Consultate the Behavior chart in the Manual for descriptions. For this example change to Behavior 5.

**Step 1.9**

Use a combination of the UP and DOWN arrows as well as the NEXT button to change the time to 5:00 PM. When complete, use the NEXT button to navigate to the -Occ Delay- field. Enter the value of 20 minutes.



- Key
- <Add> On screen button.
- Name- Label of onscreen entry field
- NEXT Button on keypad
- Details Screen Name

**Agenda For Schedule: Classrooms**

Start Time	Behavior	
8:00 AM	Behavior 10	<input checked="" type="checkbox"/> Mon
5:00 PM	Behavior 5	<input type="checkbox"/> Tue
	Add	<input type="checkbox"/> Wed
		<input type="checkbox"/> Thu
		<input type="checkbox"/> Fri
		<input type="checkbox"/> Sat
		<input type="checkbox"/> Sun

OK Cancel

OK

**Agenda Behavior Transition Detail**

Transition to behavior: Behavior 1

Absolute Time 12:00 PM

Offset N/A N/A N/A

Swt Delay N/A BW Time N/A

Occ Delay N/A BW Delay N/A

PC Delay N/A BW Ovrd N/A

OK Cancel

Next

Next

**Agenda Behavior Transition Detail**

Transition to behavior: Behavior 7

Absolute Time 11:00 PM

Offset N/A N/A N/A

Swt Delay N/A BW Time N/A

Occ Delay N/A BW Delay N/A

PC Delay N/A BW Ovrd N/A

OK Cancel

Next

**Step 1.10**

Navigate to the Add line of the list, in this case the second line. Click OK to advance to the Behavior Transition Detail screen.

Understanding the Screen

*This Agenda only applies to Monday, as shown here.  
A transition to Behavior 10 will occur Monday at 8:00 AM.  
A transition to Behavior 5 will occur Monday at 11:00 PM.*

**Step 1.11**

The Behavior Transition Detail screen is entered at the Behavior selection box. Use the UP or DOWN arrows to choose the desired Behavior. Consultate the Behavior chart in the Manual for descriptions. For this example change to Behavior 7.

**Step 1.12**

Use a combination of the UP and DOWN arrows as well as the NEXT button to change the time to 11:00 PM. When complete, use the NEXT button to navigate to the <OK> onscreen button.

- Key
- <Add> On screen button.
- Name- Label of onscreen entry field
- NEXT Button on keypad
- Details Screen Name

**Agenda For Schedule: Classrooms**

Start Time	Behavior	
8:00 AM	Behavior 10	<input checked="" type="checkbox"/> Mon
5:00 PM	Behavior 5	<input type="checkbox"/> Tue
11:00 PM	Behavior 7	<input type="checkbox"/> Wed
▶	●	Add
		<input type="checkbox"/> Thu
		<input type="checkbox"/> Fri
		<input type="checkbox"/> Sat
		<input type="checkbox"/> Sun

OK Cancel

OK

**Agenda Behavior Transition Detail**

Transition to behavior: Behavior 1

Absolute Time 12:00 PM

Offset N/A N/A N/A

Swt Delay N/A BW Time N/A

Occ Delay N/A BW Delay N/A

PC Delay N/A BW Ovrđ N/A

OK Cancel

Next

Next

**Agenda Behavior Transition Detail**

Transition to behavior: Behavior 5

Absolute Time 11:01 PM

Offset N/A N/A N/A

Swt Delay N/A BW Time N/A

Occ Delay 1 BW Delay N/A

PC Delay N/A BW Ovrđ N/A

OK Cancel

Next

Next

**Step 1.13**

Navigate to the Add line of the list, in this case the second line. Click OK to advance to the Behavior Transition Detail screen.

Understanding the Screen

*This Agenda only applies to Monday, as shown here.  
 A transition to Behavior 10 will occur Monday at 8:00 AM.  
 A transition to Behavior 5 will occur Monday at 5:00 PM.  
 A transition to Behavior 7 will occur Monday at 11:00 PM.*

**Step 1.14**

The Behavior Transition Detail screen is entered at the Behavior selection box. Use the UP or DOWN arrows to choose the desired Behavior. Consultate the Behavior chart in the Manual for descriptions. For this example change to Behavior 5.

**Step 1.15**

Use a combination of the UP and DOWN arrows as well as the NEXT button to change the time to 11:01 PM. When complete, use the NEXT button to navigate to the -Occ Delay- field. Adjust this setting to 1 minute.

- Key
- <Add> On screen button.
- Name- Label of onscreen entry field
- NEXT Button on keypad
- Details Screen Name

**Agenda For Schedule: Classrooms**

Start Time	Behavior	
8:00 AM	Behavior 10	<input checked="" type="checkbox"/> Mon
5:00 PM	Behavior 5	<input type="checkbox"/> Tue
11:00 PM	Behavior 7	<input type="checkbox"/> Wed
11:01 PM	Behavior 5	<input type="checkbox"/> Thu
▶	●	Add

Fri
  Sat
  Sun

Next

**Agenda For Schedule: Classrooms**

Start Time	Behavior	
8:00 AM	Behavior 10	<input checked="" type="checkbox"/> Mon
5:00 PM	Behavior 5	<input type="checkbox"/> Tue
11:00 PM	Behavior 7	<input type="checkbox"/> Wed
11:01 PM	Behavior 5	<input type="checkbox"/> Thu
▶	●	Add

Fri
  Sat
  Sun

Next

OK

**Agenda For Schedule: Classrooms**

Start Time	Behavior	
8:00 AM	Behavior 10	<input checked="" type="checkbox"/> Mon
5:00 PM	Behavior 5	<input checked="" type="checkbox"/> Tue
11:00 PM	Behavior 7	<input checked="" type="checkbox"/> Wed
11:01 PM	Behavior 5	<input checked="" type="checkbox"/> Thu
▶	●	Add

Sat
  Sun

**Step 1.16**

To apply this Agenda or pattern of Behavior to each day of the week press Next to advance to the Day column.

Understanding the Screen

*This Agenda only applies to Monday, as shown here.*  
 A transition to Behavior 10 will occur Monday at 8:00 AM.  
 A transition to Behavior 5 will occur Monday at 5:00 PM.  
 A transition to Behavior 7 will occur Monday at 11:00 PM.  
 A transition to Behavior 5 will occur Monday at 11:01 PM.

**Step 1.17**

Press Next to the -Tuesday- check box.  
 Press -OK- to check the box, this will add Tuesday to the active list.

Repeat this button press combination to fill all check boxes (Mon thru Fri)

**Step 1.18**

Use a combination of the NEXT and OK to fill in the Tuesday through Friday check boxes.

Understanding the Screen

*This Agenda only applies to Monday through Friday.*  
 A transition to Behavior 10 will occur Monday at 8:00 AM.  
 A transition to Behavior 5 will occur Monday at 5:00 PM.  
 A transition to Behavior 7 will occur Monday at 11:00 PM.  
 A transition to Behavior 5 will occur Monday at 11:01 PM.

- Key
- <Add> On screen button.
- Name- Label of onscreen entry field
- NEXT Button on keypad
- Details Screen Name

**Step 1.19**

To save the Schedule, press the NEXT button on the navigation keypad to advance to the <Save> button.

Understanding the Screen

The label value of "Inactive" shown on the <Saturday> and <Sunday> button indicates that there are currently no Behavior transitions programmed for this day.

The "MTWTF--" on the <Monday> through <Friday> indicate that the same Agenda applies to each of these days.

There are no Exception Calendars associated with this Schedule.

This Schedule has not been assigned to any Areas.

**Step 1.20**

The Classrooms Schedule must be modified to include a specific Agenda for both Saturday and Sunday. Highlight the Classroom Schedule on the list of available Schedules in the GreenMAX system. Navigate to the <Edit> button by pressing NEXT and then press OK.

Other Options

To add a new Schedule, navigate to <Add> and press OK, to initiate the addition of a Schedule.

To delete an existing Schedule, highlight the appropriate Schedule on the list. Navigate to <Delete> and press OK, to erase the selected Schedule.

OK

**Step 1.21**

The screen is entered in the -Name- button highlighted. Navigate by pressing the NEXT button on the navigation keypad to advance to the <Saturday> button.

- Key
- <Add> On screen button.
- Name- Label of onscreen entry field
- NEXT Button on keypad
- Details Screen Name

**Agenda For Schedule: Classrooms**

Start Time	Behavior	
▶	●	Add

Mon  
 Tue  
 Wed  
 Thu  
 Fri  
 Sat  
 Sun

OK

**Agenda Behavior Transition Detail**

Transition to behavior: Behavior 1

Absolute Time 12:00 PM

Offset N/A N/A N/A

Swt Delay N/A BW Time N/A

Occ Delay N/A BW Delay N/A

PC Delay N/A BW Ovrđ N/A

Next

Next

**Agenda Behavior Transition Detail**

Transition to behavior: Behavior 5

Absolute Time 8:00 AM

Offset N/A N/A N/A

Swt Delay N/A BW Time N/A

Occ Delay 10 BW Delay N/A

PC Delay N/A BW Ovrđ N/A

Next

Next

**Step 1.22**

The screen is entered at the first line of the Agenda. There are a total of 24 Behavior Transition times available per day. Clicking OK will advance to the Behavior Transition Detail screen.

Understanding the Screen

*This Agenda only applies to Saturday, as shown here.*

<OK> - Will save the settings or changes

<Cancel> - Will discard the changes

**Step 1.23**

The Behavior Transition Detail screen is entered at the Behavior selection box. Use the UP or DOWN arrows to choose the desired Behavior. Consultate the Behavior chart in the Manual for descriptions. For this example change to Behavior 5.

Understanding the Screen

*<Absolute Time> setting for a specific time of the day to trigger a Behavior Transition.*

**Step 1.24**

Use a combination of the UP and DOWN arrows as well as the NEXT button to change the time to 8:00 AM. When complete, use the NEXT button to navigate to the -Occ Delay- field. Adjust this setting to 10 minutes.

Understanding the Screen

*-Occ Delay- This is the amount of time the lights will stay On after the occupancy sensor does not detect occupancy and before they will turn Off.*

- Key
- <Add> On screen button.
- Name- Label of onscreen entry field
- NEXT Button on keypad
- Details Screen Name

**Agenda For Schedule: Classrooms**

Start Time	Behavior	
8:00 AM	Behavior 5	<input type="checkbox"/> Mon
	Add	<input type="checkbox"/> Tue
		<input type="checkbox"/> Wed
		<input type="checkbox"/> Thu
		<input type="checkbox"/> Fri
		<input checked="" type="checkbox"/> Sat
		<input type="checkbox"/> Sun

OK Cancel

OK

**Agenda Behavior Transition Detail**

Transition to behavior: Behavior 1

Absolute Time 12:00 PM

Offset N/A N/A N/A

Swt Delay N/A BW Time N/A

Occ Delay N/A BW Delay N/A

PC Delay N/A BW Ovrđ N/A

OK Cancel

Next

Next

**Agenda Behavior Transition Detail**

Transition to behavior: Behavior 7

Absolute Time 11:00 PM

Offset N/A N/A N/A

Swt Delay N/A BW Time N/A

Occ Delay 1 BW Delay N/A

PC Delay N/A BW Ovrđ N/A

OK Cancel

Next

**Step 1.25**

Navigate to the Add line of the list, in this case the second line. Click OK to advance to the Behavior Transition Detail screen.

Understanding the Screen

*This Agenda only applies to Saturday, as shown here. A transition to Behavior 5 will occur at 8:00 AM.*

**Step 1.26**

The Behavior Transition Detail screen is entered at the Behavior selection box. Use the UP or DOWN arrows to choose the desired Behavior. Consultate the Behavior chart in the Manual for descriptions. For this example change to Behavior 7.

Understanding the Screen

*<Absolute Time> setting for a specific time of the day to trigger a Behavior Transition.*

**Step 1.27**

Use a combination of the UP and DOWN arrows as well as the NEXT button to change the time to 11:00 PM. When complete, use the NEXT button to navigate to the -OK- field

- Key
- <Add> On screen button.
- Name- Label of onscreen entry field
- NEXT Button on keypad
- Details Screen Name

**Agenda For Schedule: Classrooms**

Start Time	Behavior	
8:00 AM	Behavior 5	<input type="checkbox"/> Mon
11:00 PM	Behavior 7	<input type="checkbox"/> Tue
▶ ●	Add	<input type="checkbox"/> Wed
		<input type="checkbox"/> Thu
		<input type="checkbox"/> Fri
		<input checked="" type="checkbox"/> Sat
		<input type="checkbox"/> Sun

OK

**Agenda Behavior Transition Detail**

Transition to behavior: Behavior 1

Absolute Time 12:00 PM ◀ ▶

Offset N/A ◀ ▶ N/A ◀ ▶ N/A ◀ ▶

Swt Delay N/A ◀ ▶ BW Time N/A ◀ ▶

Occ Delay N/A ◀ ▶ BW Delay N/A ◀ ▶

PC Delay N/A ◀ ▶ BW Ovrđ N/A ◀ ▶

Next

Next

**Agenda Behavior Transition Detail**

Transition to behavior: Behavior 5

Absolute Time 11:01 PM ◀ ▶

Offset N/A ◀ ▶ N/A ◀ ▶ N/A ◀ ▶

Swt Delay N/A ◀ ▶ BW Time N/A ◀ ▶

Occ Delay 1 ◀ ▶ BW Delay N/A ◀ ▶

PC Delay N/A ◀ ▶ BW Ovrđ N/A ◀ ▶

Next

Next

**Step 1.28**

Navigate to the Add line of the list, in this case the third line. Click OK to advance to the Behavior Transition Detail screen.

Understanding the Screen

*This Agenda only applies to Saturday, as shown here. A transition to Behavior 5 will occur at 8:00 AM. A transition to Behavior 7 will occur at 11:00 PM.*

**Step 1.29**

The Behavior Transition Detail screen is entered at the Behavior selection box. Use the UP or DOWN arrows to choose the desired Behavior. Consultate the Behavior chart in the Manual for descriptions. For this example change to Behavior 5.

Understanding the Screen

*<Absolute Time> setting for a specific time of the day to trigger a Behavior Transition.*

**Step 1.30**

Use a combination of the UP and DOWN arrows as well as the NEXT button to change the time to 11:01 PM. When complete, use the NEXT button to navigate to the -Occ Delay- field. Adjust this setting to 1 minute.

- Key
- <Add> On screen button.
- Name- Label of onscreen entry field
- NEXT Button on keypad
- Details Screen Name

**Agenda For Schedule: Classrooms**

Start Time	Behavior	
8:00 AM	Behavior 5	<input type="checkbox"/> Mon
11:00 PM	Behavior 7	<input type="checkbox"/> Tue
11:01 PM	Behavior 5	<input type="checkbox"/> Wed
▶	●	<input type="checkbox"/> Thu
	●	<input type="checkbox"/> Fri
	●	<input checked="" type="checkbox"/> Sat
	●	<input type="checkbox"/> Sun

Next

**Agenda For Schedule: Classrooms**

Start Time	Behavior	
8:00 AM	Behavior 5	<input type="checkbox"/> Mon
11:00 PM	Behavior 7	<input type="checkbox"/> Tue
11:01 PM	Behavior 5	<input type="checkbox"/> Wed
▶	●	<input type="checkbox"/> Thu
	●	<input type="checkbox"/> Fri
	●	<input checked="" type="checkbox"/> Sat
	●	<input type="checkbox"/> Sun

Next

OK

**Agenda For Schedule: Classrooms**

Start Time	Behavior	
8:00 AM	Behavior 5	<input type="checkbox"/> Mon
11:00 PM	Behavior 7	<input type="checkbox"/> Tue
11:01 PM	Behavior 5	<input type="checkbox"/> Wed
▶	●	<input type="checkbox"/> Thu
	●	<input type="checkbox"/> Fri
	●	<input checked="" type="checkbox"/> Sat
	●	<input checked="" type="checkbox"/> Sun

**Step 1.31**

To apply this Agenda or pattern of Behavior to each day of the week press Next to advance to the Day column.

Understanding the Screen

*This Agenda only applies to Monday, as shown here.  
 A transition to Behavior 5 will occur Monday at 8:00 AM.  
 A transition to Behavior 7 will occur Monday at 11:00 PM.  
 A transition to Behavior 5 will occur Monday at 11:01 PM.*

**Step 1.32**

Press Next to the -Sunday- check box.  
 Press OK to check the box, this will add Sunday to the active list.

**Step 1.33**

Navigate to the <OK> button to return to the Schedule detail screen.

Understanding the Screen

*This Agenda only applies to Saturday and Sunday.  
 A transition to Behavior 5 will occur Monday at 8:00 AM.  
 A transition to Behavior 7 will occur Monday at 11:00 PM.  
 A transition to Behavior 5 will occur Monday at 11:01 PM.*



Key	
<Add>	On screen button.
-Name-	Label of onscreen entry field
NEXT	Button on keypad
Details	Screen Name

Schedule Details

Name

Date Range Effective

Mon

Tue

Wed

Thu

Fri

Sat

Sun

Calendars

▶ Add/Del...

Areas

▶ Add/Del...

Save  Cancel

**Step 1.34**

To save the Schedule, press the NEXT button on the navigation keypad to advance to the <Save> button.

Understanding the Screen

The label value of "MTWTF--" on the <Monday> through <Friday> indicates that the same Agenda applies to each of these days.

The label value of "- - - - - SS" shown on the <Saturday> and <Sunday> button indicates that a specific Agenda applies to both of these days. This Agenda is different than the other days of the week.

There are no Exception Calendars associated with this Schedule.

This Schedule has not been assigned to any Areas.

- Key
- <Add> On screen button.
- Name- Label of onscreen entry field
- NEXT Button on keypad
- Details Screen Name

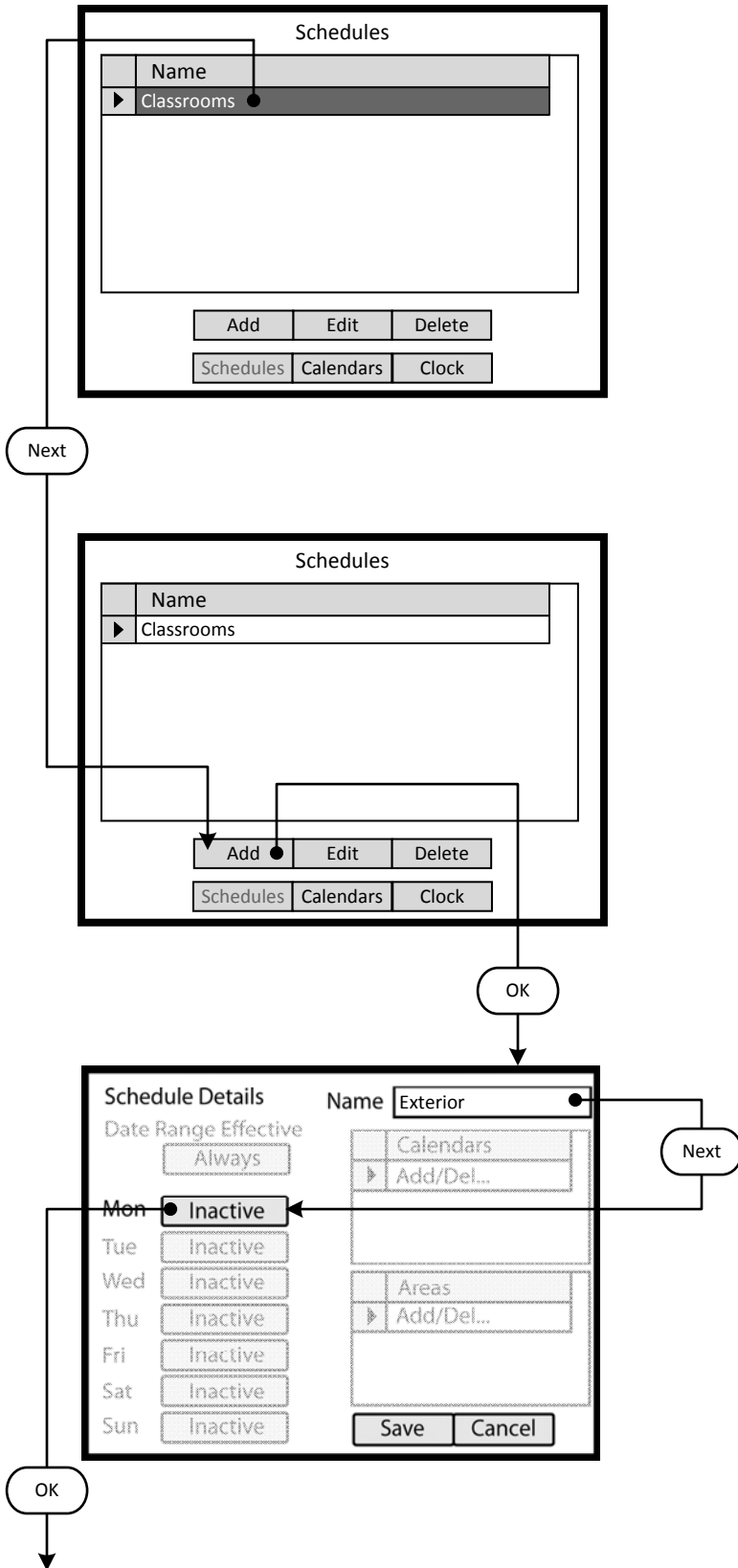

**Step 1.35**

The second schedule named Exterior must be created to accommodate the exterior lighting for Monday through Sunday. Navigate to the <Add> button by pressing NEXT and then press OK.

Other Options

To modify an existing Schedule, highlight the appropriate Schedule on the list. Navigate to <Edit> and press OK, to initiate the modification of the selected Schedule.

To delete an existing Schedule, highlight the appropriate Schedule on the list. Navigate to <Delete> and press OK, to erase the selected Schedule.

**Step 1.36**

Navigate to the <Add> button by pressing NEXT and then press OK.

**Step 1.37**

The screen is entered in the -Name- button highlighted. Navigate by pressing the NEXT button on the navigation keypad to advance to the <Monday> button.

- Key
- <Add> On screen button.
- Name- Label of onscreen entry field
- NEXT Button on keypad
- Details Screen Name

**Agenda For Schedule: Exterior**

Start Time	Behavior	
▶ ●	Add	<input checked="" type="checkbox"/> Mon
		<input type="checkbox"/> Tue
		<input type="checkbox"/> Wed
		<input type="checkbox"/> Thu
		<input type="checkbox"/> Fri
		<input type="checkbox"/> Sat
		<input type="checkbox"/> Sun

OK

**Agenda Behavior Transition Detail**

Transition to behavior: Behavior 1

Absolute Time 12:00 PM

Offset N/A N/A N/A

Swt Delay N/A BW Time N/A

Occ Delay N/A BW Delay N/A

PC Delay N/A BW Ovrdd N/A

Next

**Agenda Behavior Transition Detail**

Transition to behavior: Behavior 6

Absolute Time 12:00 AM

Offset N/A N/A N/A

Swt Delay N/A BW Time N/A

Occ Delay N/A BW Delay N/A

PC Delay N/A BW Ovrdd N/A

**Step 1.38**

The screen is entered at the first line of the Agenda. There are a total of 24 Behavior Transition times available per day. Clicking OK will advance to the Behavior Transition Detail screen.

Understanding the Screen

*This Agenda only applies to Monday, as shown here.*

<OK> - Will save the settings or changes

<Cancel> - Will discard the changes

**Step 1.39**

The Behavior Transition Detail screen is entered at the Behavior selection box. Use the UP or DOWN arrows to choose the desired Behavior. Consultate the Behavior chart in the Manual for descriptions. For this example change to Behavior 6.

Understanding the Screen

<Offset> provides access to Sunrise and Sunset settings for Astronomical clock times.

-BW Time-, -BW Delay-, -BW Ovrdd- - These are the Blinkwarn settings that apply to this Behavior Transition only. They will override the Global Blinkwarn Settings set in the System Settings section.

**Step 1.40**

Use the NEXT button to navigate to the -Absolute Time- check button.

Use the DOWN arrow to move to the -Offset- check button. Press OK to activate the -Offset- setting.

- Key
- <Add> On screen button.
- Name- Label of onscreen entry field
- NEXT Button on keypad
- Details Screen Name

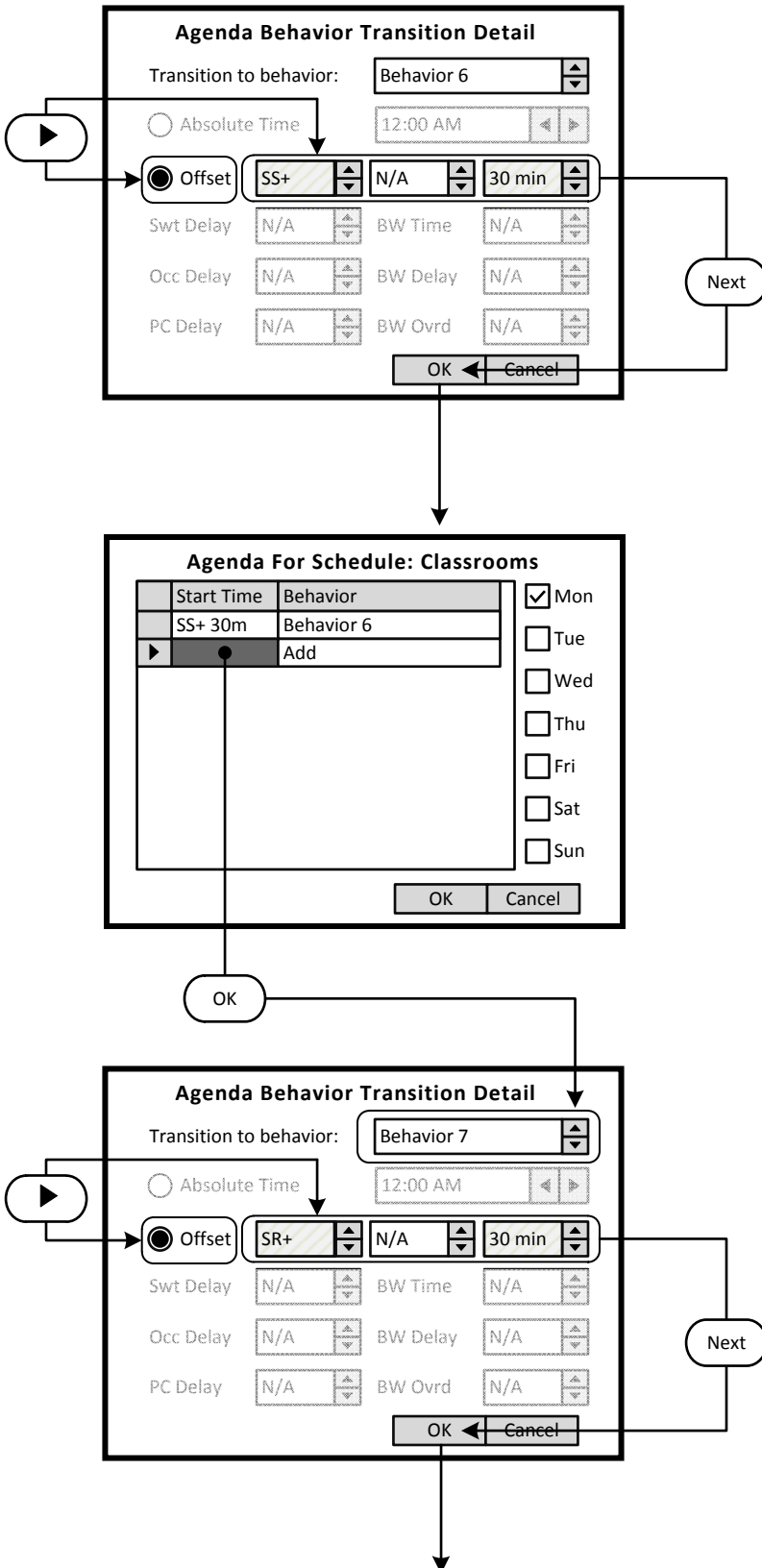

**Step 1.41**

The Exterior Schedule requires the lights to turn On 30 minutes after Sunset.

Use the RIGHT arrow to navigate to the **-SS+-** list. Use the UP and DOWN arrows to select; sunrise plus a time value after (SR+), sunrise minus a time value before (SR-), sunset plus a time value after (SS+), sunset minus a time value before (SS-).

Use the RIGHT arrow to move to the **-Hour-** list box. Use the UP and DOWN arrows to set time offset in hours.

Use the RIGHT arrow to move to the **-Minutes-** list box. Use the UP and DOWN arrows to set time offset in minutes.

Use the NEXT button on the keypad to navigate to the **-OK-** button when finished.

**Step 1.42**

Navigate to the Add line of the list, in this case the second line. Click OK to advance to the Behavior Transition Detail screen.

Understanding the Screen

*This Agenda only applies to Monday, as shown here. A transition to Behavior 6 will occur 30 minutes after Sunset.*

**Step 1.43**

The Exterior Schedule requires the lights to turn Off 30 minutes after Sunrise.

Use the RIGHT arrow to navigate to the **-SS+-** list. Use the UP and DOWN arrows to select; sunrise plus a time value after (SR+), sunrise minus a time value before (SR-), sunset plus a time value after (SS+), sunset minus a time value before (SS-).

Use the RIGHT arrow to move to the **-Hour-** list box. Use the UP and DOWN arrows to set time offset in hours.

Use the RIGHT arrow to move to the **-Minutes-** list box. Use the UP and DOWN arrows to set time offset in minutes.

Use the NEXT button on the keypad to navigate to the **-OK-** button when finished.

- Key
- <Add> On screen button.
- Name- Label of onscreen entry field
- NEXT Button on keypad
- Details Screen Name

**Agenda For Schedule: Classrooms**

Start Time	Behavior
SS+ 30m	Behavior 6
SR+ 30m	Behavior 7
▶	Add

Mon  
 Tue  
 Wed  
 Thu  
 Fri  
 Sat  
 Sun

OK

**Agenda For Schedule: Classrooms**

Start Time	Behavior
SS+ 30m	Behavior 6
SR+ 30m	Behavior 7
▶	Add

Mon  
 Tue  
 Wed  
 Thu  
 Fri  
 Sat  
 Sun

Next

OK

**Agenda For Schedule: Classrooms**

Start Time	Behavior
SS+ 30m	Behavior 6
SR+ 30m	Behavior 7
▶	Add

Mon  
 Tue  
 Wed  
 Thu  
 Fri  
 Sat  
 Sun



**Step 1.44**

Navigate to the -Mon- check box by pressing NEXT.

Understanding the Screen

This Agenda only applies to Monday, as shown here.  
A transition to Behavior 6 will occur 30 minutes after Sunset.

**Step 1.45**

Navigate to the -Tue- check box by pressing NEXT.

Press OK to check the box.

Repeat these steps to fill check all boxes.

**Step 1.46**

Navigate to the -OK- onscreen button by pressing NEXT.

Press OK to save settings and return to the Schedules screen.

Understanding the Screen

This Agenda applies to Monday through Sunday.  
A transition to Behavior 6 will occur 30 minutes after Sunset.  
A transition to Behavior 7 will occur 30 minutes after Sunrise.

- Key
- <Add> On screen button.
- Name- Label of onscreen entry field
- NEXT Button on keypad
- Details Screen Name

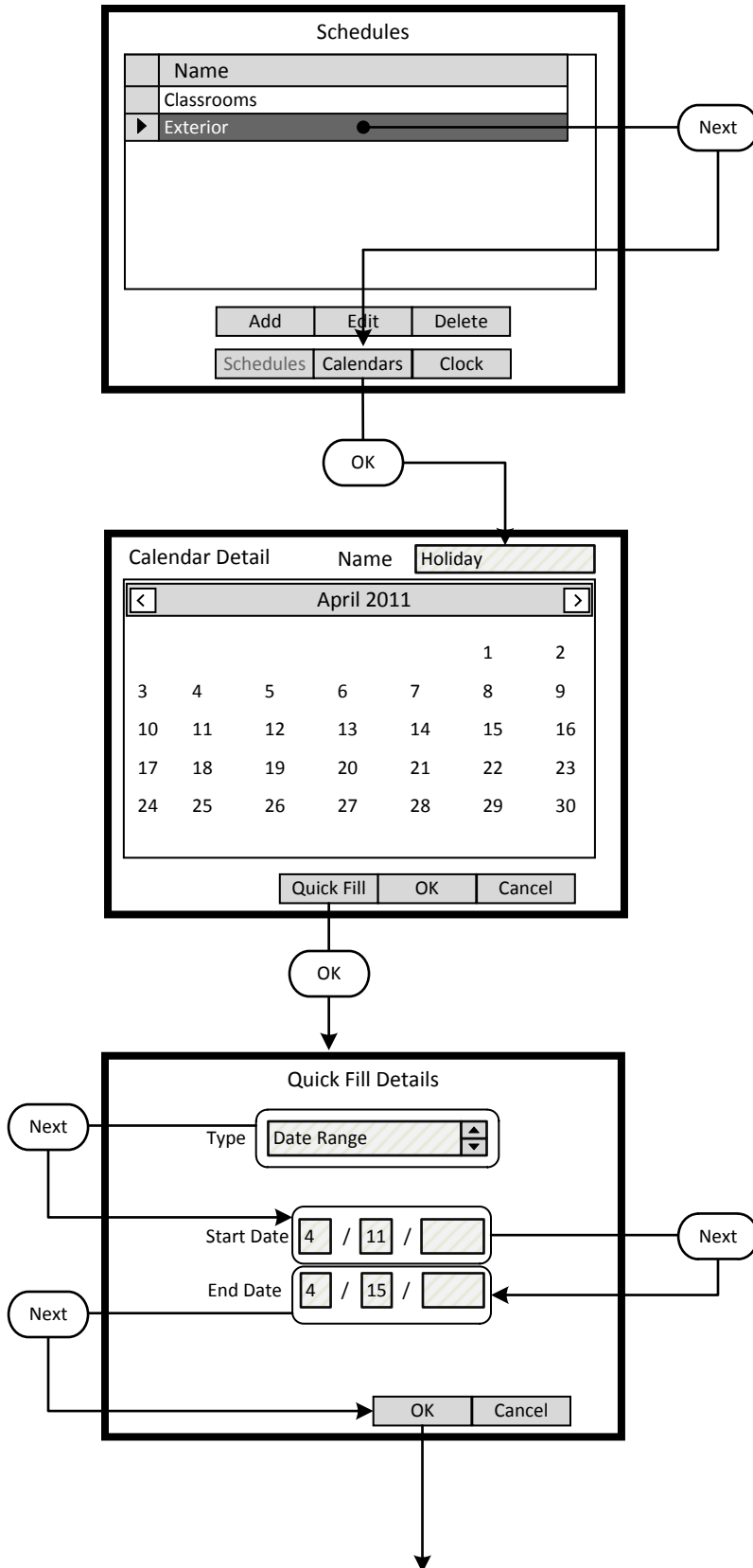

**Step 1.47**

There are now two Schedules available in the system for two different uses and patterns of behavior. To add an Exceptions Calendar to the schedule, navigate to the <Calendars> button and press OK.

To navigate to the Home screen press the HOME button.

Other Options

To modify an existing Schedule, highlight the appropriate Schedule on the list. Navigate to <Edit> and press OK, to initiate the modification of the selected Schedule.

To delete an existing Schedule, highlight the appropriate Schedule on the list. Navigate to <Delete> and press OK, to erase the selected Schedule.

To adjust the system clock, navigate to <Clock> and press OK.

**Step 1.48**

The Exception Calendar can be custom named. This Calendar is to be named -Holiday- and will include April 11 through April 15. A specific pattern of behavior will run on these dates.

To add a range of dates to the Exceptions Calendar, navigate to the <Quick Fill> button and press OK.

Understanding the Screen

This Exception Calendar has no highlighted dates.

To view dates in May, navigate to <>> (right) by pressing the NEXT button. Press OK to select.

To view dates in March, navigate to <<< (left) by pressing the NEXT button. Press OK to select.

To select a specific date on the Calendar, press the NEXT button to move into the date fields. Use the arrow buttons to move to the desired date. Press OK to select.

**Step 1.49**

The selected method of date entry is -Date Range-, the other mode is -Relative Date-. Navigate to and enter the -Start Date-. Fields are provided for month, day, and year. A specific pattern of behavior will run on these dates.

To accept changes navigate to the <OK> button and press OK.

Understanding the Screen

This Exception Calendar will include the dates between April 11 and April 15. Since the year field has been left blank, these dates will apply each year moving forward. The dates will be highlighted on the calendar named -Holiday-.

To abandon changes, navigate to the <Cancel> button and press OK.

To erase entries in a field use the CLEAR button on the keypad.

- Key
- <Add> On screen button.
- Name- Label of onscreen entry field
- NEXT Button on keypad
- Details Screen Name

Calendar Detail      Name:

< April 2011 >

					1	2
3	4	5	6	7	8	9
10	<b>11</b>	<b>12</b>	<b>13</b>	<b>14</b>	<b>15</b>	16
17	18	19	20	21	22	23
24	25	26	27	28	29	30

Quick Fill    OK    Cancel

OK

Schedules

Name	
▶ Classrooms	
Exterior	

Add    Edit ●    Delete

Schedules    Calendars    Clock

Next

Schedule Details      Name:

Date Range Effective:

Mon	MTWTF--
Tue	MTWTF--
Wed	MTWTF--
Thu	MTWTF--
Fri	MTWTF--
Sat	-----SS
Sun	-----SS

Calendars	
▶ Add/Del...	

Areas	
▶ Add/Del...	

Save ●    Cancel

Next

Next

**Step 1.50**

The Exception Calendar named Holiday has highlighted dates from April 11 through April 15. No behavior patterns have been specified, this is done in the Schedule Detail screen. To add additional range of dates to the Exceptions Calendar, navigate to the <Quick Fill> button and press OK.

**Step 1.51**

Once the dates have been added to the Exceptions Calendar, the Calendar can be added to a Schedule. Select the Schedule from the list of two Schedules available in the system. To add an Exceptions Calendar to the schedule, navigate to the <Edit> button and press OK.

**Step 1.52**

To add an Exception Calendar to the Schedule, press the NEXT button on the navigation keypad to advance to the -Add/Del- field. Press OK to select.

Key  
 <Add> On screen button.  
 -Name- Label of on screen entry field  
 NEXT Button on keypad  
 Details Screen Name

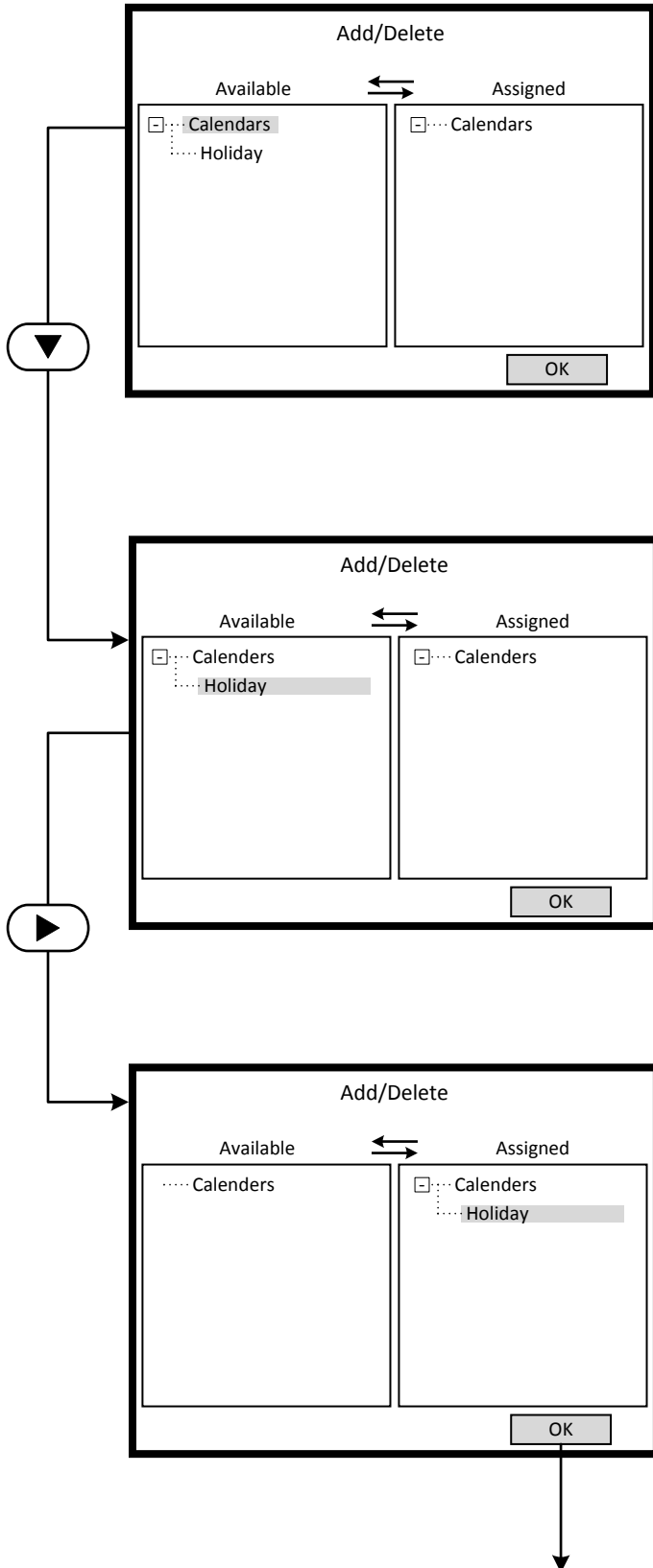

**Step 1.53**

The Exception Calendar named Holiday can be viewed on the list of Available Calendars. Each Exception Calendar that is created appears on the list. Multiple Exception Calendars can be added to a schedule. Exception Calendars can be Assigned Schedules.

The desired Exception Calendar must be moved from the Available list, on the left side of the screen, to the Assigned list on the right.

**Step 1.54**

Use the DOWN arrow to highlight the desired Exceptions Calendar.

**Step 1.55**

Use the RIGHT arrow to move the highlighted Exceptions Calendar to the Assigned List. Reversing the procedure will un-assign the Calendar.



- Key
- <Add> On screen button.
- Name- Label of onscreen entry field
- NEXT Button on keypad
- Details Screen Name

**Schedule Details**      Name

Date Range Effective

Mon	<input type="button" value="MTWTF--"/>	<div style="border-bottom: 1px solid black; padding: 2px;">Calendars</div> <div style="border-bottom: 1px solid black; padding: 2px;">▶ Holiday</div> <div style="border-bottom: 1px solid black; padding: 2px;">Add/Del...</div> <div style="padding: 2px;"> </div> <div style="border-bottom: 1px solid black; padding: 2px;">Areas</div> <div style="border-bottom: 1px solid black; padding: 2px;">▶ Add/Del..</div> <div style="padding: 2px;"> </div>
Tue	<input type="button" value="MTWTF--"/>	
Wed	<input type="button" value="MTWTF--"/>	
Thu	<input type="button" value="MTWTF--"/>	
Fri	<input type="button" value="MTWTF--"/>	
Sat	<input type="button" value="- - - - - SS"/>	
Sun	<input type="button" value="- - - - - SS"/>	

**Agenda For Calendar: Holiday**

	Start Time	Behavior
▶		Add

**Step 1.52**

The Holiday Exception Calendar is now listed as assigned to the Schedule. Press the OK button on the navigation keypad to create or edit the **-Holiday-** Agenda.

**Step 1.44**

Navigate to the **-Mon-** check box by pressing NEXT.

Understanding the Screen

*This Agenda only applies to Monday, as shown here.  
A transition to Behavior 6 will occur 30 minutes after Sunset.*

- Key
- <Add> On screen button.
- Name- Label of onscreen entry field
- NEXT Button on keypad
- Details Screen Name

**Agenda Behavior Transition Detail**

Transition to behavior: Behavior 1

Absolute Time 12:00 PM

Offset N/A N/A N/A

SwT Delay N/A BW Time N/A

Occ Delay N/A BW Delay N/A

PC Delay N/A BW OvrD N/A

OK Cancel

**Step 1.29**

The Behavior Transition Detail screen is entered at the Behavior selection box. Use the UP or DOWN arrows to choose the desired Behavior. Consultate the Behavior chart in the Manual for descriptions. For this example change to Behavior 5.

Understanding the Screen

<Absolute Time> setting for a specific time of the day to trigger a Behavior Transition.

**Agenda Behavior Transition Detail**

Transition to behavior: Behavior 5

Absolute Time 11:01 PM

Offset N/A N/A N/A

SwT Delay N/A BW Time N/A

Occ Delay 1 BW Delay N/A

PC Delay N/A BW OvrD N/A

OK Cancel

**Step 1.30**

Use a combination of the UP and DOWN arrows as well as the NEXT button to change the time to 11:01 PM. When complete, use the NEXT button to navigate to the -Occ Delay- field. Adjust this setting to 1 minute.

OK

**Agenda For Calendar: Holiday**

	Start Time	Behavior
	11:01 PM	Behavior 5
▶		Add

OK Cancel

**Step 1.44**

Navigate to the -Mon- check box by pressing NEXT.

Understanding the Screen

This Agenda only applies to Monday, as shown here.  
A transition to Behavior 6 will occur 30 minutes after Sunset.

- Key
- <Add> On screen button.
- Name- Label of onscreen entry field
- NEXT Button on keypad
- Details Screen Name

**Schedule Details**      Name

Date Range Effective

Mon	<input type="button" value="MTWTF--"/>	<div style="border: 1px solid black; padding: 2px;"> <p><b>Calendars</b></p> <p><input type="button" value="▶ Holiday"/></p> <p><input type="button" value="Add/Del..."/></p> </div> <div style="border: 1px solid black; padding: 2px; margin-top: 5px;"> <p><b>Areas</b></p> <p><input type="button" value="▶ Add/Del..."/></p> </div>
Tue	<input type="button" value="MTWTF--"/>	
Wed	<input type="button" value="MTWTF--"/>	
Thu	<input type="button" value="MTWTF--"/>	
Fri	<input type="button" value="MTWTF--"/>	
Sat	<input type="button" value="- - - - - SS"/>	
Sun	<input type="button" value="- - - - - SS"/>	

OK

Schedules

	Name
▶	Classrooms
	Exterior

Home

Project: TEST

**Step 1.52**

The Holiday Exception Calendar is now listed as assigned to the Schedule. Press the OK button on the navigation keypad to create or edit the **-Holiday-** Agenda.

**Step 1.51**

Once the dates have been added to the Exceptions Calendar, the Calendar can be added to a Schedule. Select the Schedule from the list of two Schedules available in the system. To add an Exceptions Calendar to the schedule, navigate to the **<Edit>** button and press OK.

**Programming Exercise: Classroom**

-Name- Label of on onscreen entry field  
 NEXT Button on keypad  
 Details Screen Name

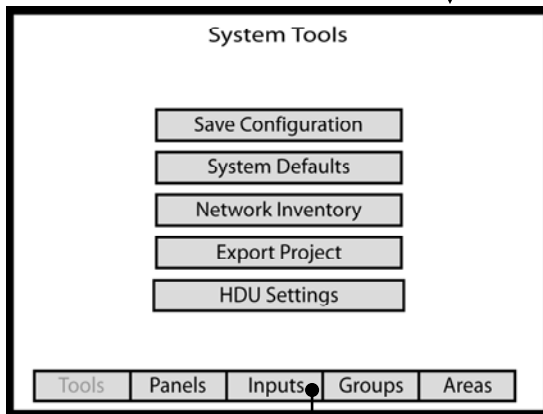

OK

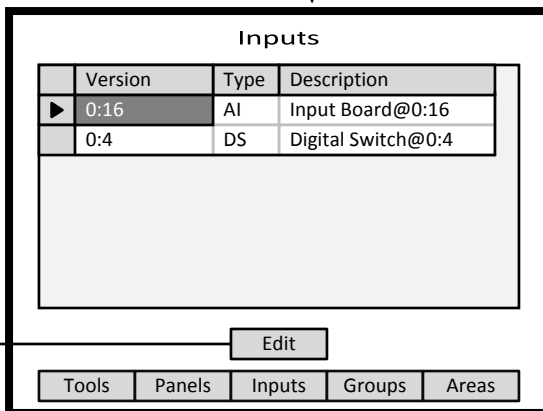

OK

**Step 2: Configure Devices**

The GreenMAX can be configured to handle a wide variety of input devices. These devices operate at +24vdc and are wired to an input terminal on the Low Voltage (AI) board. Each terminal port must be configured to match the device and its expected functionality.

The following Low Voltage input devices can be connected to the system:

- Occupancy sensors.
- Photocells.
- Switches.
- Contact closures.

**Step 2.1**

The configuration steps of the Low Voltage Input Card is performed in the <Config> section of the HDU software.

Understanding the Screen

There are three sections of the HDU software. The other two sections under the buttons are:

- <Monitor> - Used to check the system time, relay status
- <Control> - Access Scheduling

**Step 2.2**

Use a combination of the UP and DOWN arrows as well as the NEXT button to navigate to the <Inputs> onscreen button. Press OK to select.

**Step 2.3**

The Network Inventory will provide a listing of all system Input devices. This includes both Low Voltage Input Boards (AI) and Digital switches.

Understanding the Screen

There are two Input Devices in this system.

There is a 16 input AI board at address ID 16.

There is a 4 button Digital Switch at address ID 4.

Description of the onscreen buttons:

- <Edit> selecting this onscreen button will allow editing of the highlighted device in the list.
- <Tools> use to navigate to the System Tools screen.
- <Panels> use to navigate to the Relay Panel Detail Screen
- <Groups> use to navigate to the Group building screen
- <Areas> use to navigate to the Areas configuration screen

- Key
- <Add> On screen button.
- Name- Label of onscreen entry field
- NEXT Button on keypad
- Details Screen Name

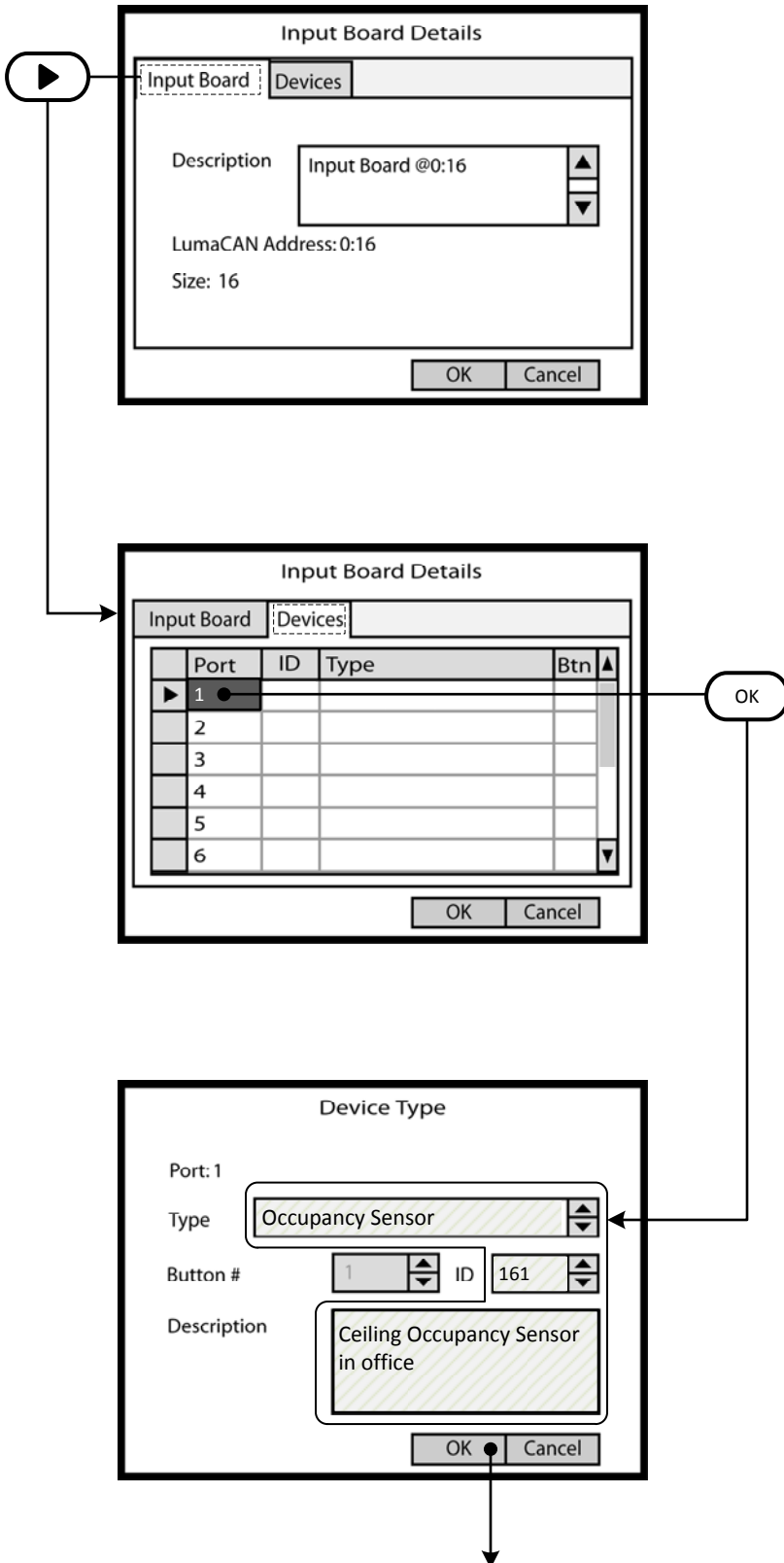

**Step 2.4**

The **Input Board Details** screen displays the number of inputs, the LumaCan address ID and the **-Description-** field. Enter job specific description in this field. Once the correct information is entered, use the RIGHT arrow to move to the **-Devices-** tab at the top of the screen.

Understanding the Screen

The other onscreen buttons are:  
 <OK> - Used to accept the entries  
 <Cancel> - Used to discard entries

**Step 2.5**

The **-Devices-** tab reveals a list of the Input Ports on the AI Board being configured. Ports are numbered sequentially in quantities of 8 or 16. No data entry can be made on this screen. Highlight the Input Port number and press OK to enter the editing screen.

Use the UP or DOWN arrows on the keypad to navigate up or down the list. The scroll bar to the right indicates position on the list.

If the wrong device type appears on the list, highlight the Input Port number and press CLEAR on the keypad.

Understanding the Screen

No devices have been configured for this AI board.  
 The onscreen buttons are:  
 <OK> - Used to accept the entries  
 <Cancel> - Used to discard entries

**Step 2.6**

The Device Type screen is used to select the type of device that is wired to the input port. Use the UP and DOWN arrows on the keypad to display the desired device. The Description field should be used to document the location of the device.

Understanding the Screen

The **-Button #-** is available for display purposes only and does not have any configuration value.

The **-ID-** is available for display purposes only and does not have any configuration value. It can be used to match the numbering on project drawings. Maximum value is 1000.

- Key
- <Add> On screen button.
- Name- Label of onscreen entry field
- NEXT Button on keypad
- Details Screen Name

**Input Board Details**

Input Board	Devices			
Port	ID	Type	Btn ▲	
1	161	Occupancy Sensor		
2	162	Closed Loop Photocell		
3	163	Trigger Photocell		
4	164	Occupancy Sensor		
5	232	Occupancy Sensor		
6	232	Open Loop Photocell		

OK ● Cancel

**Step 2.8**

The fully populated **Input Board Details** screen will look as shown here. The Input Ports can be configured in any order as necessary.

Understanding the Screen

The ID numbers are for information purposes. They can be any number that makes sense to the user. The system only stores these numbers and does not use them for any function other than identification. The 'Btn' column will be populated with switch button numbers if Low Voltage Switches are configured at the Port location.

- The other onscreen buttons are:
- <OK> - Used to accept the entries
- <Cancel> - Used to discard entries

**Inputs**

Version	Type	Description
0:16	AI	Input Board@0:16
0:4	DS	Digital Switch@0:4

Edit

Tools Panels Inputs Groups Areas

Next

**Inputs**

Version	Type	Description
0:16	AI	Input Board@0:16
0:4	DS	Digital Switch@0:4

Edit ●

Tools Panels Inputs Groups Areas

OK

**Step 2.9**

The **Inputs** listing shows a Digital Switch at LumaCan ID 4. This is a 4 button Digital Switch to be used for Dimming control. Highlight the device and move the indicator to the appropriate device line. Use the UP and DOWN arrows to move about the list. Use NEXT to navigate to the <Edit> button.

- Key
- <Add> On screen button.
- Name- Label of onscreen entry field
- NEXT Button on keypad
- Details Screen Name

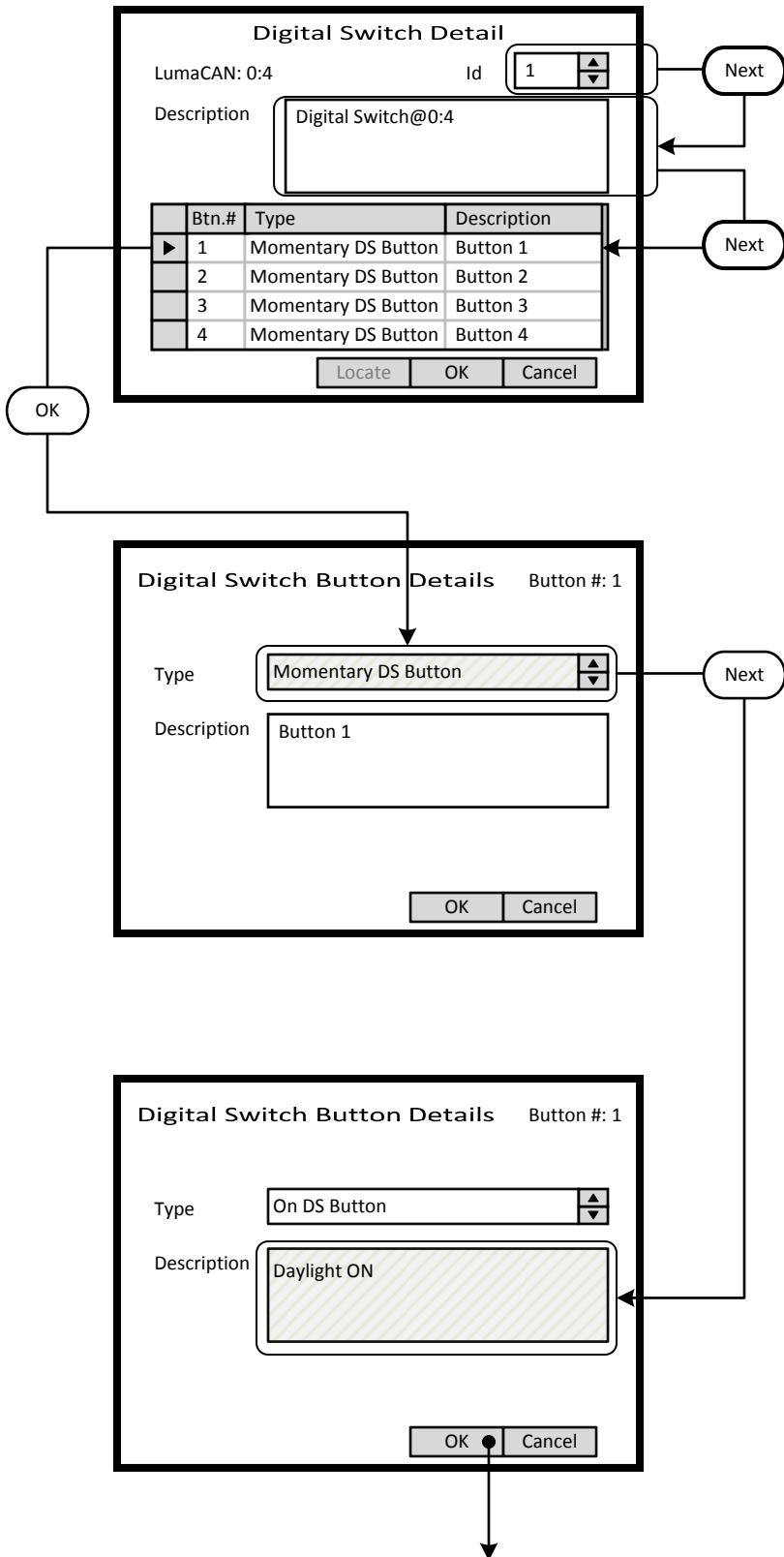

**Step 2.10**

The **Digital Switch Detail** screen provides an ID setting for informational purposes and a description field. These fields fill the list on the previous screen. Button function must be configured. Highlight the Button number and press OK to enter the editing screen.

Use the UP or DOWN arrows on the keypad to navigate up or down the list.

**Step 2.11**

The **Digital Switch Button Details** screen is used to configure the individual button function and to name the button. Use the UP and DOWN arrows on the keypad to display the desired button function.

The Description field should be used to document the function of the individual buttons. This field is for user reference only.

Understanding the Screen

- The type options are:
- Momentary DS Button
  - On DS Button
  - Bright DS Button
  - Dim DS Button
  - Off DS Button

- Key
- <Add> On screen button.
- Name- Label of onscreen entry field
- NEXT Button on keypad
- Details Screen Name

**Digital Switch Detail**

LumaCAN: 0:4                      Id

Description

Btn.#	Type	Description
▶ 1	On DS Button	Daylighting On
2	Bright DS Button	Button 2
3	Dim DS Button	Button 3
4	Off DS Button	Button 4

OK

**Inputs**

	Version	Type	Description
	0:16	AI	Input Board@0:16
▶	0:4	DS	Dimming Zone 1

**Step 2.12**

This illustration shows the recommended configuration for a Digital Switch used for dimming control application. The button Type fields should match those shown. Each field should be adjusted individually. Button descriptions are entered on the Button Detail Screen shown previous.

Use the UP or DOWN arrows on the keypad to navigate up or down the list.

Use NEXT and BACK to navigate between sections on the screen.

Understanding the Screen

The ID number are for information purposes and can be used to match assigned project switch numbers.

**Step 2.13**

The Inputs list has a Digital Switch at ID 4 and is described as Dimming Zone 1.

Use the UP and DOWN arrows to move about the list. Use NEXT to navigate to the <Areas> button.



<b>Relay Details</b>		<b>Description</b>	
Number: 1		Relay 01	
Channel: 1			
Type: 1TB			
<input type="checkbox"/> Blink Warn Enabled		<input type="checkbox"/> Pulsed Relay	
BW Time: 0.5 Sec.		<input type="checkbox"/> Normally Open	
BW Delay: 1 Min.		<input type="checkbox"/> On	Sec
BW Ovrld: 4 Min.		<input type="checkbox"/> Off	Sec
		Emergency	Ignore
Prev	Next	Test	OK Cancel

Btn.#	Type	Description
▶ 1	On DS Button	Button 1
2	Bright DS Button	Button 2
3	Dim DS Button	Button 3
4	Off DS Button	Button 4

Locate OK Cancel

OK

Inputs			
Version	Type	Description	
0:16	AI	Input Board@0:16	
▶ 0:4	DS	Dimming Zone 1	
Edit			
Tools	Panels	Inputs	Groups Areas



- Key
- <Add> On screen button.
- Name- Label of onscreen entry field
- NEXT Button on keypad
- Details Screen Name

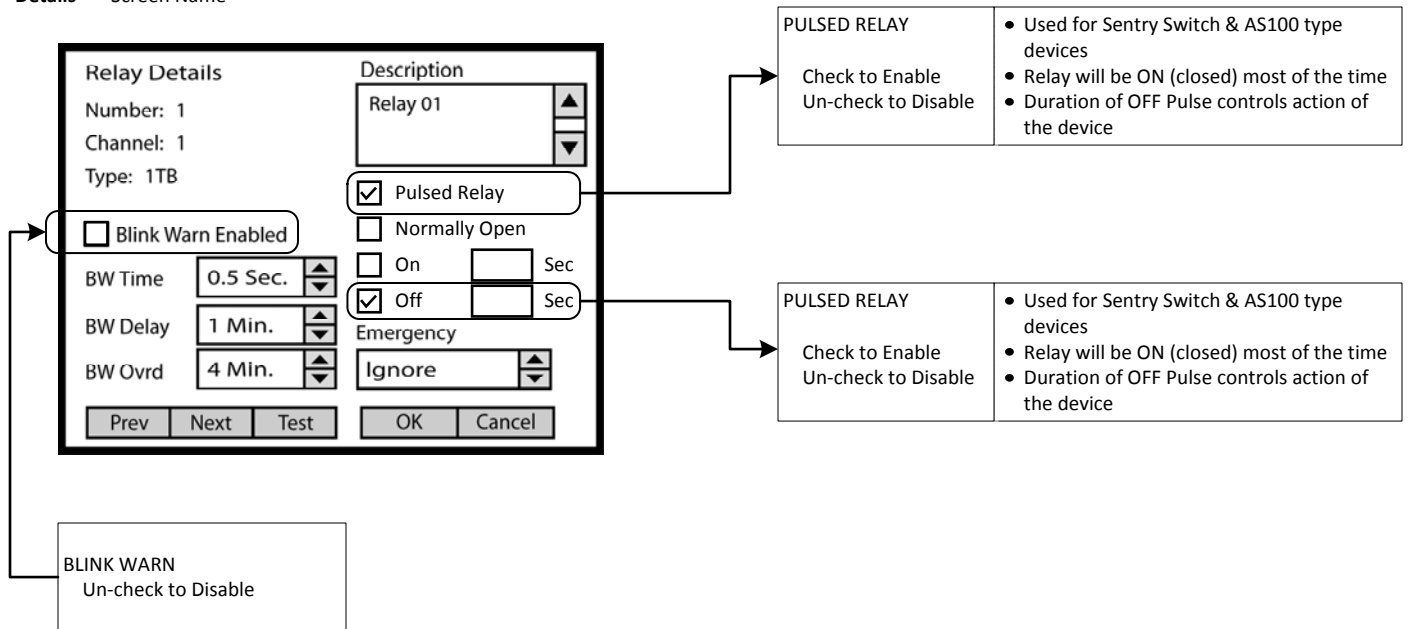

**Step 2.11**

This illustration shows the recommended configuration for a Digital Switch used for dimming control application. The button Type fields should match those shown. Each field should be adjusted individually. Button descriptions are entered on the Button Detail Screen shown previous.

Use the UP or DOWN arrows on the keypad to navigate up or down the list.

Use NEXT and BACK to navigate between sections on the screen.

Understanding the Screen

The ID number are for information purposes and can be used to match assigned project switch numbers.