



Cabling Architectures for Smart Buildings

Smart building technology plays an increasingly important role in enterprise networks. While the global pandemic has been a disruptive force for office environments, many businesses are continuing to make changes to workspaces to incorporate smart building initiatives — not only as a short-term response to the pandemic to keep people safe and comfortable, but also as a long-term strategy to improve workplace environments and productivity.

In fact, more than half of organizations plan to increase their investment in smart building technology and energy efficiency in 2021, according to Johnson Controls' October 2020 Energy Efficiency Indicator survey.

In this issue, as part of our ongoing look at networks for smart buildings, we will outline the two main cabling approaches for connecting and powering smart devices: **fixture centric and node centric**.

FIXTURE CENTRIC

In a fixture centric design, all devices use home run cabling from the device back to the telecommunications room (TR). This is more common for remote devices such as security cameras. It centralizes all the active equipment in the TR, which can simplify maintenance and make it easier to supply back-up power to critical systems.

The downside to a fixture centric design: it is less flexible when performing moves, adds, and changes, as reconfiguring home run cabling is typically time-consuming and expensive. These links are most often installed above drop ceilings or inside walls, and accessibility can become an issue. Also, in some cases the home runs can be very long and changes may involve reworking the entire link all the way back to the TR. For example, if the security camera needs to be moved five feet closer, there might not be an issue, but if it moves five feet farther out, there might not be enough cable and the entire link will need to be reworked.

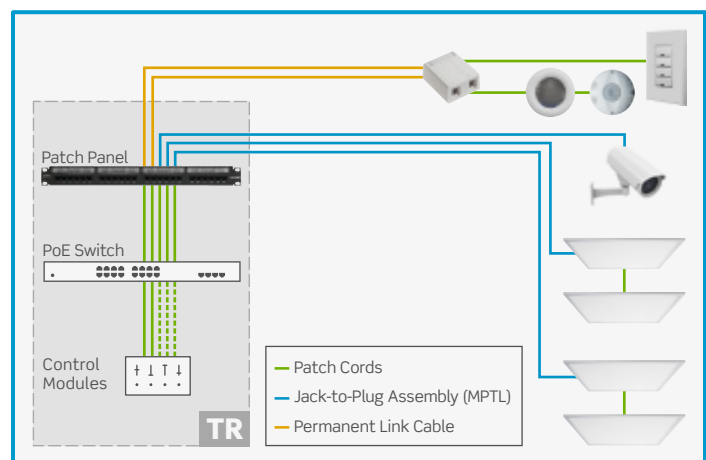

NODE CENTRIC

Also known as zone cabling, a node centric architecture inserts a consolidation point (CP) into the design. Instead of a cable running directly from the TR to the end device, the permanent link stops at the CP. This adds flexibility, so if devices need to be moved in a room, the only change happens to the connecting patch cord, while the CP and permanent link stay in place.

Node centric designs also provide the opportunity to incorporate fiber optic cabling into the network for higher bandwidth applications or extended reach requirements beyond 100 meters. Fiber can run to the CP, where a media converter can be used to convert to copper based Ethernet to connect to the end device.

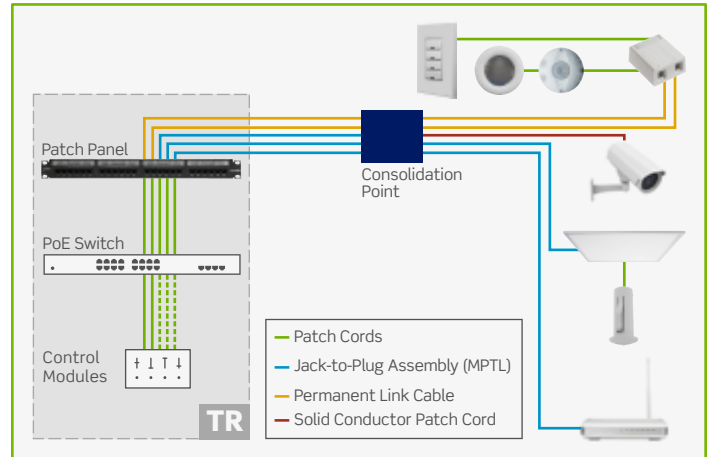

The most common cabling installation is a node centric architecture with a passive CP — where all active equipment is located in the TR. There are some scenarios where installations use an active CP and the introduction point for power is at the CP. This could be in the form of a PoE switch inside the CP. The active CP design often becomes a choice when newer switches already exist in the TR but are not PoE enabled, or a high data rate is required between the TR and the CP, resulting in fiber as the media for this link. In this scenario a media conversion occurs in the CP to deliver power and data to end devices. One potential downside to an active CP: there is the possibility for unwanted noise from added cooling fans, which could be an issue when located directly above workspaces.

Daisy Chaining — As shown in both fixture centric and node centric schematics, daisy chain implementations can be made in both types of installations. Daisy chaining — where numerous end devices are connected in a series via patch cords — is a common scenario in the electrical world but has not historically been used much in the networking world. However, more smart devices are now designed to be daisy chained, especially for PoE light fixtures that are relatively close together and require low data rates.

There is no simple answer to which design is best for networking smart buildings and IoT devices; it ultimately comes down to the priorities of the network and the application requirements. When it comes to cabling, there are some cost differences between the options. While costs can vary based on the length of cable runs and other variables, a node centric design will typically cost 10% less than a fixture centric design, as it uses less cable and fewer home runs. Node centric designs may see increased costs from more active equipment and lower switch port utilization, however due to reduced cabling costs the overall implementation will be less expensive.

Learn more about infrastructure for smart buildings, including telecommunications room rack and space requirements, in the Leviton on-demand webinar [Smart Buildings: What Infrastructure Do You Need?](#)